

# MaxiMet<sup>®</sup>

## Compact Weather Station

### User Manual



**Document Number: 1957-PS-021 Iss 12 applies to units**  
with Serial Numbers 24260001 onwards and firmware 2.28.09 (GMX552 Only) or 2.26.04 (all other MaxiMet)

### Contents

<b>1. Welcome to the MaxiMet User Manual</b>	<b>4</b>
1.1. Overview of Content	4
1.2. Description of Icons	4
<b>2. Product Overview and Functions</b>	<b>6</b>
2.1. MaxiMet part numbers and features	7
2.2. Summary of MaxiMet and Derived Parameters	8
2.3. Wind Speed and Direction Sensor (GMX200, 240, 500, 501, 550, 551, 552, 600, 603)	10
2.4. Solar Radiation Shield (GMX300, 301, 400, 500, 501, 550, 551, 552, 600, 603)	11
2.5. Barometric Pressure (GMX300, 301, 400, 500, 501, 550, 551, 552, 600, 603)	11
2.6. Temperature, Relative Humidity and Dewpoint	11
2.7. Rain/Precipitation (GMX603 and GMX550/551 with TruMet PW100)	11
2.8. Rain/Precipitation (GMX240, GMX400, GMX550/551, Optional Part 1957-PK-073 & GMX600)	11
2.9. Rain/Precipitation (GMX550 and GMX551)	12
2.10. Compass	12
2.11. Compass Declination	12
2.12. Solar (GMX301, GMX501, GMX551)	12
2.13. GPS Option (GMX200, GMX240, GMX500, GMX550, GMX551, GMX552, GMX600, GMX603)	13
2.14. Inclinator (All MaxiMet Models, diagram illustrates a GMX550)	13
2.15. Heating Function Option (GMX600, 551, 550, 501, 500, 603)	13
2.16. Black Globe Temperature (GMX552)	14
2.17. Wet Bulb Temperature (GMX552 with Wet Bulb Sensor 5437-PK-046 or 5437-PK-047)	14
2.18. Derived Wet Bulb Globe Temperature (GMX552)	14
2.19. Wet Bulb Globe Temperature (GMX552 with Wet Bulb Sensor 5437-PK-046 or 5437-PK-047)	14
<b>3. Pre-Installation</b>	<b>15</b>
3.1. Equipment supplied	15
3.2. Optional Extras/Spares	15
3.3. Right to change and revise	16
3.4. Packaging	16
3.5. Specification	16
3.6. Downloadable Software	16
3.7. Setup Requirements	17
3.8. Software	17
3.9. Bench System Test	17
<b>4. Installation Requirements</b>	<b>18</b>
4.1. General Installation Guidelines	18
4.2. Guidelines	18
4.3. Wind	19
4.4. Compass	19
4.5. GPS	20
4.6. Solar	20
4.7. Tilt	20
4.8. Rain	21

### Contents

4.9. Wet Bulb Temperature Sensor (Optional with GMX552)	21
4.10. Black Globe Temperature and Wet Bulb Globe Temperature (GMX552)	25
4.11. General Alignment	26
4.12. Mounting Tube e.g. Gill Part 1405-30-056	27
4.13. Mounting Bracket e.g. Gill Part 1771-PK-115	27
4.14. Dimensions (in mm)	28
<b>5. Connector and Pin allocation</b>	<b>29</b>
5.1. View of the MaxiMet Connector looking down at the Cable Side	34
5.2. 9-Way Connector and Cable Connections	34
5.3. MaxiMet Units	35
5.4. Heating power supply	35
5.5. Connecting to a PC using RS232 (Default Setting)	36
5.6. Connecting to a PC using RS422 (Not a default setting)	37
5.7. Using RS485 (not a default setting)	38
5.8. Using SDI-12 (2 wire network, not a default setting)	39
5.9. Using the Kalyx Rain Gauge GMX550/GMX551 (or user supplied Rain Gauge)	39
5.10. Using the MaxiMet GMX551 with Optional Gill Solid State Rain Gauge	42
5.11. Using the MaxiMet GMX552 with Optional Gill Wet Bulb Temperature Sensor	43
5.12. GMX 603 Connector	44
<b>Appendix A. Technical Specification</b>	<b>45</b>
<b>Appendix B. Default Configurations</b>	<b>53</b>
<b>Appendix C. Connector and Cable Assembly</b>	<b>85</b>
<b>Appendix D. Configuring MaxiMet with MetSet</b>	<b>91</b>
<b>Appendix E. Configuring MaxiMet for SDI-12</b>	<b>108</b>
<b>Appendix F. Configuring MaxiMet for Modbus</b>	<b>115</b>
<b>Appendix G. Configuring MaxiMet for NMEA 0183 Output</b>	<b>136</b>
<b>Appendix H. Safe Mode</b>	<b>140</b>
<b>Appendix I. Using a Terminal Program to run MaxiMet Tilt function</b>	<b>146</b>
<b>Appendix J. Using a Terminal Program to set MaxiMet Date and Time</b>	<b>148</b>
<b>Appendix K. Using a Terminal Program to Apply Temperature &amp; Relative Humidity Correction</b>	<b>149</b>
<b>Appendix L. Using Gill MetView Software to View the MaxiMet Data String</b>	<b>152</b>
<b>Appendix M. Maintenance &amp; fault-finding</b>	<b>166</b>
<b>Appendix N. MaxiMet Output Parameters selectable using MetSet Software</b>	<b>180</b>
<b>Appendix O. Guarantee, FCC &amp; EMC</b>	<b>195</b>

### 1. Welcome to the MaxiMet User Manual

#### About this manual

This manual provides the information needed to get the best results from MaxiMet. The most recent version of this manual is available at [gillinstruments.com](http://gillinstruments.com). Please read this manual before setting up and installing MaxiMet.





#### 1.1. Overview of Content

The manual is split into 5 chapters. Each chapter represents an activity in the use of the product. Additional detailed information is contained in the Appendices at the end of the manual.

- Chapter 1 Explains how the manual is set out
- Chapter 2 Provides product overview and functionality
- Chapter 3 Provides the information needed to pre-install the product
- Chapter 4 Explains installation requirements for the product
- Chapter 5 Provides the information needed to install the product

#### 1.2. Description of Icons

The following icons are used in this manual.

Icon	Description
	A note that is important and that should be observed
	Information or a recommendation to ensure best results
	The start of a set of instructions
	<b>Warning: Hot Surface.</b> When heating is activated, the heated ultrasonic transducers will get very hot and should not be touched.



Before MaxiMet is used for the first time it is essential to read and understand this manual. Please keep the manual safe for future reference.



Care should be taken with MaxiMet at all times. The product should be transported to site in the box, and only removed when ready to install.



During installation MaxiMet should be supported and care should be taken not to drop the product



Care should be taken when wiring the MaxiMet to power and communications.



Maintenance should be limited to the procedures described in this manual. Additional maintenance or cleaning may damage the sensors.



No attempt should be made to open or repair any of the parts of the product. Any attempt to dismantle any part of the product will invalidate the warranty provided by Gill Instruments.



**Warning: Hot Surface.** When heating is activated, the heated ultrasonic transducers will get very hot and should not be touched.

Document Version	Release Date	Key Changes
Issue 9	February 2024	New Manual Template and heated transducer updates
Issue 10	July 2024	Minor measurement output additions for firmware release v2.26
Issue 11	October 2025	Format update. Multiple corrections. Addition of GMX552
Issue 12	February 2026	Addition of GMX603

### 2. Product Overview and Functions

The Gill MaxiMet sensor units are very robust with no moving parts. The sensor units of measure, output rate and Communication formats are all user selectable. The MaxiMet can be used in conjunction with a PC, data logger or other device.

Project Code	Model number			Wind Speed		Options		
1957	0	X	X	X	X	X	X	X



MaxiMet	Model Number				Range m/s		Non GPS/GPS/Heated																		
	0	2	0	0	6	0	<table border="1"> <thead> <tr> <th>Non GPS</th> <td>0</td> <td>0</td> <td>0</td> </tr> <tr> <th>GPS</th> <td>1</td> <td>0</td> <td>0</td> </tr> <tr> <th>Non-GPS (HTD)</th> <td>0</td> <td>0</td> <td>1</td> </tr> <tr> <th>GPS (HTD)</th> <td>1</td> <td>0</td> <td>1</td> </tr> </thead> </table>			Non GPS	0	0	0	GPS	1	0	0	Non-GPS (HTD)	0	0	1	GPS (HTD)	1	0	1
Non GPS	0	0	0																						
GPS	1	0	0																						
Non-GPS (HTD)	0	0	1																						
GPS (HTD)	1	0	1																						
	0	2	4	0																					
	0	3	0	0																					
	0	3	0	1																					
	0	4	0	0																					
	0	5	0	0																					
	0	5	0	1																					
	0	5	5	0																					
	0	5	5	2																					
	0	6	0	0																					
	0	6	0	3																					



**Note:** HTD refers to heated MaxiMets

The MaxiMet combines all the instrument data into a single data string. This may be configured for digital ASCII RS232/RS422/RS485 (2 wire point to point only), digital Modbus RTU/ASCII, NMEA and SDI-12 outputs.

## Compact Weather Station

### 2.1. MaxiMet part numbers and features

GMX Sensor Feature	300	301	400	200	240	500	501	550	551	552	600	603
Wind Speed, Relative												
Wind Direction, Relative												
Compass, Heading												
Temperature, Air												
Humidity, Relative												
Barometric Pressure												
Black Globe Temperature												
Wet Bulb Temperature												
Rain/Precipitation												
Solar Radiation												
Angle of Tilt												
GPS (option)				Opt	Opt	Opt	Opt	Opt	Opt	Opt	Opt	Opt
Heating						Opt	Opt	Opt	Opt		Opt	Opt



For information within the part structure:

1957-0XXX**X**-XX-XXX

**X** – A number greater than 0 identifies the unit to have a Solar Sensor, Black Globe Temperature Sensor, or Precipitation Sensor on the top of the unit.

1957-05**XX**-XX-XXX

**X** - A number greater than 0 identifies the unit to have an external rain gauge input or external Wet Bulb Temperature Sensor input

1957-0XXX-XX-**1**XX

**1** in this position identifies the unit to have GPS fitted

1957-0XXX-XX-XX**1**

**1** in this position identifies that this unit has heated ultrasonic transducers

## Compact Weather Station

### 2.2. Summary of MaxiMet and Derived Parameters

See Appendix N on page 180 for more details.

GMX Derived Parameter	300	301	400	200	240	500	501	550	551	552	600	603
Average Speed and Direction (WMO)												
Corrected Direction & Average Corrected Direction (WMO)												
Gust Direction, Gust Speed (WMO)												
Status (Sensors)												
Wind Status												
Dewpoint, Absolute Humidity												
Pressure at Sea Level, Pressure at Station												
Rain/Precipitation Intensity, Total, Status												
Wind Chill, Heat Index												
Air Density												
Derived Wet Bulb Temperature												
Wet Bulb Globe Temperature												
Solar (sunshine) Hours												

GMX Derived Parameter	300	301	400	200	240	500	501	550	551	552	600	603
Twilight, Sunrise, Solar Noon, Sunset,												
Position of the Sun												
Node Letter, Supply Voltage												
Date & Time												
Corrected Speed				GPS Opt	GPS Opt	GPS Opt	GPS Opt	GPS Opt	GPS Opt	GPS Opt	GPS Opt	GPS Opt
Average Corrected Speed (WMO)				GPS Opt	GPS Opt	GPS Opt	GPS Opt	GPS Opt	GPS Opt	GPS Opt	GPS Opt	GPS Opt
Corrected Gust Speed & Direction				GPS Opt	GPS Opt	GPS Opt	GPS Opt	GPS Opt	GPS Opt	GPS Opt	GPS Opt	GPS Opt
GPS Location (Longitude/latitude)				GPS Opt	GPS Opt	GPS Opt	GPS Opt	GPS Opt	GPS Opt	GPS Opt	GPS Opt	GPS Opt
GPS Heading, Speed & Status				GPS Opt	GPS Opt	GPS Opt	GPS Opt	GPS Opt	GPS Opt	GPS Opt	GPS Opt	GPS Opt

### 2.3. Wind Speed and Direction Sensor (GMX200, 240, 500, 501, 550, 551, 552, 600, 603)

The MaxiMet uses the Gill Ultrasonic WindSonic wind speed and direction sensor. The WindSonic measures the times taken for an ultrasonic pulse of sound to travel from the north (N) transducer to the south (S) transducer and compares it with the time for a pulse to travel from S to N transducer. Likewise, times are compared between west (W) and east (E), and E and W transducer.

If, for example, a north wind is blowing, then the time taken for the pulse to travel from N to S will be faster than from S to N, whereas the W to E and E to W times will be the same. The wind speed and direction can then be calculated from the differences in the times of flight on each axis. This calculation is independent of factors such as temperature.

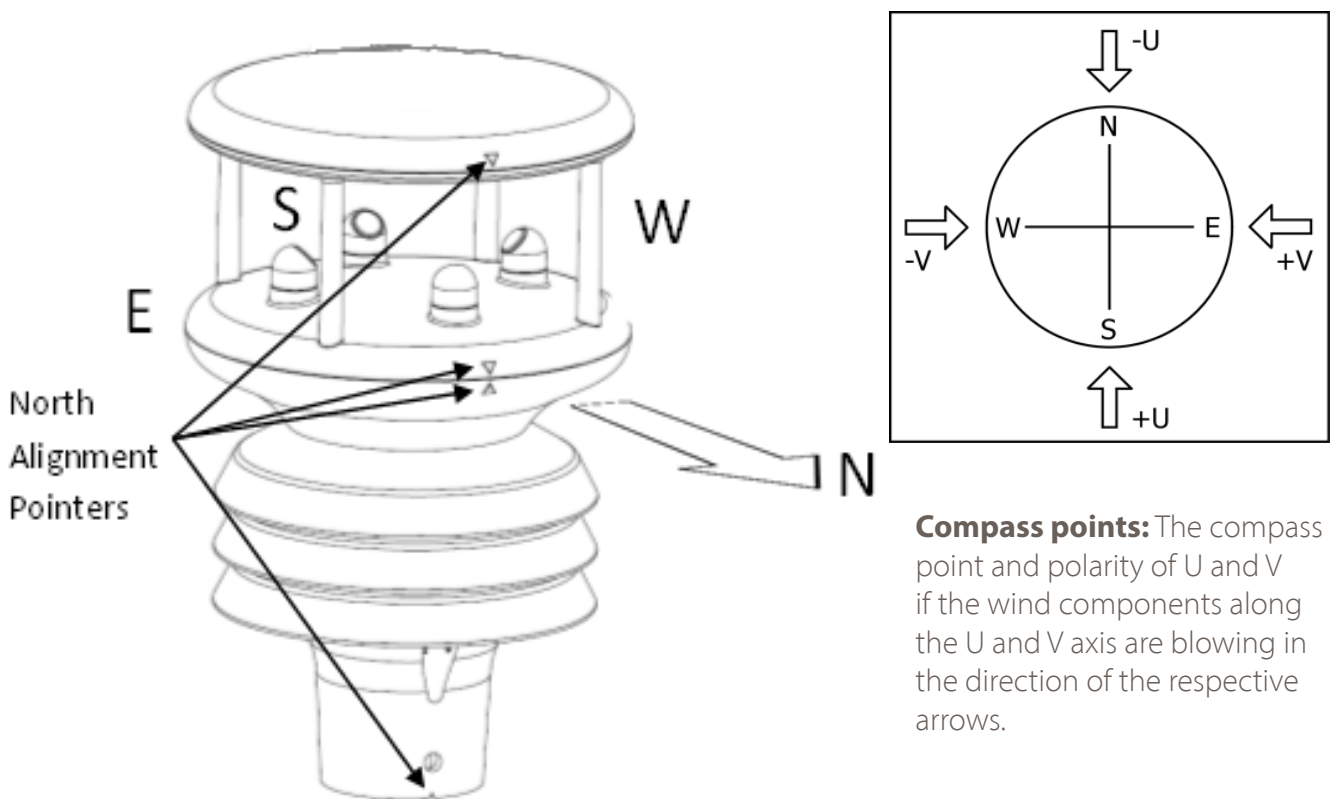

**Compass points:** The compass point and polarity of U and V if the wind components along the U and V axis are blowing in the direction of the respective arrows.

MaxiMet can output the following wind readings depending on use of a Compass or GPS:

- Relative wind – wind speed and/or direction, uncorrected, but relative to the north marker, which may not be facing north.
- Corrected wind – with the aid of the Compass Magnetic North corrected wind direction can be output.
- True wind – wind speed and/or direction information corrected by GPS for any direction misalignment of the north marker and/or for any motion of the station. (E.g. vehicle or vessel).

### 2.4. Solar Radiation Shield (GMX300, 301, 400, 500, 501, 550, 551, 552, 600, 603)

A MetSpec Multi-Plate Solar Radiation Shield is used. The special shield plate geometry, with its double louvre design, provides excellent response time performance of quick ambient temperature changes while still working effectively as a shield to stop larger contaminants such as salt or dirt from reaching the temperature and humidity sensors.

The shield benefits from very robust material choice and extremely high UV protection requiring no maintenance.

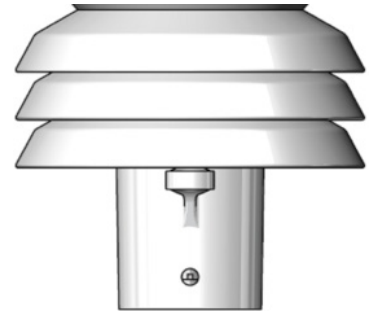

### 2.5. Barometric Pressure (GMX300, 301, 400, 500, 501, 550, 551, 552, 600, 603)

Barometric pressure is provided by a solid-state device fitted onto a board inside a MaxiMet moulding.

### 2.6. Temperature, Relative Humidity and Dewpoint (GMX300, 301, 400, 500, 501, 550, 551, 552, 600, 603)

There are internal solid state sensor circuits contained within the radiation shield that provides digital output signals for Relative Humidity, Temperature and calculated Dewpoint.

### 2.7. Rain/Precipitation (GMX603 and GMX550/551 with TruMet PW100)

Rain accumulation detection is provided using the optical technology of the Gill TruMet PW100. Please refer to the TruMet PW100 manual for details on this accurate rain gauge technology.

These MaxiMet variants increment rain detected in 0.1 mm steps.

### 2.8. Rain/Precipitation (GMX240, GMX400, GMX550/551 with Optional Part 1957-PK-073 and GMX600)

Rain drop detection and a reading of rain level is provided by using an optical infra-red beam sensor. Infra-red beams bounce off the inner optical surface between transmitters and receivers. Depending on rain drop levels the intensity of the beams change and internal digital signal processing allows a measurement of Rain levels to be made.

The MaxiMet Optical rain sensor increments rain detected in 0.080mm/hour steps (default setting) but tip size can be changed.



#### **The default tip size setting for the GMX551 is 0.000mm/hr.**

The GMX551 rain gauge is supplied with a 20 M lead with 9 way and 4-way connectors fitted.



The RG11 Optical sensor provides a General Indication only of rainfall levels for use in situations where low maintenance is required. Use a TruMet PW100 or tipping bucket with a MaxiMet (e.g. GMX550 and GMX551) where reference quality precipitation measurements are required.

### 2.9. Rain/Precipitation (GMX550 and GMX551)

A reading of rain levels is provided by a supplied TruMet PW100 or Kalyx tipping bucket rain gauge. A rain gauge switch contact closure is required to be connected through the 4-way plug-in connector, to register that a tip has occurred.

For details on the preferred TruMet PW100 rain gauge please refer to the TruMet product manual.

The Kalyx tipping bucket provides a tip contact closure for each 0.200mm/hour of rain. The default tip size is 0.000mm/hour for external rain yes/no sensor but this can be adjusted by the user to suit their supplier rain gauge.

For rainfall rates above 120mm/hour and up to 1000mm/hour then contact EML in the UK for a mathematical correction to readings.

The Kalyx rain gauge is supplied wired to a 20 metre long cable which has a 4-way connector fitted to it that plugs into a socket in the moulding of the GMX551.

### 2.10. Compass (GMX200, GMX240, GMX500, GMX501, GMX550, GMX551, GMX552, GMX600, GMX603)

The MaxiMet units contain a 2-axis flux gate compass.

MaxiMet uses the internal compass to electronically sense the horizontal component of the Earth's magnetic field. Information from the compass can be used to correct the Wind direction data for when the MaxiMet is not aligned to North. The output of the wind direction is relative to magnetic North. The MaxiMet compass is calibrated at Gill Instruments before the unit is delivered.

Prior to installing MaxiMet it is suggested that for best accuracy a declination figure should be entered. Use of the Compass-Corrected Wind Direction readings allows the unit to be installed such that accurate positioning of the MaxiMet north marker is not required.



Gill provide a derived parameter for corrected wind direction and speed information, this derived parameter is based on an algorithm devised by Gill and may not satisfy or meet other known valid standards for correcting a moving object's wind speed and direction heading. Details on the algorithm used are included in Appendix N on page 180.

### 2.11. Compass Declination

Declination is the magnetic declination (the angle between Magnetic North and True North) in degrees. This is a correction factor that is added to the Magnetic North heading from the compass.

Map and declination figures in decimal figures can be obtained from:

<http://www.geosats.com/magdecli.html>

<http://www.ngdc.noaa.gov/geomag/declination.shtml>

### 2.12. Solar (GMX301, GMX501, GMX551)

MaxiMet uses a high quality Hukseflux LPO2 second class Solar Radiation/Pyranometer which complies with ISO 9060. This highly accurate instrument uses thermopile technology to measure hemispherical solar radiation from a 180 degree field of view angle.

### 2.13. GPS Option (GMX200, GMX240, GMX500, GMX550, GMX551, GMX552, GMX600, GMX603)

MaxiMet uses a highly accurate GPS antenna receiver module including a ceramic GPS patch antenna. The module is capable of receiving signals from up to 48 GPS satellites and transferring them into position and timing information. Small size and high-end GPS functionality are combined with low power consumption.

### 2.14. Inclinator (All MaxiMet Models, diagram illustrates a GMX550)

MaxiMet outputs Tilt co-ordinates X and Y in terms of degrees and Z in terms of orientation.

#### Normal Tilt Output

The descriptions below assume that the MaxiMet North marker is facing North. Tilt measurements are always made with respect to the North marker.

- X-Tilt is displayed in degrees with 2 signed integral digits over the range  $\pm 89^\circ$ .
  - +XX indicates that the unit is tipping towards the East.
  - -XX indicates that the unit is tipping towards the West.
- Y-Tilt is displayed in degrees with 2 signed integral digits over the range  $\pm 89^\circ$ .
  - +YY indicates that the unit is tipping towards the North.
  - -YY indicates that the unit is tipping towards the South.
- Z-Orientation is displayed as +1 or -1.
  - +1 (normal upright position ( $\pm 90$  degrees)).
  - -1 (inverted position ( $\pm 90$  degrees)).



#### Check Tilt Function Output

Units with an Inclinator have a more accurate X and Y Tilt 4Hz output that also includes compass heading (on wind output units) that can be configured with a PC terminal program during installation if required.

- X-Tilt is displayed in degrees with up to 2 integral digits and a decimal point over the range  $\pm 89.9^\circ$ .
- Y-Tilt is displayed in degrees with up to 2 integral digits and a decimal point over the range  $\pm 89.9^\circ$ .
- Z-Orientation is displayed as +1 or -1.
- The compass reading (on wind output models) shall be output in degrees (000-359).

### 2.15. Heating Function Option (GMX600, 551, 550, 501, 500, 603)

Many MaxiMet variants that measure ambient temperature and wind speed and direction have the additional option of a function for heating the wind sensor ultrasonic transducers.

#### Heating modes

OFF

AUTO - heating controlled by the ambient temperature sensor and the heating on/off thresholds.

- When the ambient temperature reaches the upper threshold, the heating is disabled.
- When the ambient temperature reaches the lower threshold, the heating is turned ON.
- While the heating is ON, the heating element temperature is maintained to a constant level by adjusting the heater element current draw

**Note:** As default the lower and upper thresholds are set to  $+5^\circ\text{C}$  to  $+10^\circ\text{C}$ . The user can configure these values using Gill's MetSet software, up to a maximum value of  $+10^\circ\text{C}$  for each threshold.

### 2.16. Black Globe Temperature (GMX552)

The heating effect of solar radiation is measured using a black-coated copper globe. There is an internal solid state sensor circuit contained within the black globe that provides digital output signals for temperature.

### 2.17. Wet Bulb Temperature (GMX552 with Wet Bulb Sensor 5437-PK-046 or 5437-PK-047)

A measure of wet bulb temperature is provided by the remote Wet Bulb Sensor. The Wet Bulb Sensor is required to be connected to the GMX552 through the 4-way plug-in connector.

The Wet Bulb Temperature sensor uses a high quality RTD temperature probe covered by a cotton wick to measure the wet bulb temperature. The cotton wick extends into a reservoir which must be filled with distilled water prior to use. Radiation shields surround the reservoir to prevent pre-heating of the water due to solar loading.



To maintain the condition of the reservoir and wick, distilled water must be used in the Wet Bulb Sensor.



The water level within the reservoir must be maintained such that at least some of the wick is covered at all times (the wick should not be allowed to dry out).



The reservoir, wick and temperature probe must be kept clean and free from debris to ensure accurate measurements.

### 2.18. Derived Wet Bulb Globe Temperature (GMX552)

The GMX552 will output a derived value of wet bulb globe temperature calculated from the black globe temperature, ambient temperature and relative humidity.



The derived wet bulb globe temperature will output across an ambient temperature range of -20 °C to 50 °C. Outside of this range, no derived wet bulb globe temperature will be returned.



The derived wet bulb globe temperature provides an indication of the levels of heat-stress for use where low maintenance is required. Use a Wet Bulb Sensor (5437-PK-046 or 5437-PK-047) with the GMX552 where reference quality measurements of wet bulb globe temperature are required.

### 2.19. Wet Bulb Globe Temperature (GMX552 with Wet Bulb Sensor 5437-PK-046 or 5437-PK-047)

The GMX552 will calculate the wet bulb globe temperature according to the ISO standard ISO 7243:2017 when a Wet Bulb Temperature Sensor (5437-PK-046 or 5437-PK-047) is connected.

The wet bulb globe temperature is calculated from the measured wet bulb temperature, black globe temperature and ambient temperature. Wet bulb globe temperature is designed to replicate the effective temperature felt by the human body and can be used as a reference to define safe working conditions in extreme environments.



To ensure that the wet bulb globe temperature is representative, the sensors should be positioned according to any local advice or regulation. If no other direction is provided, it is recommended that the sensors are placed in the same conditions as someone operating in the field (e.g. direct sunlight, free of shadow, unsheltered, height of 1-2m).

## Compact Weather Station

### 3. Pre-Installation

#### 3.1. Equipment supplied

- MaxiMet and associated Rain Gauge/Wet Bulb Temperature Sensor/cables as applicable.
- Installation kit (1405-PK-069) comprising of a 9-way connector kit and 3 off M5 bolts and washers to bolt the unit to a mounting pole.
  - For GMX603: Installation kit comprising of an M12 8-way connector (1957-PK-150) and 3 off M5 bolts and washers to bolt the unit to a mounting pole
- MaxiMet User Manual available to download here: <https://gillinstruments.com/downloads/> (this manual).
- MetSet & Metview software available to download here: <https://gillinstruments.com/downloads/>
- Product Test Report.

#### 3.2. Optional Extras/Spares

Item	Part Number
Cable 3 Pair twisted and shielded wires, 24 AWG, per metre.	026-02660
Cable 4 Pair twisted and shielded wires, 24 AWG, per metre.	026-03156
Cable 15 metres (4 pair twisted and shielded 24 AWG – connector pins attached to one end and stripped wires the other).	1405-10-080
Cable 20 Metre 4 pin connector one end, stripped wires other end, for external rain gauge (use with GMX550/GMX551).	1957-10-066
Cable 20 Metre 4 pin connector one end, 9-way connector the other (for GMX551).	1957-10-064
Connector only, 4-way will fit GMX550 and GMX551.	020-06496
9-way connector and 3 mounting bolts (1 supplied with the unit).	1405-PK-069
0.5m x 50mm aluminium support tube tapped for MaxiMet mounting bolts.	1405-30-056
MaxiMet mounting bracket.	1771-PK-115
Rain Gauge, Kalyx Tipping bucket only (no cable attached).	1957-PK-069
Rain Gauge, Solid State for GMX551 (no cable or connector supplied).	1957-PK-073
PW100 external rain gauge.	5150-0100-000
Cable, PW100 to GMX 55x integration cable, 20m.	5150-PK-039
MaxiMet 1.8m RS232 to USB converter including 5V DC power and communication configuration cable (9-way MaxiMet connector fitted one end and USB connector at the other end).	1957-10-065

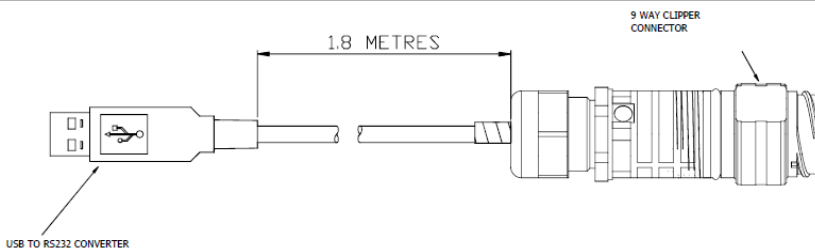

Items	Part Number
<b>GMX552 Accessories Only</b>	
Wet Bulb Temperature Sensor 1.0L	5437-PK-046
Wet Bulb Temperature Sensor 0.5L	5437-PK-047
Wet Bulb Sunshade	5437-PK-048
Replacement PT100 for Wet Bulb Temperature Sensors	5437-PK-054
Replacement 0.5L bottle and retainer for 5437-PK-047	5437-PK-055
Replacement 1.0L bottle and retainer for 5437-PK-046	5437-PK-056
Replacement wick and O-ring for 5437-PK-047 (5-pack)	5437-PK-057
Replacement wick and O-ring for 5437-PK-046 (5-pack)	5437-PK-058
Replacement black globe, locking screw and seals	5437-PK-059
Replacement temperature sensor for black globe	5437-PK-060
<b>GMX603 Accessories Only</b>	
Field Wireable M12 Connector	1957-PK-150
Cable, power and communications cable, 2m with fitted M12 connector at MaxiMet end	1416-PK-011
Cable, power and communications cable, 5m with fitted M12 connector at MaxiMet end	1416-PK-012
Cable, power and communications cable, 10m with fitted M12 connector at MaxiMet end	1416-PK-013
Cable, power and communications cable, 20m with fitted M12 connector at MaxiMet end	1416-PK-014
Cable, Retrofit, M12 to Clipper Assy, M12 on MaxiMet end to male Clipper connector, 0.3m	5150-PK-059
Cable for configuration, MaxiMet to USB for power & comms, 1.8m (M12)	1957-PK-155

### 3.3. Right to change and revise

Gill Instruments reserve the right to change or revise the product without notice or the obligation to notify any person or organisation of such change or revision.

The reproduction and distribution of the documentation and software supplied with this product and the use of its contents is subject to written authorization from Gill Instruments.

### 3.4. Packaging

Whilst the MaxiMet is being moved to its installation site, the unit should be kept in its packaging. Retain the packaging for test bench testing or if the unit has to be moved or returned to Gill Instruments.

### 3.5. Specification

The MaxiMet Specification can be found in Appendix A on page 45.

### 3.6. Downloadable Software

Two software packages are available to help customers use MaxiMet.

- MetSet - this software can be used to set-up the product
- MetView - this software can be used to view the data provided by the product

Both software packages can be downloaded from <https://gillinstruments.com/downloads/>

## Compact Weather Station

### 3.7. Setup Requirements Host System



The default delivery output communication setting of MaxiMet output is RS232 with the COMMS interface setting set for RS232.

Use an RS232 to USB converter e.g. Gill Part No. 1957-10-065, 1.8m configuration cable fitted with 9-way MaxiMet connector and with integral 5V USB connector power for MaxiMet.

For GMX603: The appropriate RS232 to USB converter is Gill Part No. 1957-PK-155.

If an install driver is required for this cable, it can be downloaded from:

<http://www.ftdichip.com/FTDrivers.htm>

#### Alternatively, use:

- An RS232 to USB adaptor or equivalent, for example Connector part ES-U-3001-MB (if not using Gill part 1957-10-065), or connect directly to an RS232 COM port
- A PC running Microsoft Windows and with an internal or external interface compatible with the output from the MaxiMet
- A power supply, 5V to 30V DC at 200mA, if not using the Gill Instruments Configuration cable. Please note, if heating option is turned ON a supply of 10 to 30 DC at 1.6A would be required.
- A 3 pair cable e.g. Belden 9503 (if not using Gill part 1957-10-065), length as required, if not using the Gill Instruments Configuration cable.

### 3.8. Software

Gill MetSet Software used as a configuration tool, will run on PCs with up to and including Windows 11 and can be downloaded free from:

<http://www.gillinstruments.com/main/software.html>

### 3.9. Bench System Test

Prior to physically mounting the MaxiMet in its final location, we strongly recommend that a bench system test be carried out to confirm the system is configured correctly, is fully functional and electrically compatible with the selected host system and cabling (preferably utilising the final cable length). The required data format, units, output rate, and other options should also all be configured at this stage.

Connect the MaxiMet to a PC wired as per RS232 connections in para-5.5

Alternatively use a Gill Configuration cable, Gill Part No. 1957-10-065, with a 9-way connector fitted on one end and USB converter at the other end if required to simplify set up between MaxiMet and a PC.

Open the Gill MetSet software provided to read, check or change settings as per Appendix D on page 91.

Use MetSet to view the data string and confirm that the fields are reading expected values.

### 4. Installation Requirements

#### 4.1. General Installation Guidelines

##### Interference

As with any sophisticated electronics, good engineering practice should be followed to ensure correct operation.

Always check the installation to ensure the MaxiMet is not affected by other equipment operating locally, which may not conform to current standards, e.g. radio/radar transmitters, boat engines, generators etc.

Do NOT mount the MaxiMet in close proximity of high-powered radar or radio transmitters. A site survey may be required if there is any doubt about the strength of external electrical noise.

#### 4.2. Guidelines

- Avoid mounting in the plane of any radar scanner – a vertical separation of at least 2m should be achieved.
- For radio transmitting antennas, the following minimum separations (all round) are suggested:
  - VHF IMM – 1m.
  - MF/HF – 5m.
  - Satcom – 5m (avoid likely lines of sight).
- Ensure the product is correctly earthed in accordance with this manual. Please note that there is no earth connection located on the GMX outer body.
- Use cables recommended by Gill, keeping the length below the maximum allowed. Where the cables are cut and re-connected (junction boxes, plugs and sockets) the cable screen integrity must be maintained, to prevent the EMC performance being compromised.
- If a screened cable is not available between MaxiMet and a rain gauge connection and there are local high RF field strengths, then it is advised to route cabling through a grounded metal conduit.
- Earth loops should not be created – earth the system in accordance with wiring diagrams.
- Ensure the power supply operates to the MaxiMet specification at all times.

## Compact Weather Station

---

### 4.3. Wind

Avoid turbulence caused by surrounding structures that will affect the MaxiMet measurement such as trees, masts and buildings.

The World Meteorological Organisation makes the following recommendations:

- The standard exposure of wind instruments over level open terrain is 10m above the ground. Open terrain is defined as an area where the distance between the sensor and any obstruction is at least 10 times the height of the obstruction.
- If mounting on a building, then theoretically the sensor should be mounted at a height of 1.5 times the height of the building.

If the sensor is to be mounted on a mast boom, part-way up a tower or mast, then the boom should be at least twice as long as the minimum diameter or diagonal of the tower. The boom should be positioned on the prevailing wind side of the tower.

It is important to ensure that the MaxiMet is mounted in a position clear of any structure which may obstruct the airflow or induce turbulence.

Mount MaxiMet so as to have a clear view of prevailing winds.

### 4.4. Compass

MaxiMet should be mounted horizontally and vertically as level as possible.

It is not possible to calibrate for changing magnetic anomalies. Thus, for greatest accuracy, keep the MaxiMet away from sources of local magnetic distortion that will change with time, such as electrical equipment that will be turned on and off, or ferrous bodies that will move. Make sure that MaxiMet is not mounted close to areas that may be see large sources of local magnetic fields.

Electric motors usually generate magnetic fields that are much stronger than the earth's field. It is recommended that MaxiMet be moved as far away from the motors as possible.

As a guide ensure that MaxiMet is mounted at least 1 metre away from ferrous objects to prevent them influencing the compass reading.

A declination correction factor can be added to the Magnetic North heading from the compass.

Map and declination figures in decimal figures can be obtained from:

<http://www.geosats.com/magdecli.html>

<http://www.ngdc.noaa.gov/geomag/declination.shtml>

### 4.5. GPS

MaxiMet should be mounted horizontally and vertically as level as possible. MaxiMet has a tilt sensor output that can assist with this.

A clear view of the sky is best for an optimal satellite lock. Tree canopy, surrounding hills/mountains, tall buildings, and any mounting structure/mast that obscures the view either overhead or of the horizon can impede reception.

Signal multipath errors can occur if the GPS signal is reflected off objects such as tall buildings or large rock surfaces before it reaches the receiver. This increases the travel time of the signal, thereby causing errors.

Number of satellites visible - the more satellites a GPS receiver is in communication with, the better the accuracy. Buildings, terrain, electronic interference, or sometimes even dense foliage can block signal reception, causing position errors or possibly no position reading at all. GPS units typically will not work indoors or underground.

### 4.6. Solar

MaxiMet should be mounted horizontally and vertically as level as possible during installation for optimal readings. MaxiMet has a tilt sensor output that can assist with this.

A clear view of the sky is best for an optimal solar measurement. Mounting obstructions, tree canopy, hills, mountains and tall buildings that obscure the view either overhead or of the horizon can impede solar readings.

### 4.7. Tilt

Inclinometer Tilt Angle (X and Y planes, 00-89 degrees) and Orientation (Z plane, upright/inverted) can be enabled using MetSet to be output continuously at 1Hz in the data string to level the sensor horizontally. See also 2.13 on page 13 for Inclinometer and Tilt information.

There is also a Check Tilt function that may be enabled using a terminal program that solely outputs Tilt Angle (X and Y planes, 0-89.9 degrees) and Z information (plus a compass heading on Wind Models) at 4Hz if this level of accuracy is required.

If it is required to mount the unit at an angle e.g. 30 degrees then rotate the unit so that the unit north marker points north and the X reading is +00 or -00 degrees. Whilst maintaining the X reading at 00 degrees, angle the unit so that the Y reading is +30 degrees for Northern Hemisphere Locations or -30 degrees for Southern Hemisphere Locations.

### 4.8. Rain

#### Internal Integrated TruMet PW100 Optical Rain Sensor (GMX603)

The solid state rain sensor should ideally be mounted horizontally and vertically as level as possible for optimal readings. MaxiMet has a tilt sensor output that can assist with this.

A clear view of the sky is best for optimal rain measurements. Adjacent mounting obstructions or tall landscape features could impede rain readings.

Please refer to the TruMet PW100 product manual for more information on the operation and best practices associated with installation of this rain sensor. The manual can be found at [gillinstruments.com/downloads](http://gillinstruments.com/downloads)

#### External TruMet PW100 Rain Sensor (GMX550 and GMX551)

Please refer to the TruMet PW100 product manual for specific installation instructions. The manual can be found at [GillInstruments.com/downloads](http://GillInstruments.com/downloads)

An available 20m cable is available for seamless, direct connection between the MaxiMet and the TruMet PW100 (Gill Part Number 5150-PK-039).

## Compact Weather Station

### Kalyx Tipping Bucket Rain Gauge (Optional with GMX550 and GMX551)

**The Kalyx rain gauge tipping bucket mechanism is immobilised before shipping to prevent damage in transit. To release the mechanism,** remove the funnel from its base by unscrewing the three nylon thumbscrews. Remove the piece of foam from under the bucket mechanism. This foam may be saved and used whenever the rain gauge is moved.

The Kalyx mounting arrangement options are:

#### ■ Baseplate Mounting

Due to the low weight of the rain gauge (1kg approximately) it must be mounted securely, the use of the baseplate is recommended for this. However, the gauge may be mounted via the three holes in the base to a paving slab for example. It is suggested that rawlbolts are used for this purpose as they provide a means of levelling the rain gauge.

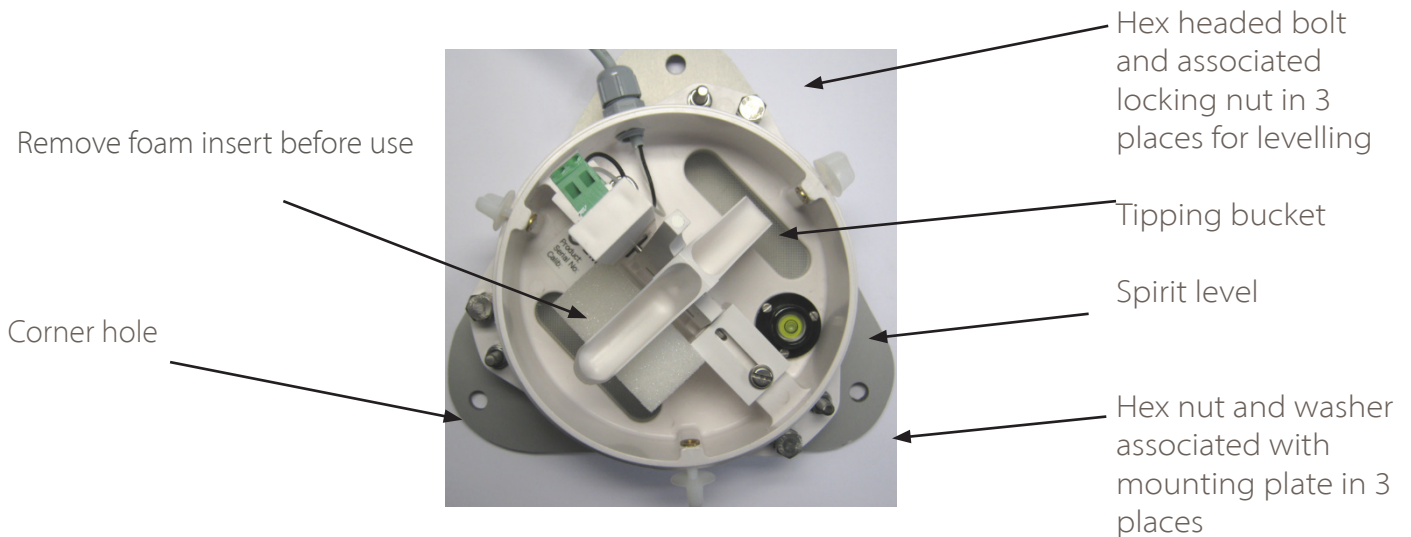

1. Unscrew and remove the 3 hex nuts and washers associated with the mounting plate.
2. Lift off the tipping bucket base assembly to leave the metal baseplate and studs.
3. Fix the baseplate to level ground using the 3 pegs provided through the 3 corner holes. The baseplate may be mounted to hard surfaces like concrete by replacing the 3 supplied pegs with screws and rawlplugs.
4. For temporary mounting on hard surfaces use some bricks or heavy weights on the corners of the baseplate (the height of the weights should be kept as low as possible to cause the minimum interference with the aerodynamics of the rain gauge).
5. Refit the tipping bucket base assembly using the 3 hex nuts and washers.

### Leveling the Base Assembly

Upon completion of the above loosen the 3 leveling hex bolt nuts and adjust the hex bolts align the spirit level bubble to within the centre circle.

Now tighten the hex bolt nuts to lock the hex bolts in position and ensure that the spirit level bubble remains within the centre circle.



**Ensure that the foam insert under the tipping bucket is removed before re-fitting the funnel.**

No two rain gauge designs are ever likely to produce identical results, and identical rain gauges can give slightly different catches, even when sited close to each other.

On GMX550/551 units plug the 20m, 4-way connector cable into the MaxiMet socket.

### Internal Integrated Solid State Rain Sensor (GMX240, GMX400, and GMX600)

The solid state rain sensor should ideally be mounted horizontally and vertically as level as possible for optimal readings. MaxiMet has a tilt sensor output that can assist with this.

A clear view of the sky is best for optimal rain measurements. Adjacent mounting obstructions or tall landscape features could impede rain readings.



The Optical Sensor provides a General Indication only of rainfall levels for use in situations where low maintenance is required. Use a tipping bucket or equivalent with a MaxiMet (e.g. GMX550- and GMX551) where reference quality precipitation measurements are required.

### External Solid State Rain Sensor (GMX550/551)

The external solid state rain sensor should ideally be mounted horizontally and vertically as level as possible for optimal readings. MaxiMet has a tilt sensor output that can assist with this.

A clear view of the sky is best for optimal rain measurements. Adjacent mounting obstructions or tall landscape features could impede rain readings.

Three M5 x 10mm button head screws and three M6 crinkle washers are supplied with the GMX551 system for mounting the Rain sensor to suitable tapped support pole, e.g. see 3.2 on page 15 part 1405-30-056. A protective cap is supplied on the GMX551 4 way outlet socket. This should be fitted at any time that the external rain gauge cable is disconnected from the sensor.

The GMX551 sensor has a +12v dc output present on the 4 way connector to supply power to the external Rain gauge and care should be taken not to short out connector pins.



The Optical Sensor provides a General Indication only of rainfall levels for use in situations where low maintenance is required. Use a tipping bucket or equivalent with a MaxiMet (e.g. GMX550- and GMX551) where reference quality precipitation measurements are required.

### 4.9. Wet Bulb Temperature Sensor (Optional with GMX552)

The Wet Bulb Temperature Sensor (5437-PK-046 or 5437-PK-047) is supplied with two worm drive hose clamps for securing to poles of 38.1mm (1 1/2") to 50.8mm (2"). During installation, these should be threaded through the pole bracket and tightened to 6Nm using a 7mm A/F driver or flat balde screw driver.

To connect the Wet Bulb Temperature sensor to the GMX552, connect the 4-way connector into the socket on the MaxiMet.

Prior to use, the bottle must be filled with **distilled water**.

#### To remove the bottle:

1. Push bottle retainer to one side and support bottle as it will drop down.

#### To re-fit the bottle:

1. Feed the wick into the bottle neck, ensuring it is not kinked or trapped.
2. Push bottle into the socket within the top radiation shade.
3. Pull bottle retainer over the bottle base to its centre.

#### Fitting the optional sunshade (5437-PK-048):

1. Remove the PT100 probe from the assembly (see maintenance, Appendix M, page 168).
2. Place the sunshade onto the temperature sensor bracket.
3. Use the two M4 Pozi Pan screws provided to secure the sunshade to the bracket, tightening to 0.4Nm
4. Re-fit the PT100 sensor, feeding through the hole in the sunshade.

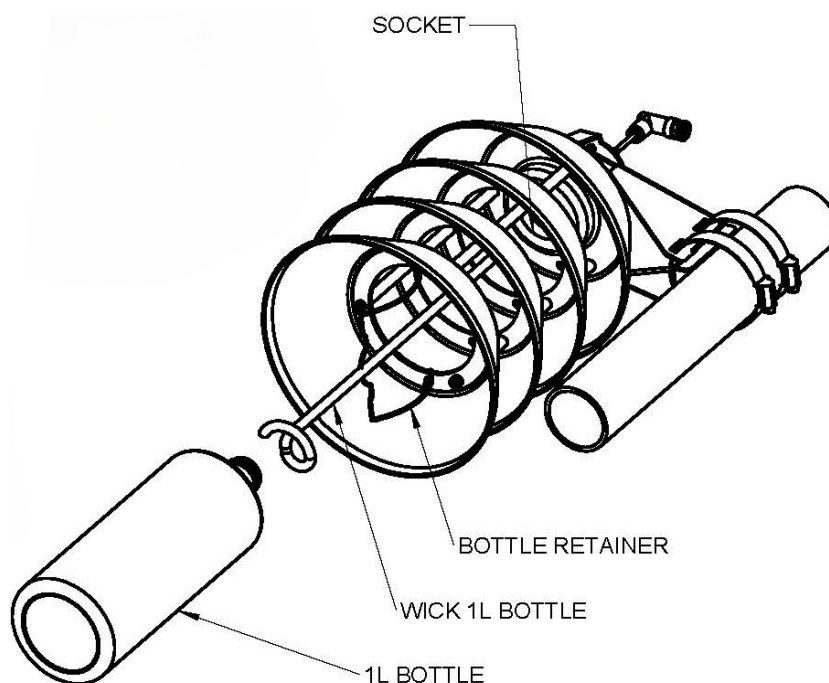

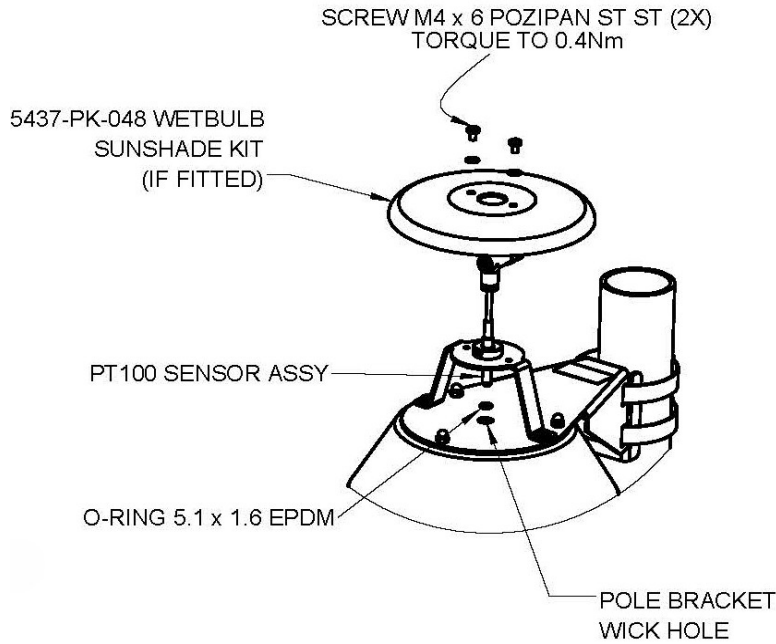

#### 4.10. Black Globe Temperature and Wet Bulb Globe Temperature (GMX552)

MaxiMet should be mounted horizontally and vertically as level as possible during installation for optimal readings. MaxiMet has a tilt sensor output that can assist with this.

Users should primarily follow any instructions provided by their workplace or local authority for how to locate a Heat Stress sensor. If no instructions are provided, it is recommended that the device is positioned in a manner which best represents the typical conditions experienced by someone active in the area (e.g. worker/sportsperson).

- Roughly 1-2m from the ground.
- Exposed to direct sunlight (if applicable)
- Not blocked/obstructed by buildings or structures (reduce shading and allow free air movement)
- Positioned above any representative floor materials (especially radiant materials such as concrete/asphalt)



All heat stress sensors should be allowed to acclimatise for 10-20minutes before any action is taken against the measurements shown.

### 4.11. General Alignment

The MaxiMet anemometer should be set to point north (or to another known reference direction), using the north pointers, which are identified in section 2.3 on page 10.

If the MaxiMet Compass output is enabled by using MetSet (Report page, COMPASSH setting) then a direct Magnetic North compass reading can be used to set MaxiMet north markers to north.

Otherwise MaxiMet need not be aligned precisely if the Compass Corrected Direction (CDIR) readings are to be used.

MaxiMet has a tilt sensor output that can assist with levelling the unit.

### 4.12. Mounting Tube e.g. Gill Part 1405-30-056

A tube 1.75 inches (44.45mm) outside diameter x 3mm wall thickness is recommended. (see figures in 4.12 on page 29).



**It is important that the correct diameter tube is used to prevent damage to the MaxiMet lower moulding when tightening the screws.**

The support tube requires three 3 equally spaced holes, tapped M5, 7.5mm from the top of the tube. Pass the cable (fitted with the 9-way Clipper plug) through the tube.

An optional 500mm long x 44.45 mm outer diameter x 3mm thick aluminium mounting tube pre-drilled with equally spaced tapped holes is available from Gill Instruments (Part No. 1405-30-056).



The customer **must** fit appropriate strain relief to the cable.

Connect the plug by twisting it whilst pushing it gently into the socket on the MaxiMet. When it locates, twist the outer sleeve clockwise to connect and lock the plug.

Fix the MaxiMet to the tube using the 3 stainless steel screws provided. (Maximum mounting screw torque 1.5Nm for Aluminium tubes and 3Nm for Stainless Steel tubes).

For hostile environments, you should select a material suitable for the intended environment – for example, stainless steel 316 for marine use.

For non-hostile environments an aluminium tube can be used.

## Compact Weather Station

### 4.13. Mounting Bracket e.g. Gill Part 1771-PK-115

An optional mounting bracket is available from Gill Instruments Part 1771-PK-115 as per the illustration.

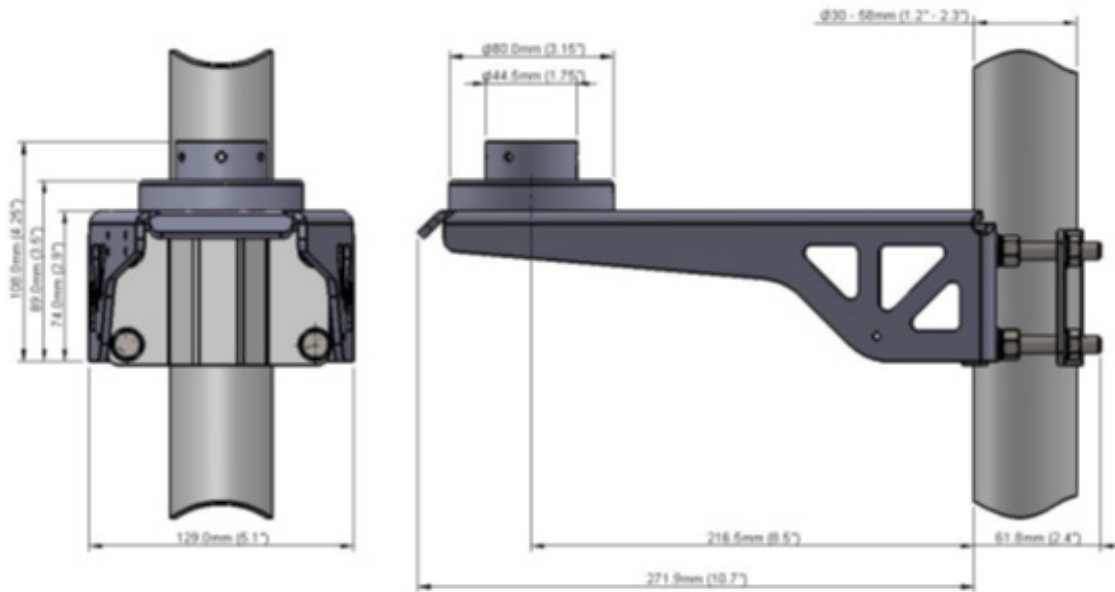

1. Mount the sensor on to the bracket mount and if using a MaxiMet Wind Sensor, align so that the sensor north marker points to the bracket pole.
2. Secure the sensor to its mount using screws and washers supplied in the MaxiMet box.
3. Torque screws to a maximum of 1.5Nm.

The bracket uses a mounting clamp suitable for attaching to a vertical pipe with a diameter of 30-58mm. When mounting the MaxiMet, consider the position, orientation and alignment of the unit. Mount at the top of a pipe to ensure a clear unobstructed measurement view.



The mounting pipe should first be de-greased and when assembling the bracket clamp assembly, the outer clamp nuts need to be tightened evenly to a torque figure of 3 Nm.

The moving plate part of the clamp needs to be reversed for poles below 38 mm diameter. Screw an Earth cable minimum of 6mm<sup>2</sup> to the bracket chassis using screw and terminal tag fixings supplied (see diagram above).

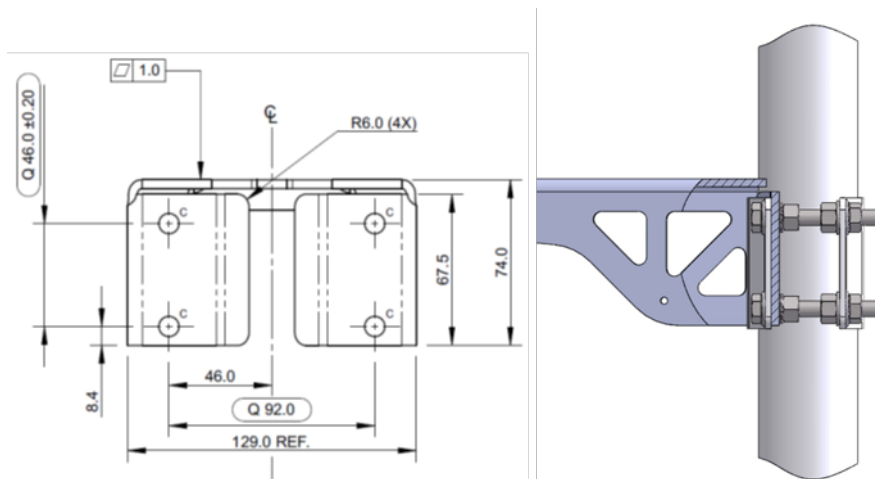

### 4.14. Dimensions (in mm)

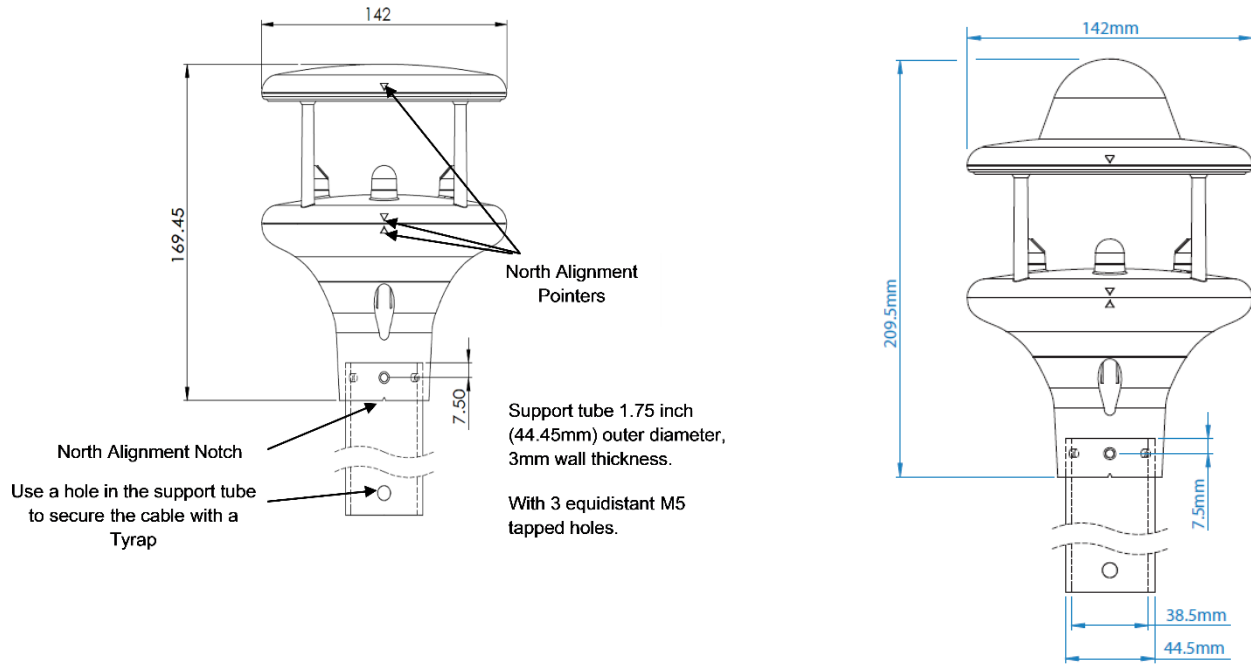

GMX200

GMX240

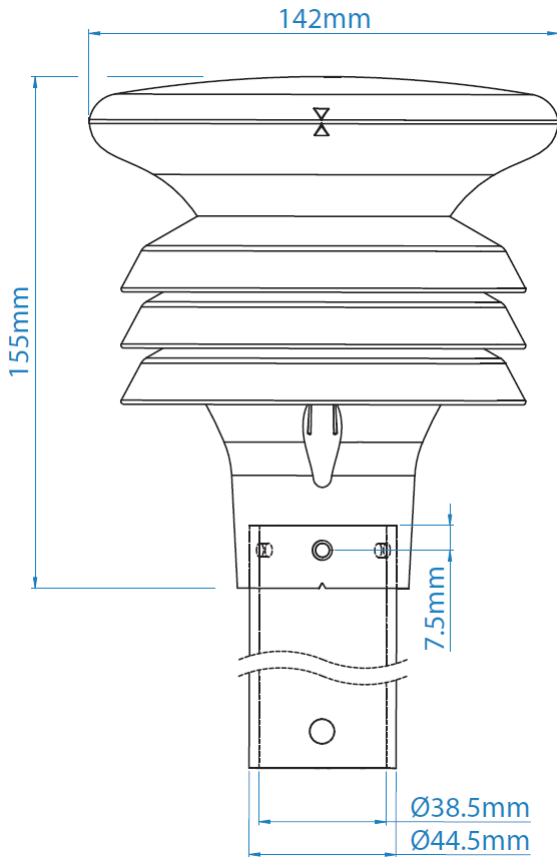

GMX300

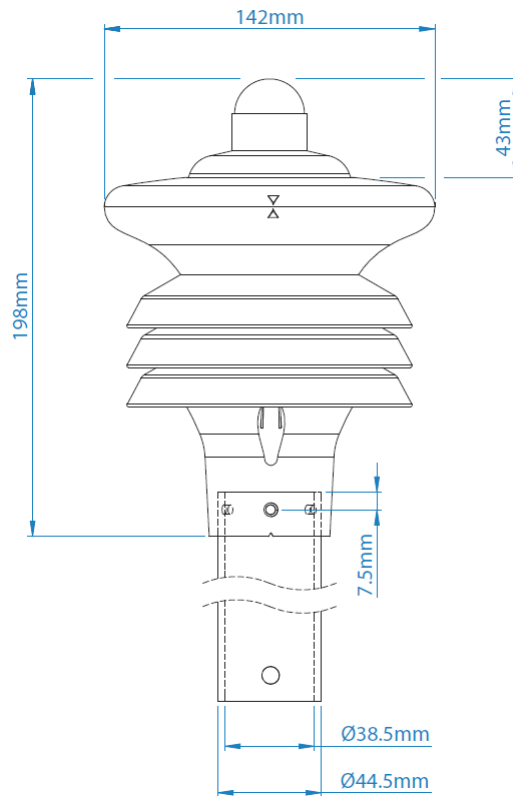

GMX301

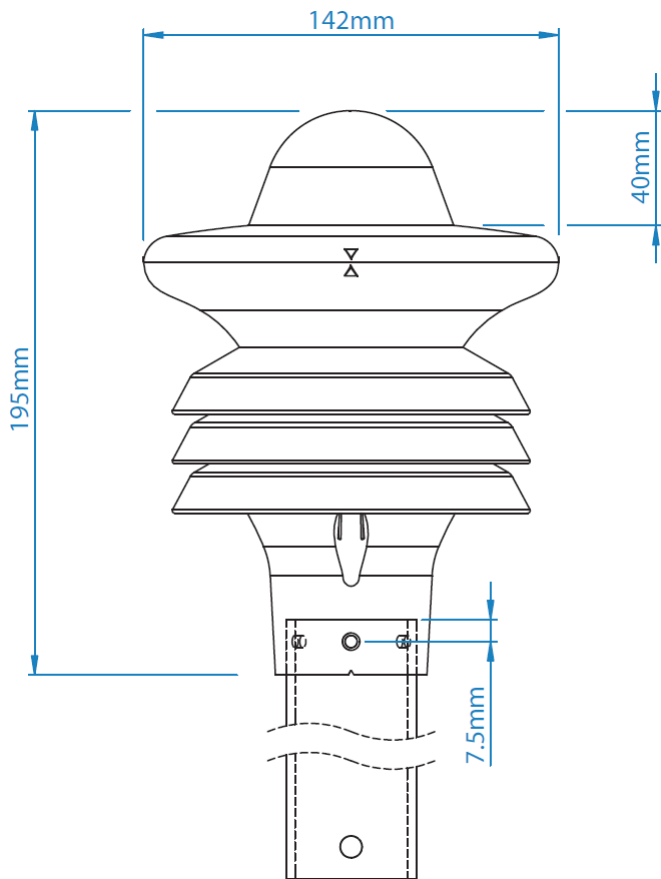

GMX400

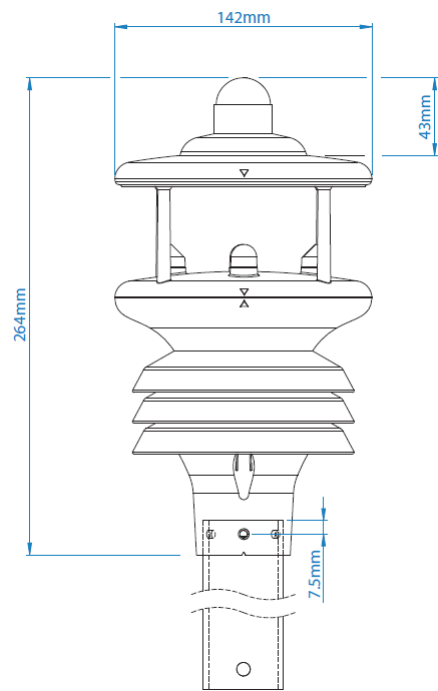

GMX501

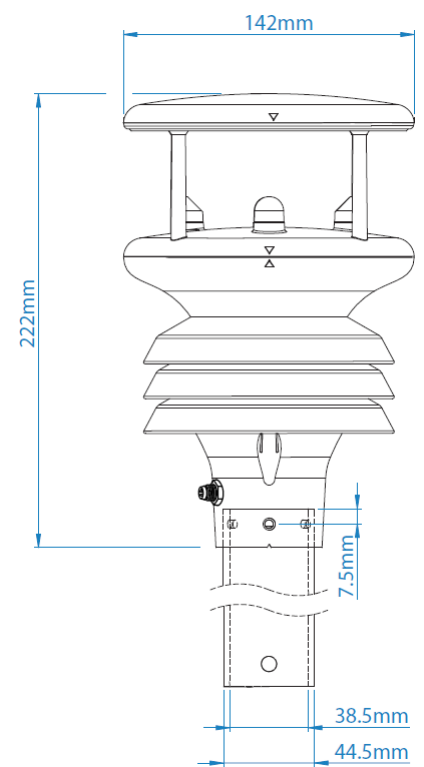

GMX500

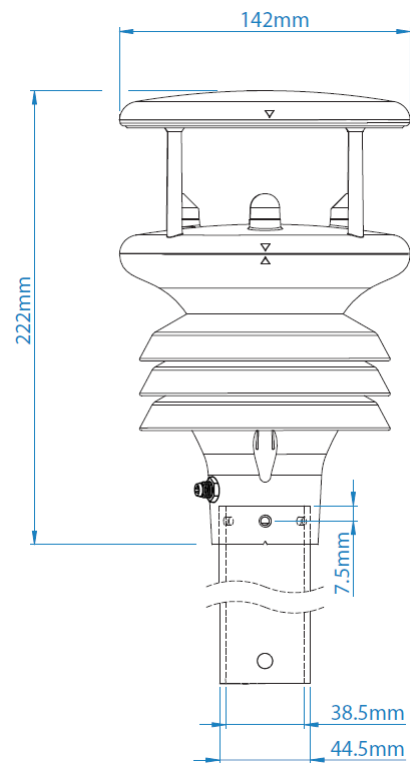

GMX550

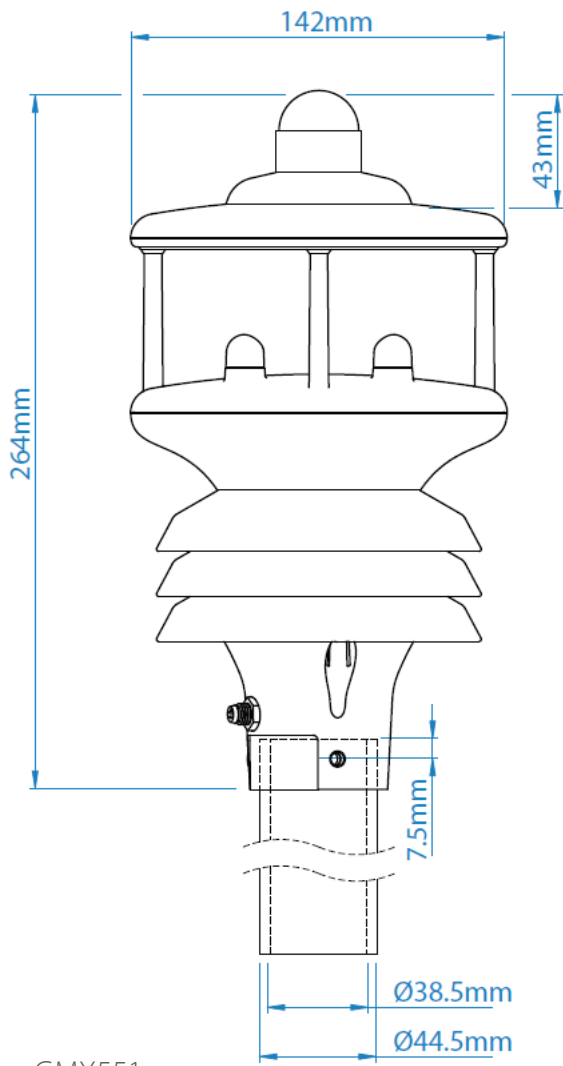

GMX551

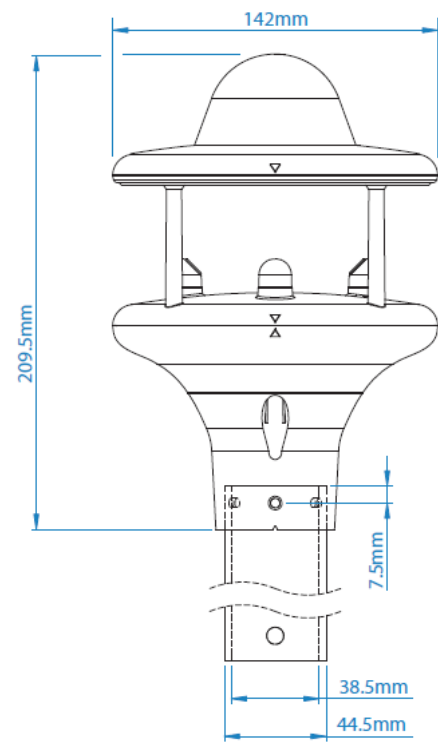

GMX600

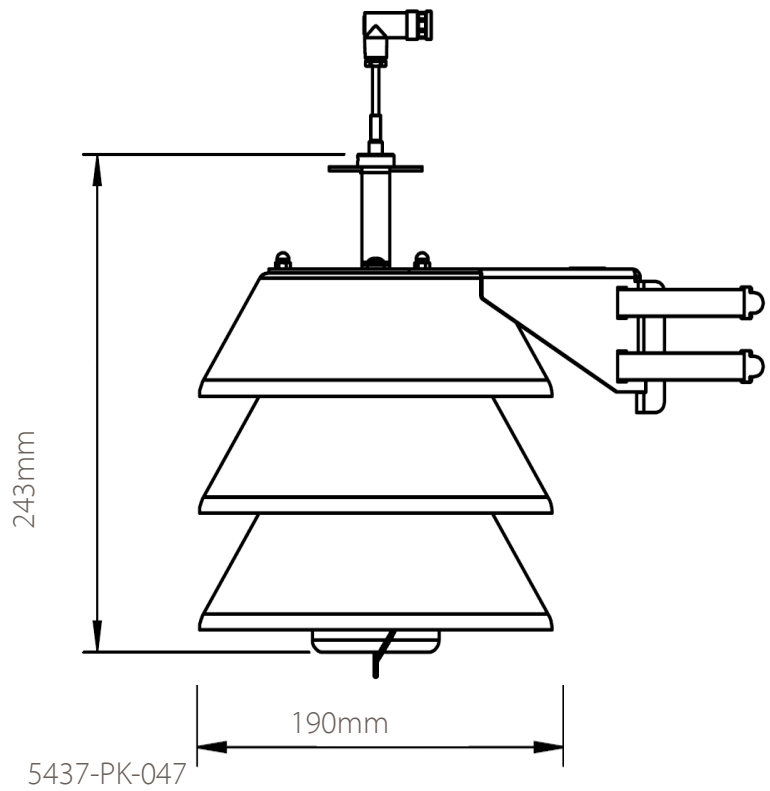
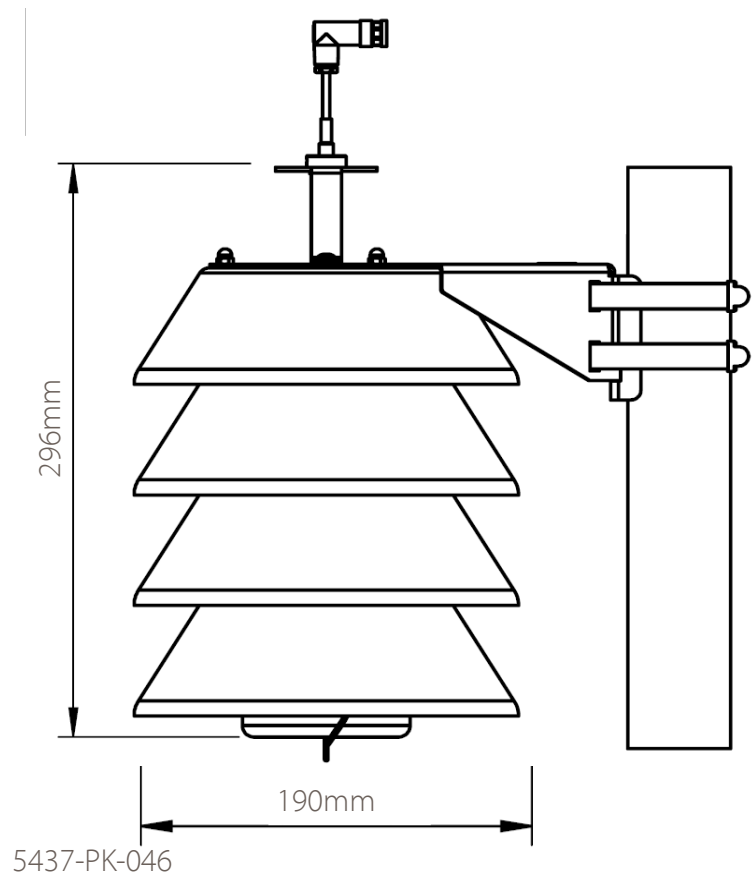
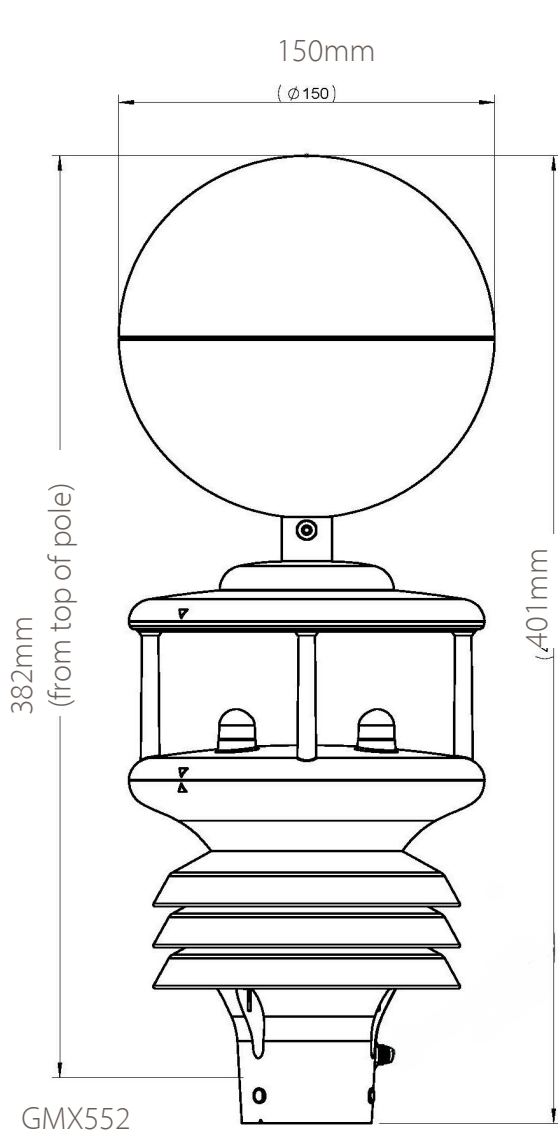

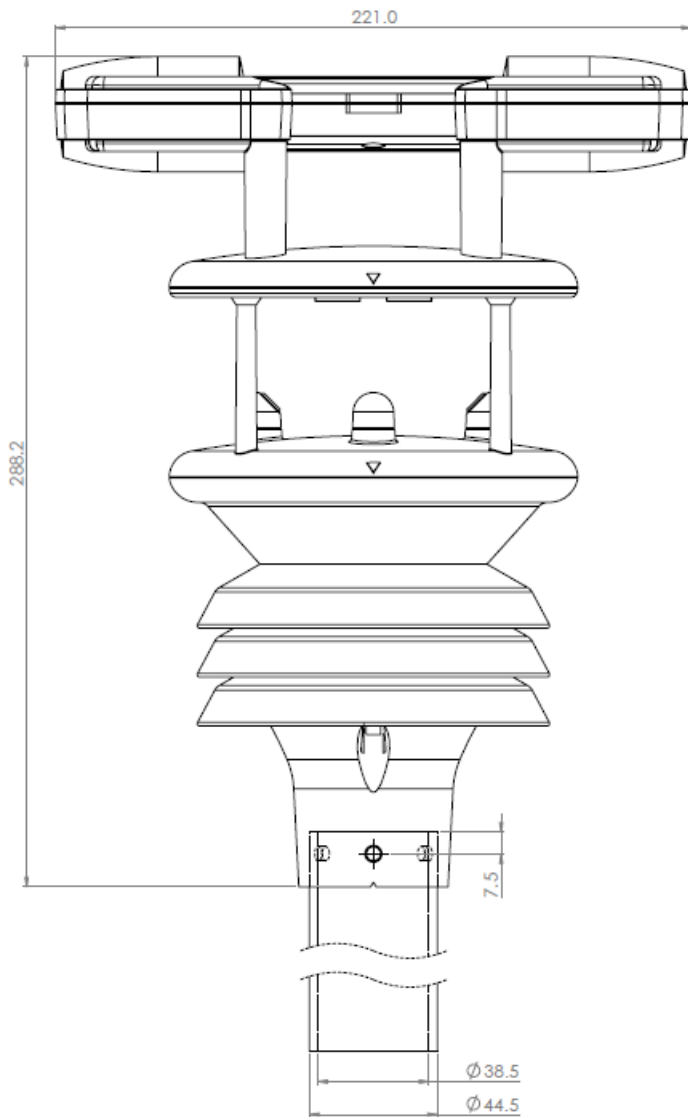

GMX603

### 5. Connector and Pin allocation

Any cable wires not used should be isolated and grounded at the terminating equipment/user end. Digital 0V should be used in conjunction with RS422 Tx/Rx lines in order to improve noise immunity.

For GMX 603 please reference section 5.12 for connector information.

#### 5.1. View of the MaxiMet Connector looking down at the Cable Side

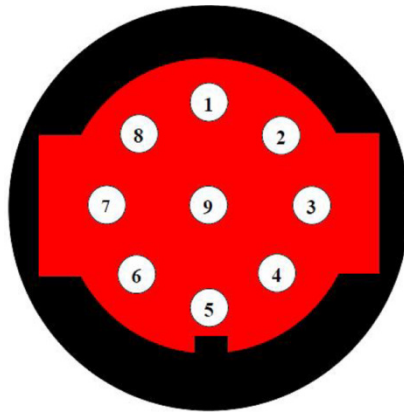

#### 5.2. 9-Way Connector and Cable Connections

9-Way Connector	Signal Designation
1	Signal Ground
2	Supply +ve
3	Supply -ve
4	RS422/485 TXD+
5	RS232 TXD, RS422/RS485 TXD-
6	RS422/RS485 RXD+
7	RS232 RXD, RS422/RS485 RXD-
8	Comms Select Only. Applicable if MaxiMet COMMS Interface Setting set for EXT using MetSet. If MaxiMet is set for EXT Comms, then: - For RS232 connect Pin 8 to Pin 2 +ve. For RS422 leave Pin 8 open circuit or connect to Pin 3 -ve.
9	SDI-12 Data

### 5.3. MaxiMet Units

Supply Voltage: 5V to 30V DC for units without heating  
10V to 30V DC for units with heating

See Appendix A. Technical Specification on page 45 for more details.

### 5.4. Heating power supply

The power required to be supplied **at the unit** is shown below. Any voltage drop between the power supply and the unit should be considered.

Power supply required is peak 1.6A, nominal operational average current draw is 400mA at 12vdc.



**Warning: Hot Surface.** When heating is activated, the heated ultrasonic transducers will get very hot and should not be touched.

## Compact Weather Station

### 5.5. Connecting to a PC using RS232 (Default Setting)

- **MaxiMet default factory communications setting is RS232**
- The recommended cable length for reliable operation is limited to 6.5m (20ft)
- For longer cable runs, we recommend use of RS422 output
- As an alternative method of using MaxiMet with RS232 communications change the MetSet COMMS setting from RS232 to EXT and connect Pin 8 to the +ve supply connection (dotted line connection)
- If EXT is selected and Pin 8 is left open circuit, then note that RS422 comms will be set

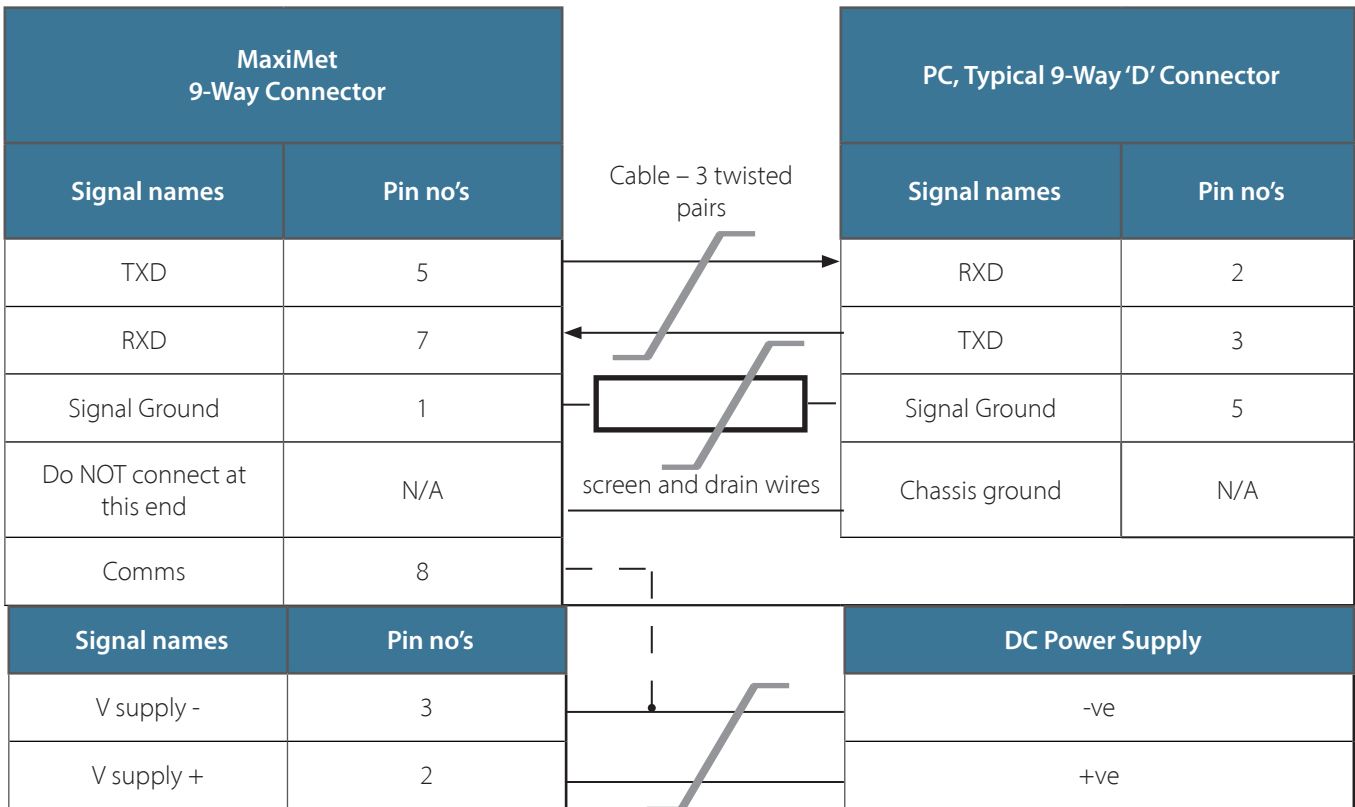

## Compact Weather Station

### 5.6. Connecting to a PC using RS422 (Not a default setting)

- **MaxiMet default factory comms setting is RS232**
- To use the MaxiMet with RS422 comms use MetSet to change the COMMS interface setting to RS422
- Alternatively, use MetSet to change the COMMS interface setting to EXT and leave connector Pin 8 open circuit.
- If EXT is selected and Pin 8 connected to Pin 2 supply positive, then COMMS will change to RS232

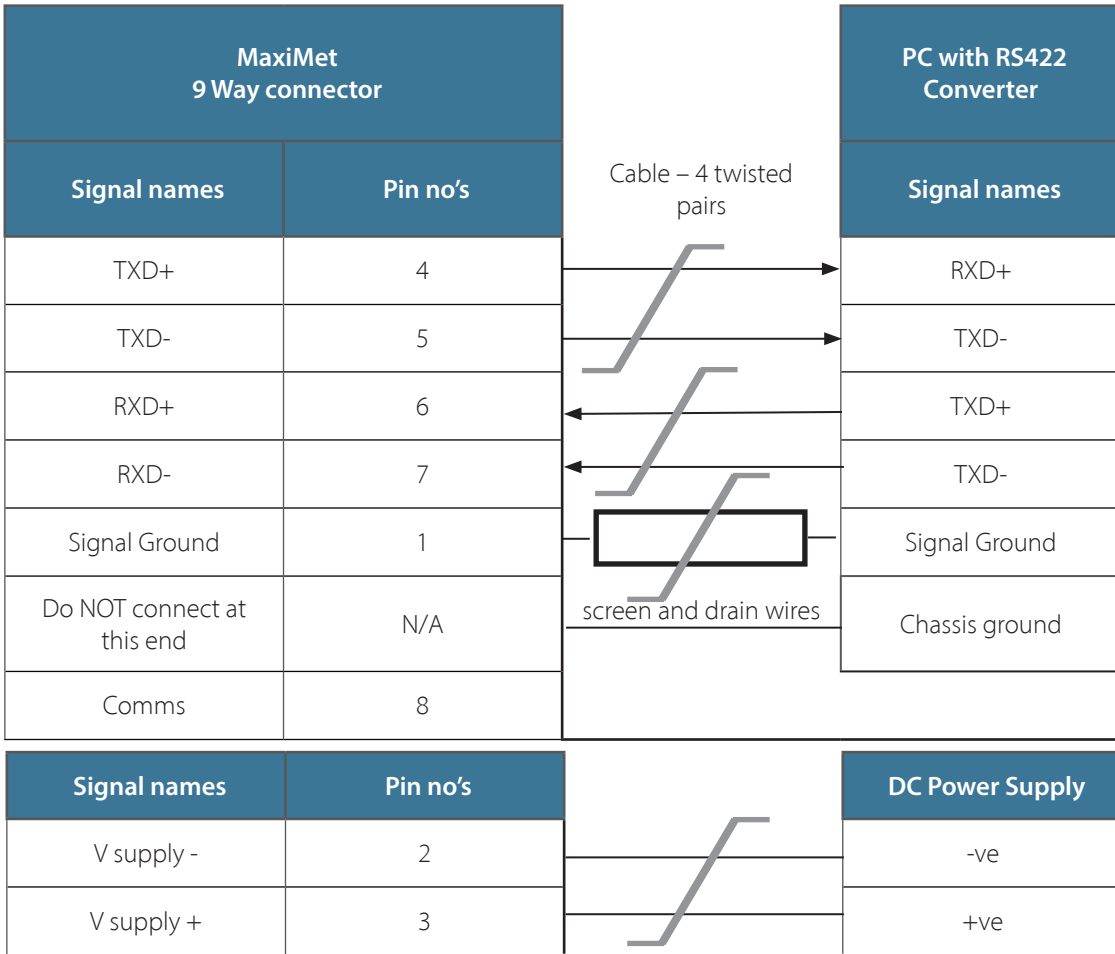

## Compact Weather Station

### 5.7. Using RS485 (not a default setting)

- **MaxiMet default factory comms setting is RS232.**
- To use the MaxiMet with RS485 2 wire communication use MetSet to change the COMMS Interface setting to RS485P2W.
- For using fully networkable Modbus mode, use a two-wire RS-485 bus but **leave the Message setting in CONT (Continuous).**
- Leave connector Pin 8 open circuit.

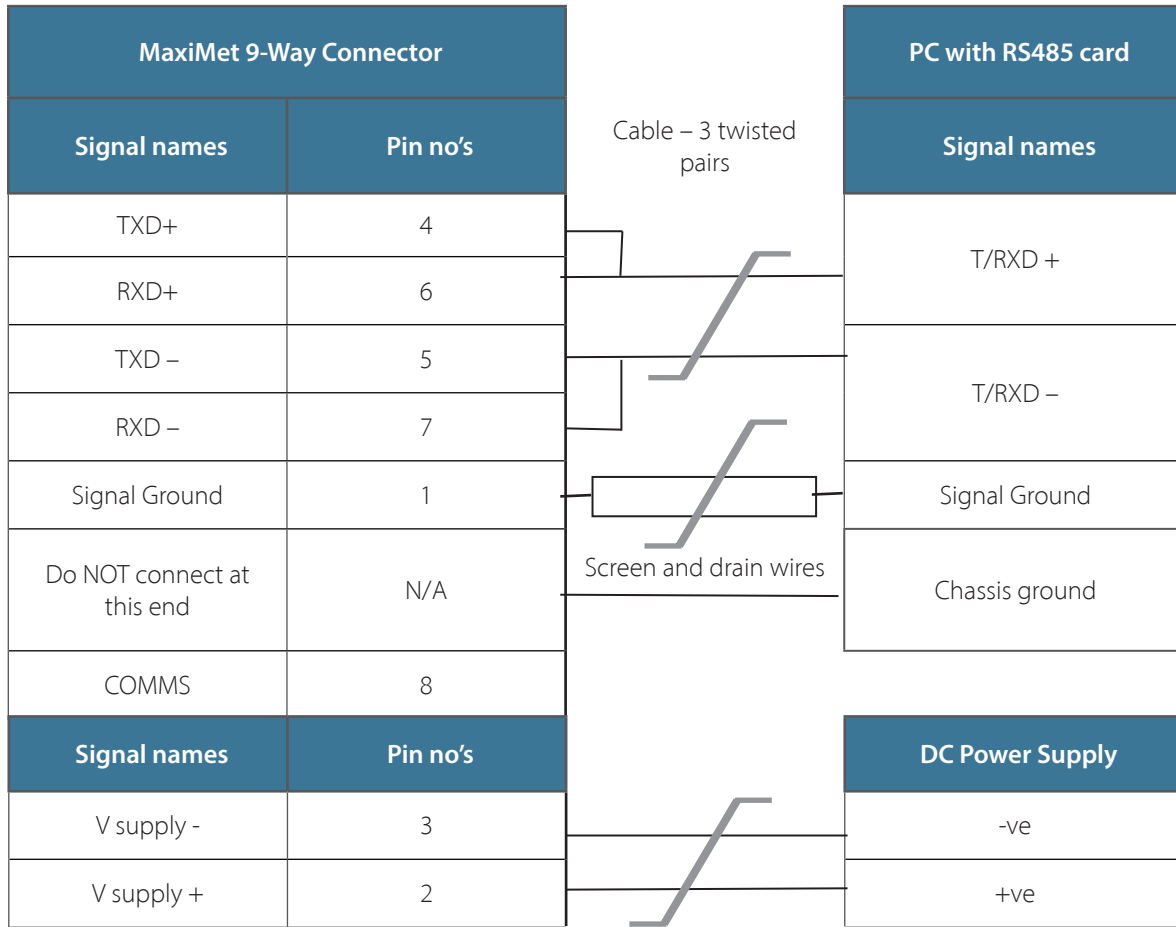

## Compact Weather Station

### 5.8. Using SDI-12 (2 wire network, not a default setting)

- **MaxiMet default factory comms setting is RS232**
- Use MetSet to change the COMMS interface setting to SDI-12

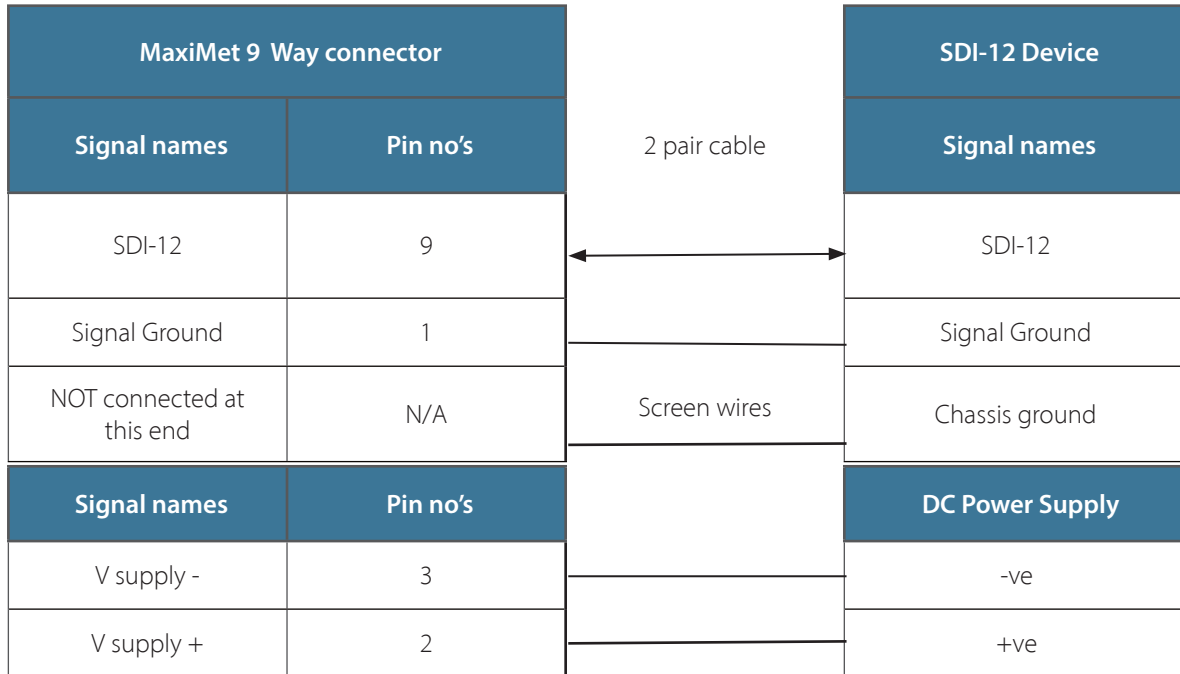

### 5.9. Using the Kalyx Rain Gauge GMX550/GMX551 (or user supplied Rain Gauge)



GMX551 System

4-way connector on a  
20 Metre lead



GMX550



GMX551

### Wiring Details

MaxiMet 4- Way Connector		20m cable supplied with GMX551	Rain Gauge
Signal Names	Pin no's		Signal Names
Rain Gauge	3	Brown ←	Contact
Rain Gauge	1	Blue ←	Contact
No Connection	4	Black	Not Used
No Connection	2	White	Not Used

### GMX551 (Optional Tipping Bucket)

A Kalyx tipping bucket rain gauge can be supplied with the GMX551.

MaxiMet GMX550 and GMX551 are configured with a default tip size is set for 0.000mm/tip.

MaxiMet GMX600 that come with incorporated RG11, are configured with a default tip size of 0.08mm/tip.



**It is essential that the tip-size in the MaxiMet is set according to the tip-size of any connected precipitation sensor. This step must be preformed by the user using MetSet - see Precipitation on page 102.**

A protective cap is supplied on the GMX551 4 way outlet socket. This should be fitted at any time that the external rain gauge cable is disconnected from the sensor.

## Compact Weather Station

### GMX550/GMX551

The GMX550/GMX551 is not supplied with a rain gauge or connecting cable. It is supplied with a 4 way connector.

MaxiMet GMX550 default tip size is set for 0.000mm/tip (to be used with a Rain Yes or No indication Sensor that provides a contact closure for Rain and an open contact for No rain).

For use with a tipping bucket contact closure type change GMX550/GMX551 tip setting using Gill MetSet to match the tipping bucket figure (0.001 to 9.998mm).

A 4 way connector is supplied (Gill Part 020-06496):

Binder M8, Series 768, female, angled connector solder, part # 99 3378 00 04.

Will accept 20 to 26 AWG wire and has a cable outlet for 3.5mm to 5mm diameter wire.

An example 22 AWG, four wire cable would be Lapp 7038861.

Typical suitable 24awg cable characteristics for the above connector are:

Wire Gauge (AWG)	24
Single Lead Structure	32 x 0,1
Cable sheath	4.5mm
Conductor Resistance	79,9Ω/Km

An example of a 5m, 4-way connector and 4-way cable is as follows:

Binder Series 718, part # 77 3708 0000 50004-0500.

Connector illustration and wiring (view looking at the cable connector socket).

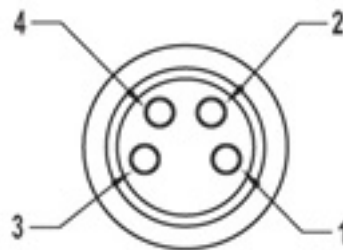

1 = Brown

2 = White

4 = Black

3 = Blue



Note that the connector pin numbering is not in sequence.

A 20m cable with fitted 4-way connector at one end and stripped wires at the other is available as an optional accessory for the GMX550/GMX551 (Gill Part No. 1957-10-066).

A protective cap is supplied on the GMX550/GMX551 4 way outlet socket. This should be fitted at any time that the external rain gauge cable is disconnected from the sensor.

### 5.10. Using the MaxiMet GMX551 with Optional Gill Solid State Rain Gauge



#### Wiring Details

MaxiMet 4-Way Connector		20m cable supplied with GMX551	Solid State Rain Gauge 9 Way Connector	
Signal names	Pin no's		Pin No's	Signal Names
Rain Gauge Contact	3	Blue	1	Contact
Rain Gauge Contact/ Supply 0v	1	Brown	3	Contact/Supply 0v
V supply + (12V)	4	Black	2	+12V
Not Used	2	White	None	No Connection

The GMX551 weather station with optional external Solid State Optical Rain Gauge (Gill Part 1957-00-073) together with a 20m cable (fitted with 9 way and 4-way connectors - Gill part 1957-10-064) to connect the devices together.

MaxiMet GMX551 default tip size is set for 0.000mm/tip.

A protective cap is supplied on the GMX551 4 way outlet socket. This should be fitted at any time that the external rain gauge cable is disconnected from the sensor.

The GMX551 Solid State Rain Gauge input has reverse voltage protection.



**The GMX551 sensor has a +12v dc output present on the 4 way connector and care should be taken not to short out connector pins.**

## Compact Weather Station

### 5.11. Using the MaxiMet GMX552 with Optional Gill Wet Bulb Temperature Sensor (5437-PK-046 or 5437-PK-047)

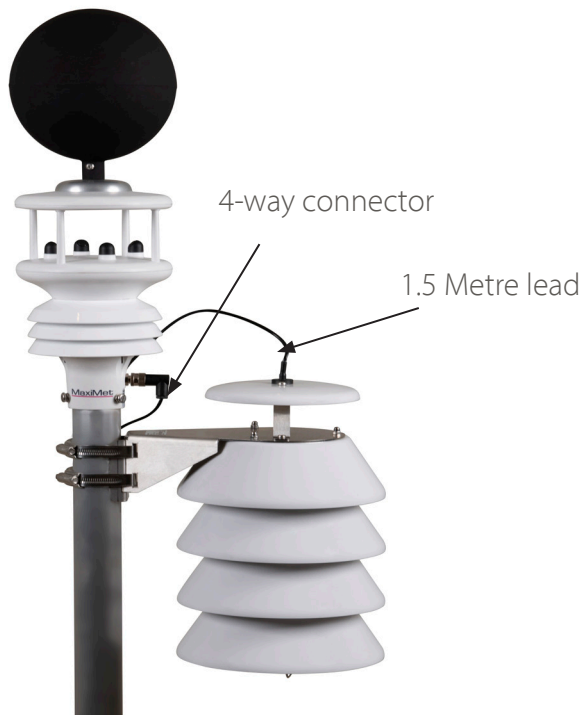

The MaxiMet GMX552 is fitted with a 4-way outlet socket for the purpose of connecting to the Wet Bulb Temperature Sensor.

The Wet Bulb Temperature Sensors (5437-PK-046 and 5437-PK-047) are supplied with a 1.5m cable pre-fitted to an M8 female angled screw connector which complements the socket on the GMX552.

Users may choose to connect an alternative PT100-type wet bulb temperature sensor using the same 4-way outlet socket. To connect an alternative PT100-type sensor, it should be wired to suitable M8 female angled screw connector.

e.g. TE Connectivity Circular Metric M8 Connector, part # T4012008041-000

Connector illustration and wiring (view looking at the cable connector socket).

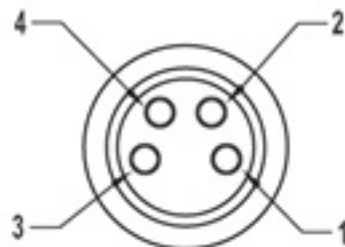

1 = White

2 = White

4 = Red

3 = Red

A protective cap is supplied on the GMX552 4-way outlet socket. This should be fitted at any time that a Wet Bulb Temperature Sensor is disconnected from the MaxiMet.

## Compact Weather Station

### 5.12. GMX 603 Connector

For the GMX 603 variant, the power and communications connector is shown below. It is recommended that:

- Any cable wires not used should be isolated and grounded at the terminating equipment/user end.
- Signal ground should be used in conjunction with RS422 TX/RX lines in order to improve noise immunity.
- The recommended cable length for reliable operation is limited to 6.5m (20ft)
- For longer cable runs, we recommend use of RS422 output

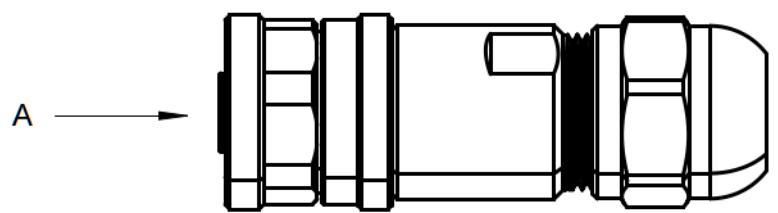
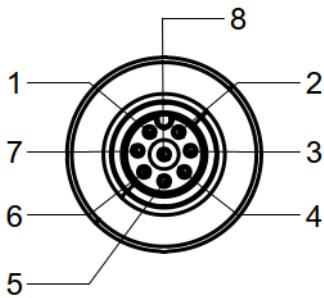

VIEW ON ARROW A



Cable colours below represent Gill supplied cable.

Pin	Wire Colour	RS-232 (Default)	RS-422	RS-485	SDI-12
1	White	Power Ground	Power Ground	Power Ground	Power Ground
2	Brown	Rx-	Rx-	Rx-	-
3	Green	-	Tx+	Tx+	-
4	Yellow	Tx-	Tx-	Tx-	-
5	Grey	-	Rx+	Rx+	-
6	Pink	Power (V+)	Power (V+)	Power (V+)	Power (V+)
7	Blue	Signal Ground	Signal Ground	Signal Ground	Signal Ground
8	Red	-	-	-	SDI-12 Signal

### Appendix A. Technical Specification

Wind Speed	
Range	0.01 - 60m/s
Accuracy	0-10 m/s: $\leq 0.3$ m/s RMSE 10-40 m/s: $\leq 3\%$ RMSE 40-60 m/s: $\leq 5\%$ RMSE
Resolution	0.01m/s
Threshold	0.01m/s
Units of Measure	m/s, km/hr, mph, kts, ft/min
Wind Direction	
Range	0-360°
Accuracy	0.5 m/s-40 m/s: $\leq 3^\circ$ RMSE 40-60 m/s: $\leq 5^\circ$ RMSE
Resolution	1°
Units	Degrees
Compass	
Range	0-360°
Resolution Compass Heading	1°
Units of Measure	Degrees
Accuracy	1° $\pm 3^\circ$
Air Temperature	
Range	-40°C to +70°C with heating
Accuracy	$\pm 0.3^\circ\text{C}$
Resolution	0.1°C
Unit of Measure	°C, °F, K

Relative Humidity	
Range	0-100%
Accuracy	typically, $\pm 2\%$ RH across full range
Resolution	0.1%
Unit of Measure	%, Rh, g/m <sup>3</sup>
Barometric Pressure	
Range	300-1250 hPa
Accuracy 900-1100 hPa, 25-40°C	Absolute (typically) $\pm 0.4$ hPa Relative (typically) $\pm 0.08$ hPa
Resolution	0.1 hPa
Unit of Measure	hPa, mbar, bar, mmHg, InHg
Rain GM240, GMX400, and GMX600 with Solid State Rain Gauge (RG11)	
Precipitation Intensity	0 to 150mm per hour.
Resolution	0.080mm rain/tip (default – adjustable, 0.001 to 9.998mm/tip)
Units of Measure	millimetres, inches
Rain GMX603 with Solid State Rain Gauge (PW100)	
Precipitation accuracy	5%
Precipitation Intensity	0 to 200 mm/hr
Resolution	0.1 mm rain/tip
Units of Measure	Millimeters, inches
Rain GMX550 and GMX551 with External TruMet PW100	
Precipitation accuracy	5%
Precipitation Intensity	0 to 200 mm/hr
Resolution	0.1 mm rain/tip
Units of Measure	Millimeters, inches

Rain GMX551 with External Tipping Bucket Kalyx Rain Gauge	
Precipitation Intensity	0 to 120mm per hour accuracy as below. For use with intensities above 120mm/hr contact EML Instruments.
Resolution	0.200mm rain/tip
Accuracy	98%+ at 20mm/hr, 96%+ at 50mm/hr, 95%+ at 120mm/hr
Units of Measure	millimetres, inches
Rain GMX551 with External Solid State Rain Gauge (RG11)	
Precipitation Intensity	0 to 150mm per hour
Resolution	0.080mm/tip(default – adjustable, 0.001 to 9.998mm/tip)
Units of Measure	millimetres, inches
Digital Input	Contact closure input capable of capturing events up to 1.4Hz
	Minimum Contact Closure time - 11mS
	Minimum time between closures - 500mS
	Capable of reading a switch contact closure providing the total digital switch contact resistance (contact and cabling) is less than 20 ohms
Power Supply Output	+12V DC ±1V DC at up to 100mA for Solid State Rain Gauge.

Rain GMX550 and GMX551 for use with an External Rain Gauge	
Precipitation Intensity	Maximum rate of 1000mm per hour based on 0.2mm per tip
Resolution	As per tip setting (default 0.000mm/tip, adjustable 0.000mm to 9.998mm per tip to match external rain gauge)
Units of Measure	millimetres, inches
Digital Input	Contact closure input (for tipping bucket rain gauge) capable of capturing events up to 1.4Hz
	Minimum Contact Closure time - 11mS
	Minimum time between closures - 500mS
	Capable of reading a switch contact closure providing the total digital switch contact resistance (contact and cabling) is less than 20 ohms

Solar	
Range	300 to 3000nm
Intensity Range	0 to 1600W/m <sup>2</sup>
Resolution	1W/m <sup>2</sup>
Units of Measure	W/m <sup>2</sup>
ISO 9060:2018 Class	Spectrally Flat Class C
GPS	
Horizontal Position accuracy	Less than 2.5m Circular Error Probability (Selective Availability Off)
Time to fix	Less than 45 seconds from unit power up when stationary
Channels	48
Resolution	Longitude and latitude report to 6 decimal places
GPS Time Update	Allow 1 hour upon switch on for GPS time update
Real Time Clock	
Format Date and Time	YYYY-MM-DDThh:mm:ss.s, e.g. 2023-12-25T22:34:56.1
Updating	Manual setting or via GPS option
Power Loss Accuracy	±10 seconds for at least 24 hours after power removed from MaxiMet
Inclinometer	
X Tilt	±89 degrees
Y Tilt	±89 degrees
Z Orientation	+1 Upright, -1 Inverted
Resolution	X-Tilt and Y-Tilt measurements have a resolution of 1 degree
Accuracy	Tilt accuracy ±3° for X-Tilt, Y-Tilt and Z-Orientation
Check Tilt Mode	X, Y and Z output only
X and Y Tilt in Check Tilt Mode	±89.9 degrees, 4 Hz Output

Black Globe Temperature	
Range	-35°C to +70°C
Accuracy	±0.5°C
Resolution	0.1°C
Unit of Measure	°C (default), °F, K

Wet Bulb Temperature (GMX552 with Wet Bulb Temperature Sensor)	
Range	0°C to +70°C
Accuracy	±0.5°C
Resolution	0.1°C
Unit of Measure	°C (default), °F, K

Wet Bulb Globe Temperature (GMX552 with Wet Bulb Temperature Sensor)	
Range	10°C to +50°C
Accuracy	±2°C
Resolution	0.1°C
Unit of Measure	°C (default), °F, K
Notes	Outside of the above range WBGT may be available but will not necessarily conform to the accuracy specifications.

Outputs	
Digital Outputs	Gill ASCII RS232, RS422, RS485* or SDI-12. (RS232 point to point and RS485 2 wire networkable – Modbus RTU/ASCII). Gill ASCII output is 8 bit, No Parity and 1 stop bit.
Baud Rates	1200 (SDI-12), 4800-57600 (ASCII RS232, RS422, RS485*) 9600-19200 (Modbus RTU/ASCII)
Protocols	ASCII, SDI-12 V1.3, NMEA 0183 or Modbus RTU/ASCII
Data Output	1 reading per second (1 Hz), 1 reading per minute, 1 reading per hour or Polled Mode
MaxiMet Status	Status codes provided within the data message string
Power Supply	
Input Voltage (RS232, RS422, RS485)	5V to 30V DC 10 to 30VDC (with heating)
Average Current at 12V DC with Power Saving Mode disabled (default)	GMX200 – 26mA GMX240 - 64mA GMX300 – 5mA GMX301 – 6mA GMX400 – 45mA GMX500 – 26mA GMX501 – 27mA GMX551 (RG) – 65mA (includes the Rain Sensor) GMX550 – 26mA GMX551 - 27mA GMX552 - 26mA GMX600 – 67mA GMX603 - 50 mA For GPS-enabled units allow for an additional 9mA For Heated enabled units allow for 400mA
Average Current at 12V DC in Power Saving Mode and output a reading once per hour	GMX200 – 1.3mA GMX240 – 1.3mA GMX300 - 1.3mA GMX301 – 1.3mA GMX400 - 1.3mA GMX500 – 1.3mA GMX501 – 1.3mA GMX550 – 1.3mA GMX551 – 1.3mA GMX552 - 1.3mA GMX600 – 1.3mA For GPS-enabled units allow for an additional 1mA

Environmental	
Protection Class	IP66
Operating Temperature	-35°C to +70°C (Without heating) -40°C to +70°C (With heating)
CE Marking	YES
Origin	UK

Standard Equipment (supplied with product)	
MaxiMet product	
Mating connector	
MetSet software*, to set-up and configure MaxiMet (comms mode, measurement units, reporting intervals, derived parameters, etc.)	
MetView software*, to view reported parameters	
MaxiMet User Manual*	
* downloadable from Gill Instruments website	

Options	
GPS	Available as an option. Enables reporting of location, height, real-time clock, true wind (for vehicle mounting applications)
Heating	Available as an option for operation where frost & ice accumulation on transducers is possible

## Compact Weather Station

Mechanical	
External Construction	UV stabilized thermoplastic
Fittings	Fit to 30 mm to 58 mm pole or mast
Overall Dimensions and Weights	
GMX551 rain sensor	142mm x 142mm x 142mm, 0.4 kg
GMX200	170mm x 142mm x 142mm, 0.5 kg
GMX240	210mm x 142mm x 142mm, 0.5 kg
GMX300	155mm x 142mm x 142mm, 0.5 kg
GMX301	198mm x 142mm x 142mm, 0.6 kg
GMX400	195mm x 142mm x 142mm, 0.5 kg
GMX500	222mm x 142mm x 142mm, 0.7 kg
GMX501	146mm x 142mm x 142mm, 0.8 kg
GMX550	222mm x 142mm x 142mm, 0.8 kg
GMX551	264mm x 142mm x 142mm, 0.8 kg
GMX552	401mm x 150mm x 150mm, 1.3kg
GMX600	261mm x 142mm x 142mm, 0.8 kg
GMX603	288mm x 221mm x 142mm, 1.1kg
Kalyx Tipping Bucket Rain Gauge	225mm x 245mm x 127mm, 1.2 kg (includes baseplate)
Wet Bulb Temperature Sensor 1L	296mm x 190mm x 190mm, 1kg (unfilled)
Wet Bulb Temperature Sensor 0.5L	243mm x 190mm x 190mm, 0.9kg (unfilled)
Software	
MetSet (Configuration)	Free software available here: <a href="https://gillinstruments.com/downloads/">https://gillinstruments.com/downloads/</a> providing the means of configuration of the MaxiMet
MetView	Free software available here: <a href="https://gillinstruments.com/downloads/">https://gillinstruments.com/downloads/</a> providing the means of viewing MaxiMet data graphically and logging data

### Appendix B. Default Configurations

#### GMX200 Factory Default Data String

Items in red relate to the GPS option unit.

NODE, DIR, SPEED, CDIR, CSPEED, GPSLOCATION, TIME, VOLT, STATUS, CHECK

```
<stx>Q,021,000.01,090,000.01,+50.763004,-001.539898:+3.10,2015-06-05T10:19:30.8,+05.1,0000,<etx> 36
```

Where:-

<stx>	STX
Q	Node Letter
021	Wind Direction
000.01	Wind Speed
090	Corrected Direction
000.01	GPS Corrected Speed
+50.763004	GPS Latitude
-001.539898	GPS Longitude
+3.10	GPS Height location
2015-06-05	Date
T10:19:30.8	Time
+05.1	Supply Voltage
0000	Status
<etx>	ETX
36	Checksum

#### Note:



STX is the Start of String character (ASCII value 2).

ETX is the End of String character (ASCII value 3).

Checksum, the 2 digit Hex Checksum sum figure is calculated from the Exclusive OR of the bytes between (and not including) the STX and ETX characters.

### MetSet Settings Summary

REPORT : NODE DIR SPEED CDIR CSPEED GPSLOCATION TIME VOLT STATUS CHECK		
PROTOCOL : GILL	SENSOR COMPASS : ON	POWER : 0
COMMS : RS232	COMPASSDECL : +000.0	TIME : 2015-06-05T11:04:54
BAUD : 19200	SENSOR GPS : ON	AUTOTIME : ON
NODE : Q	UNITS GPS : MS	TZOFFSET : +00.00
OUTFREQ : 1HZ		PUPMSG STATUS : ON
MSGMODE : CONT		PUPMSG REPORT : ON
ASCTERM : CRLF		PUPMSG UNITS : ON
ECHO : ON		MODBUS : RTU
ALIGN : 0		MODADDR : 1
SENSOR WIND : ON		DATABITS : 8
UNITS WIND : MS		STOPBITS : 1
NODIR : 0.00		PARITY : NONE
AVGSHORT : 60		MODTERM : 10
AVGLONG : 10		MODICT : 1000

## Compact Weather Station

GMX200 Full Data String

### Non-GPS

Node, Relative Wind Direction, Relative Wind Speed, Corrected Wind Direction, Average Relative Wind Direction (WMO), Average Relative Wind Speed (WMO), Relative Gust Direction (WMO), Relative Gust Speed (WMO), Wind Sensor Status, Compass Heading, , Sunrise Time, Solar Noon Time, Sunset Time, Position of the Sun, Twilight (Civil), Twilight (Nautical), Twilight (Astronomical), X-Tilt, Y-Tilt, Z-Orientation, User Information Field, System Date and Time, Supply Voltage, Status, Checksum

```
<stx>Q,048,000.02,106,000,000.00,000,000.00,0100,058,07:58,12:08,16:19,143:  
+09,16:57,17:39,18:19,00,+00,+1,,2018-01-16T09:29:31.1,+05.0,0000,<etx>.22
```

### GPS

Node, Relative Wind Direction, Relative Wind Speed, Corrected Wind Direction, Corrected Wind Speed, Average Relative Wind Direction (WMO), Average Relative Wind Speed (WMO), Relative Gust Direction (WMO), Relative Gust Speed (WMO), Average Corrected Wind Direction (WMO), Average Corrected Wind Speed (WMO), Corrected Gust Direction (WMO), Corrected Gust Speed (WMO), Wind Sensor Status, Compass Heading, GPS Location, GPS Heading, GPS Speed Over Ground, GPS Sensor Status, Sunrise Time, Solar Noon Time, Sunset Time, Position of the Sun, Twilight (Civil), Twilight (Nautical), Twilight (Astronomical), X-Tilt, Y-Tilt, Z-Orientation, User Information Field, System Date and Time, Supply Voltage, Status, Checksum

```
<stx>Q,222,000.00,061,000.56,000,000.00,000,000.00,000,000.00,000,000.00,0100,055,+50.763328:  
-001.540155:-0002.70,242,000.58,010C,08:01,12:15,16:28,146:  
+11,17:06,17:47,18:26,+00,+01,+1,,2018-01-16T09:50:49.8,+05.0,0004,<etx>.68
```

## Compact Weather Station

### GMX240 Factory Default Data String

Items in red relate to the GPS Option Unit.

NODE, DIR, SPEED, CDIR, **CSPEED**, TOTAL PRECIP, PRECIP INTENSITY, **GPSLOCATION**, TIME, VOLT, STATUS, CHECK

```
<stx>Q,180,000.06,133,000.21,00000.000,000.000,+50.763060:  
-001.540268:+0001.60,2017-11-02T15:07:27.6,+05.0,0004,<etx> 31
```

Where:<stx>	STX
Q	Node Letter
180	Wind Direction
000.06	Wind Speed
133	Corrected Direction
<b>000.21</b>	<b>GPS Corrected Speed</b>
0000.000	Precipitation Total
000.000	Precipitation Intensity
<b>+50.763060</b>	<b>GPS Latitude</b>
<b>-001.540268</b>	<b>GPS Longitude</b>
<b>+0001.60</b>	<b>GPS Height location</b>
2017-11-02	Date
T15:07:27.6	Time
+05.0	Supply Voltage
0004	Status
<etx>	ETX
31	Checksum



#### Note:

STX is the Start of String character (ASCII value 2)

ETX is the End of String character (ASCII value 3)

Checksum, the 2 digit Hex Checksum sum figure is calculated from the Exclusive OR of the bytes between (and not including) the STX and ETX characters.

## Compact Weather Station

### MetSet Default Settings

REPORT : NODE DIR SPEED CDIR CSPEED PRECIPT PRECIPI GPSLOCATION TIME VOLT STATUS CHECK		
PROTOCOL : GILL		POWER : 0
COMMS : RS232		TIME : 2017-11-02T15:07:27
BAUD : 19200		AUTOTIME : ON
NODE : Q	SENSOR COMPASS : ON	TZOFFSET : +00.00
OUTFREQ : 1HZ	COMPASSDECL : +000.0	PUPMSG STATUS : ON
MSGMODE : CONT	SENSOR GPS : ON	PUPMSG REPORT : ON
ASCTERM : CRLF	UNITS GPS : MS	PUPMSG UNITS : ON
ECHO : ON	SENSOR TEMP : ON	MODBUS : RTU
ALIGN : 0	UNITS TEMP : C	MODADDR : 1
SENSOR WIND : ON	SENSOR PRECIP : ON	DATABITS : 8
UNITS WIND : MS	UNITS PRECIP : MM	STOPBITS : 1
NODIR : 0.00		PARITY : NONE
AVGSHORT : 60		MODTERM : 10
AVGLONG : 10		MODICT : 1000

### GMX240 Full Data String

#### Non-GPS

Node, Relative Wind Direction, Relative Wind Speed, Corrected Wind Direction, Average Relative Wind Direction (WMO), Average Relative Wind Speed (WMO), Relative Gust Direction (WMO), Relative Gust Speed (WMO), Wind Sensor Status, Total Precipitation, Precipitation Intensity, Precipitation Status, Compass Heading, Sunrise Time, Solar Noon Time, Sunset Time, Position of the Sun, Twilight (Civil), Twilight (Nautical), Twilight (Astronomical), X-Tilt, Y-Tilt, Z-Orientation, User Information Field, System Date and Time, Supply Voltage, Status, Checksum

```
<stx>Q,269,000.03,311,000,000.00,000,000.00,0100,00000.200,000.200,
N,042,+028,+028,1.2,+012.8,07:54,12:10,16:25,174:+18,17:03,17:45,18:24,+12,-14,+1,2017-01-20T11:46:01.3,+05
.0,0000,<etx> 51 CHECK
```

## Compact Weather Station

### GPS

Node, Relative Wind Direction, Relative Wind Speed, Corrected Wind Direction, Corrected Wind Speed, Average Relative Wind Direction (WMO), Average Relative Wind Speed (WMO), Relative Gust Direction (WMO), Relative Gust Speed (WMO), Average Corrected Wind Direction (WMO), Average Corrected Wind Speed (WMO), Corrected Gust Direction (WMO), Corrected Gust Speed (WMO), Wind Sensor Status, Total Precipitation, Precipitation Intensity, Precipitation Status, Compass Heading, GPS Location, GPS Heading, GPS Speed Over Ground, GPS Sensor Status, Sunrise Time, Solar Noon Time, Sunset Time, Position of the Sun, Twilight (Civil), Twilight (Nautical), Twilight (Astronomical), X-Tilt, Y-Tilt, Z-Orientation, User Information Field, System Date and Time, Supply Voltage, Status, Checksum

```
<stx>Q,269,000.03,311,003.17,000,000.00,000,000.00,000,001.45,135,011.05,0100,000  
00.200,000.200,N,042,+50.762988:-001.539893:-0.80,064,+000.10,010B,+028,+028,1.2,  
+012.8,07:54,12:10,16:25,174:+18,17:03,17:45,18:24,+09,+03,+1,,2017-01-20T11:46:01.3,+05.0, 0000,<etx> 51  
CHECK
```

### GMX300 Factory Default Data String

NODE, PRESS, RH, TEMP, DEWPOINT, TIME, VOLT, STATUS, CHECK  
<stx>Q, 1015.3,041,+022.0,+008.5,2015-06-05T10:19:30.8,+05.1,0000,<etx> 36

Where

<stx>	STX
Q	Node Letter
1015.3	Pressure
041	Relative Humidity
+022.0	Temperature
+008.5	Dewpoint
2015-06-05	Date
T10:19:30.8	Time
+05.1	Supply Voltage
0000	Status
<etx>	ETX
36	Checksum



#### Note:

STX is the Start of String character (ASCII value 2).

ETX is the End of String character (ASCII value 3).

Checksum, the 2 digit Hex Checksum sum figure is calculated from the Exclusive OR of the bytes between (and not including) the STX and ETX characters.

### GMX300 MetSet Default Settings

REPORT : NODE PRESS RH TEMP DEWPOINT TIME VOLT STATUS CHECK		
PROTOCOL : GILL	SENSOR TEMP : ON	POWER : 0
COMMS : RS232	UNITS TEMP : C	TIME : 2015-06-05T11:04:54
BAUD : 19200	SENSOR DEWPOINT : ON	
NODE : Q	UNITS DEWPOINT : C	
OUTFREQ : 1HZ	SENSOR PRESS : ON	PUPMSG STATUS : ON
MSGMODE : CONT	UNITS PRESS : HPA	PUPMSG REPORT : ON
ASCTERM : CRLF	HASL : +00000.00	PUPMSG UNITS : ON
ECHO : ON	HASTN : +00000.00	MODBUS : RTU
DATABITS : 8	SENSOR RH : ON	MODADDR : 1
STOPBITS : 1	UNITS RH : %	MODTERM : 10
PARITY : NONE		MODICT : 1000

### GMX300 Full Data String:

Node, Pressure, Pressure at Sea level, Pressure at Station, Relative Humidity, Temperature, Dewpoint, Absolute Humidity, Heat Index, Air Density, Wet Bulb Temperature, Sunrise Time, Solar Noon Time, Sunset Time, Position of the Sun, Twilight (Civil), Twilight (Nautical), Twilight (Astronomical), X-Tilt, Y-Tilt, Z-Orientation, User Information Field, System Date and Time, Supply Voltage, Status, Checksum

```
<stx>Q,0999.5,0999.5,0999.5,040,+023.3,+009.1,08.45,,1.2,+015.1,07:58,12:08,16:19,162:+15,16:57,17:39,18:19,+00,+01,+1,,2018-01-16T10:55:38.5,+05.1,0000,<etx>.1F
```

## Compact Weather Station

### GMX301 Factory Default Data String

NODE, PRESS, RH, TEMP, DEWPOINT, SOLARRAD, TIME, VOLT, STATUS, CHECK

```
<stx>Q,1015.3,041,+022.0,+008.5,0000,2015-06-05T10:19:30.8,+05.1,0004,<etx> 36
```

Where

<stx>	STX
Q	Node Letter
1015.3	Pressure
041	Relative Humidity
+022.0	Temperature
+008.5	Dewpoint
0000	Solar Radiation
2015-06-05	Date
T10:19:30.8	Time
+05.1	Supply Voltage
0004	Status
<etx>	ETX
36	Checksum



#### NOTE:

STX is the Start of String character (ASCII value 2).

ETX is the End of String character (ASCII value 3).

Checksum, the 2 digit Hex Checksum sum figure is calculated from the Exclusive OR of the bytes between (and not including) the STX and ETX characters.

### GMX301 MetSet Settings Summary

REPORT : NODE PRESS RH TEMP DEWPOINT SOLARRAD TIME VOLT STATUS CHECK		
PROTOCOL : GILL	SENSOR COMPASS : ON	POWER : 0
COMMS : RS232	COMPASSDECL : +000.0	TIME : 2015-06-05T11:04:54
BAUD : 19200	SENSOR TEMP : ON	
NODE : Q	UNITS TEMP : C	
OUTFREQ : 1HZ	SENSOR DEWPOINT : ON	PUPMSG STATUS : ON
MSGMODE : CONT	UNITS DEWPOINT : C	PUPMSG REPORT : ON
ASCTERM : CRLF	SENSOR PRESS : ON	PUPMSG UNITS : ON
ECHO : ON	UNITS PRESS : HPA	MODBUS : RTU
	HASL : +00000.00	MODADDR : 1
	HASTN : +00000.00	DATABITS : 8
	SENSOR RH : ON	STOPBITS : 1
	UNITS RH : %	PARITY : NONE
	SENSOR SOLAR : ON	MODTERM : 10
		MODICT : 1000

## Compact Weather Station

### GMX301 Full Data String:

Node, Pressure, Pressure at Sea level, Pressure at Station, Relative Humidity, Temperature, Dewpoint, Absolute Humidity, Solar Radiation, Sunshine Hours, Heat Index, Air Density, Wet Bulb Temperature, Sunrise Time, Solar Noon Time, Sunset Time, Position of the Sun, Twilight (Civil), Twilight (Nautical), Twilight (Astronomical), X-Tilt, Y-Tilt, Z-Orientation, User Information Field, System Date and Time, Supply Voltage, Status, Checksum

```
<stx>Q,0999.4,0999.4,0999.4,040,+023.3,+009.0,08.41,2155,00.00,,1.2,+015.0,07:58,12:08,16:19,163:+15,16:57,17:39,18:19,+00,+00,+1,,2018-01-16T10:58:40.7,+05.1,0000,<etx>.37
```

### GMX400 Factory Default Data String

NODE, PRESS, RH, TEMP, DEWPOINT, TOTAL, PRECIPT, PRECIPI, TIME, VOLT, STATUS,CHECK.

```
<stx>Q,1015.3,041,+022.0,+008.5,00000.200,000.200,2015-06-05T10:19:30.8,+05.1,0000,<etx> 36
```

Where

<stx>	STX
Q	Node Letter
1015.3	Pressure
041	Relative Humidity
+022.0	Temperature
+008.5	Dewpoint
0000.200	Precipitation Total
000.200	Precipitation Intensity
2015-06-05	Date
T10:19:30.8	Time
+05.1	Supply Voltage
0000	Status
<etx>	ETX
36	Checksum



#### NOTE:

<STX> is the Start of String character (ASCII value 2).

<ETX> is the End of String character (ASCII value 3).

Checksum, the 2 digit Hex Checksum sum figure is calculated from the Exclusive OR of the bytes between (and not including) the STX and ETX characters

### GMX400 MetSet Default Settings

REPORT : PRESS RH TEMP DEWPOINT TOTAL PRECIP PRECIP INTENSITY TIME VOLT STATUS CHECK		
PROTOCOL : GILL	SENSOR TEMP : ON	POWER : 0
COMMS : RS232	UNITS TEMP : C	TIME : 2015-06-05T11:04:54
BAUD : 19200	SENSOR DEWPOINT : ON	PUPMSG STATUS : ON
NODE : Q	UNITS DEWPOINT : C	PUPMSG REPORT : ON
OUTFREQ : 1HZ	SENSOR PRESS : ON	PUPMSG UNITS : ON
MSGMODE : CONT	UNITS PRESS : HPA	MODBUS : RTU
ASCTERM : CRLF	HASL : +00000.00	MODADDR : 1
ECHO : ON	HASTN : +00000.00	DATABITS : 8
	SENSOR RH : ON	STOPBITS : 1
	UNITS RH : %	PARITY : NONE
	PRECIPITATION SENSOR : ON	MODTERM : 10
	PRECIPITATION UNITS : MM	MODICT : 1000
	ARPRECIP: ON	PUPMSG STATUS : ON

### GMX400 Full Data String

Node, Pressure, Pressure at Sea level, Pressure at Station, Relative Humidity, Temperature, Dewpoint, Absolute Humidity, Precipitation Total, Precipitation Intensity, Precipitation Status, Heat Index, Air Density, Wet Bulb Temperature, Sunrise Time, Solar Noon Time, Sunset Time, Position of the Sun, Twilight (Civil), Twilight (Nautical), Twilight (Astronomical), X-Tilt, Y-Tilt, Z-Orientation, User Information Field, System Date and Time, Supply Voltage, Status, Checksum

```
<stx>Q,0999.3,0999.3,0999.3,041,+023.2,+009.3,08.61,00000.000,000.000
,N,,1.2,+015.1,07:58,12:08,16:19,165:+16,16:57,17:39,18:19,+00,+00,
+1,,2018-01-16T11:09:24.0,+05.1,0000,<etx>.7A
```

## Compact Weather Station

### GMX500 Factory Default Data String

Items in red relate to the GPS option unit.

NODE, DIR, SPEED, CDIR, **CSPEED**, PRESS, RH, TEMP, DEWPOINT, **GPSLOCATION**, TIME, VOLT, HEATSTAT, STATUS, CHECK

```
<stx>Q,021,000.01,090,000.01,1015.3,041,+022.0,+008.5,+50.763004:-001.539898:+3.10,2015-06-05T10:19:30.8,+05.1,0000,0004,<etx> 36
```

Where

<stx>	STX
Q	Node Letter
021	Wind Direction
000.01	Wind Speed
090	Corrected Direction
000.01	GPS Corrected Speed
1015.3	Pressure
041	Relative Humidity
+022.0	Temperature
+008.5	Dewpoint
+50.763004	GPS Latitude
-001.539898	GPS Longitude
+3.10	GPS Height location
2015-06-05	Date
T10:19:30.8	Time
+05.1	Supply Voltage
0000	Heater Status (OFF)
0004	Status
<etx>	ETX
36	Checksum



#### NOTE:

STX is the Start of String character (ASCII value 2).

ETX is the End of String character (ASCII value 3).

Checksum, the 2 digit Hex Checksum sum figure is calculated from the Exclusive OR of the bytes between (and not including) the STX and ETX characters.

## Compact Weather Station

### MetSet Default Settings

REPORT : NODE DIR SPEED CDIR CSPEED PRESS RH TEMP DEWPOINT GPSLOCATION TIME VOLT STATUS CHECK		
PROTOCOL : GILL	SENSOR COMPASS : ON	POWER : 0
COMMS : RS232	COMPASSDECL : +000.0	TIME : 2015-06-05T11:04:54
BAUD : 19200	SENSOR GPS : ON	AUTOTIME : ON
NODE : Q	UNITS GPS : MS	TZOFFSET : +00.00
OUTFREQ : 1HZ	SENSOR TEMP : ON	PUPMSG STATUS : ON
MSGMODE : CONT	UNITS TEMP : C	PUPMSG REPORT : ON
ASCTERM : CRLF	SENSOR DEWPOINT : ON	PUPMSG UNITS : ON
ECHO : ON	UNITS DEWPOINT : C	MODBUS : RTU
ALIGN : 0	SENSOR PRESS : ON	MODADDR : 1
SENSOR WIND : ON	UNITS PRESS : HPA	DATABITS : 8
UNITS WIND : MS	HASL : +00000.00	STOPBITS : 1
NODIR : 0.00	HASTN : +00000.00	PARITY : NONE
AVGSHORT : 60	SENSOR RH : ON	MODTERM : 10
AVGLONG : 10	UNITS RH : %	MODICT : 1000

### GMX500 Full Data String:

#### Non GPS

Node, Relative Wind Direction, Relative Wind Speed, Corrected Wind Direction, Average Relative Wind Direction (WMO), Average Relative Wind Speed (WMO), Relative Gust Direction (WMO), Relative Gust Speed (WMO), Wind Sensor Status, Pressure, Pressure at Sea level, Pressure at Station, Relative Humidity, Temperature, Dewpoint, Absolute Humidity, Compass Heading, Wind Chill, Heat Index, Air Density, Wet Bulb Temperature, Sunrise Time, Solar Noon Time, Sunset Time, Position of the Sun, Twilight (Civil), Twilight (Nautical), Twilight (Astronomical), X-Tilt, Y-Tilt, Z-Orientation, User Information Field, System Date and Time, Supply Voltage, Heater Status, Status, Checksum

```
<stx>Q,056,000.04,115,000,000.00,000,000.00,0100,0999.2,0999.2,0999.2,041,+023.2,+009.2,08.56,059,,, 1.2,+015.1,07:58,12:08,16:19,166:+16,16:57,17:39,18:19,+00,+01,+1,2018-01-16T11:13:19.5,+05.0,0000,0000,<etx>.22
```

#### GPS

Node, Relative Wind Direction, Relative Wind Speed, Corrected Wind Direction, Corrected Wind Speed, Average Relative Wind Direction (WMO), Average Relative Wind Speed (WMO), Relative Gust Direction (WMO), Relative Gust Speed (WMO), Average Corrected Wind Direction (WMO), Average Corrected Wind Speed (WMO), Corrected Gust Direction (WMO), Corrected Gust Speed (WMO), Wind Sensor Status, Pressure, Pressure at Sea level, Pressure at Station, Relative Humidity, Temperature, Dewpoint, Absolute Humidity, Compass Heading, GPS Location, GPS Heading, GPS Speed Over Ground, GPS Sensor Status, Wind Chill, Heat Index, Air Density, Wet Bulb Temperature, Sunrise Time, Solar Noon Time, Sunset Time, Position of the Sun, Twilight (Civil), Twilight (Nautical), Twilight (Astronomical), X-Tilt, Y-Tilt, Z-Orientation, User Information Field, System Date and Time, Supply Voltage, Heater Status, Status, Checksum

```
<stx>Q,301,000.01,180,000.08,000,000.00,000,000.00,000,000.00,000,000.00,0100,0998.9,0998.9,0998.9,040,+023.1,+009.0,08.43,058,+50.763112:-001.540188:-0011.90,354,000.09,010B,,,1.2,+014.9,08:01,12:15,16:28,170:+17,17:06,17:47,18:26,+00,+00,+1,2018-01-16T11:33:05.7,+05.0,0000,0004,<etx>.67
```

### GMX501 Factory Default Data String

#### Items in red relate to the GPS Option Unit.

NODE, DIR, SPEED, CDIR, **CSPEED**, PRESS, RH, TEMP, DEWPOINT, SOLARRAD, **GPSLOCATION**, TIME, VOLT, HEATSTAT STATUS, CHECK

```
<stx>Q,021,000.01,090,000.01,1015.3,041,+022.0,+008.5,0000,+50.763004:-001.539898:+3.10,2015-06-05T10:19:30.8,+05.1,0000,0004,<etx> 36
```

Where

<stx>	STX
Q	Node Letter
021	Wind Direction
000.01	Wind Speed
090	Corrected Direction
000.01	GPS Corrected Speed
1015.3	Pressure
041	Relative Humidity
+022.0	Temperature
+008.5	Dewpoint
0000	Solar Radiation
+50.763004	GPS Latitude
-001.539898	GPS Longitude
+3.10	GPS Height location
2015-06-05	Date
T10:19:30.8	Time
+05.1	Supply Voltage
0000	Heater Status (OFF)
0004	Status
<etx>	ETX
36	Checksum



#### NOTE:

STX is the Start of String character (ASCII value 2).

ETX is the End of String character (ASCII value 3).

Checksum, the 2 digit Hex Checksum sum figure is calculated from the Exclusive OR of the bytes between (and not including) the STX and ETX characters.

### MetSet Default Settings

REPORT : NODE DIR SPEED CDIR CSPEED PRESS RH TEMP DEWPOINT SOLARRAD GPSLOCATION TIME VOLT STATUS CHECK		
PROTOCOL : GILL	SENSOR COMPASS : ON	POWER : 0
COMMS : RS232	COMPASSDECL : +000.0	TIME : 2015-06-05T11:04:54
BAUD : 19200	SENSOR GPS : ON	AUTOTIME : ON
NODE : Q	UNITS GPS : MS	TZOFFSET : +00.00
OUTFREQ : 1HZ	SENSOR TEMP : ON	PUPMSG STATUS : ON
MSGMODE : CONT	UNITS TEMP : C	PUPMSG REPORT : ON
ASCTERM : CRLF	SENSOR DEWPOINT : ON	PUPMSG UNITS : ON
ECHO : ON	UNITS DEWPOINT : C	MODBUS : RTU
ALIGN : 0	SENSOR PRESS : ON	MODADDR : 1
SENSOR WIND : ON	UNITS PRESS : HPA	DATABITS : 8
UNITS WIND : MS	HASL : +00000.00	STOPBITS : 1
NODIR : 0.00	HASTN : +00000.00	PARITY : NONE
AVGSHORT : 60	SENSOR RH : ON	MODTERM : 10
AVGLONG : 10	UNITS RH : %	MODICT : 1000
	SENSOR SOLAR : ON	

### GMX501 Full Data String:

#### Non-GPS

Node, Relative Wind Direction, Relative Wind Speed, Corrected Wind Direction, Average Relative Wind Direction (WMO), Average Relative Wind Speed (WMO), Relative Gust Direction (WMO), Relative Gust Speed (WMO), Wind Sensor Status, Pressure, Pressure at Sea level, Pressure at Station, Relative Humidity, Temperature, Dewpoint, Absolute Humidity, Compass Heading, Solar Radiation, Sunshine Hours, Wind Chill, Heat Index, Air Density, Wet Bulb Temperature, Sunrise Time, Solar Noon Time, Sunset Time, Position of the Sun, Twilight (Civil), Twilight (Nautical), Twilight (Astronomical), X-Tilt, Y-Tilt, Z-Orientation, User Information Field, System Date and Time, Supply Voltage, Heater Status, Status, Checksum

```
<stx>Q,003,000.02,062,000,000.00,000,000.00,0100,0999.3,0999.3,0999.3,041,+023.3,+009.3,08.61,059,0001,00.00,,,1.2,+015.2,07:58,12:08,16:19,161:+15,16:57,17:39,18:19,+00,+00,+1,,2018-01-16T10:50:19.2,+05.0,0000,0000,<etx>.08
```

#### GPS

Node, Relative Wind Direction, Relative Wind Speed, Corrected Wind Direction, Corrected Wind Speed, Average Relative Wind Direction (WMO), Average Relative Wind Speed (WMO), Relative Gust Direction (WMO), Relative Gust Speed (WMO), Average Corrected Wind Direction (WMO), Average Corrected Wind Speed (WMO), Corrected Gust Direction (WMO), Corrected Gust Speed (WMO), Wind Sensor Status, Pressure, Pressure at Sea level, Pressure at Station, Relative Humidity, Temperature, Dewpoint, Absolute Humidity, Compass Heading, GPS Location, GPS Heading, GPS Speed Over Ground, GPS Sensor Status, Solar Radiation, Sunshine Hours, Wind Chill, Heat Index, Air Density, Wet Bulb Temperature, Sunrise Time, Solar Noon Time, Sunset Time, Position of the Sun, Twilight (Civil), Twilight (Nautical), Twilight (Astronomical), X-Tilt, Y-Tilt, Z-Orientation, User Information Field, System Date and Time, Supply Voltage, Heater Status, Status, Checksum

```
<stx>Q,153,000.00,260,000.48,000,000.00,000,000.00,000,000.00,000,000.00,0100,0999.3,0999.3,0999.3,040,+023.3,+009.1,08.50,055,0000,00.00,+50.763012:-001.540143:+0000.20,079,000.49,010B,,,1.2,+015.1,08:01,12:15,16:28,158:+15,17:06,17:47,18:26,+00,+01,+1,,2018-01-16T10:42:27.8,+05.0,0000,0004,<etx>.48
```

## Compact Weather Station

### GMX550 Factory Default Data String

Items in red relate to the GPS Option Unit.

NODE, DIR, SPEED, CDIR, **CSPEED**, PRESS, RH, TEMP, DEWPOINT, TOTAL PRECIP, PRECIP INTENSITY, **GPSLOCATION**, TIME, VOLT, HEATSTAT, STATUS, CHECK

```
<stx>Q,021,000.01,090,000.01,1015.3,041,+022.0,+008.5, 00000.200,000.200,+50.763004:-001.539898:+3.10,2015-06-05T10:19:30.8,+05.1,0000,0004,<etx> 36
```

Where:

<stx>	STX
Q	Node Letter
021	Wind Direction
000.01	Wind Speed
090	Corrected Direction
<b>000.01</b>	<b>GPS Corrected Speed</b>
1015.3	Pressure
041	Relative Humidity
+022.0	Temperature
+008.5	Dewpoint
0000.200	Precipitation Total
000.200	Precipitation Intensity
<b>+50.763004</b>	<b>GPS Latitude</b>
<b>-001.539898</b>	<b>GPS Longitude</b>
<b>+3.10</b>	<b>GPS Height location</b>
2015-06-05	Date
T10:19:30.8	Time
+05.1	Supply Voltage
0000	Heater Status (OFF)
0004	Status
<etx>	ETX
36	Checksum



#### NOTE:

STX is the Start of String character (ASCII value 2)

ETX is the End of String character (ASCII value 3)

Checksum, the 2-digit Hex Checksum sum figure is calculated from the Exclusive OR of the bytes between

(and not including) the STX and ETX characters.

## Compact Weather Station

### MetSet Default Settings

REPORT : NODE DIR SPEED CDIR CSPEED PRESS RH TEMP DEWPOINT PRECIPT PRECIPI GPSLOCATION TIME VOLT, HEATSTAT STATUS CHECK		
PROTOCOL : GILL	SENSOR COMPASS : ON	POWER : 0
COMMS : RS232	COMPASSDECL : +000.0	TIME : 2015-06-05T11:04:54
BAUD : 19200	SENSOR GPS : ON	AUTOTIME : ON
NODE : Q	UNITS GPS : MS	TZOFFSET : +00.00
OUTFREQ : 1HZ	SENSOR TEMP : ON	PUPMSG STATUS : ON
MSGMODE : CONT	UNITS TEMP : C	PUPMSG REPORT : ON
ASCTERM : CRLF	SENSOR DEWPOINT : ON	PUPMSG UNITS : ON
ECHO : ON	UNITS DEWPOINT : C	MODBUS : RTU
ALIGN : 0	SENSOR PRESS : ON	MODADDR : 1
SENSOR WIND : ON	UNITS PRESS : HPA	DATABITS : 8
UNITS WIND : MS	HASL : +00000.00	STOPBITS : 1
NODIR : 0.00	HASTN : +00000.00	PARITY : NONE
AVGSHORT : 60	SENSOR RH : ON	MODTERM : 10
AVGLONG : 10	UNITS RH : %	MODICT : 1000
	SENSOR PRECIP : ON	
	UNITS PRECIP : MM	

### GMX550 Full Data String

#### Non-GPS

Node, Relative Wind Direction, Relative Wind Speed, Corrected Wind Direction, Average Relative Wind Direction (WMO), Average Relative Wind Speed (WMO), Relative Gust Direction (WMO), Relative Gust Speed (WMO), Wind Sensor Status, Pressure, Pressure at Sea level, Pressure at Station, Relative Humidity, Temperature, Dewpoint, Absolute Humidity, Total Precipitation, Precipitation Intensity, Precipitation Status, Compass Heading, Wind Chill, Heat Index, Air Density, Wet Bulb Temperature, Sunrise Time, Solar Noon Time, Sunset Time, Position of the Sun, Twilight (Civil), Twilight (Nautical), Twilight (Astronomical), X-Tilt, Y-Tilt, Z-Orientation, User Information Field, System Date and Time, Supply Voltage, Heater Status, Status, Checksum  
<stx>Q,269,000.03,311,000,000.00,000,000.00,0100,1032.5,1032.5,1032.5,028,+023.0,+003.8,05.90,00000.200,000.200,N,042,+028,+028,1.2,+012.8,07:54,12:10,16:25,174:+18,17:03,17:45,18:24,+12,-14,+1,2017-01-20T11:46:01.3,+05.0,0000,0000,<etx> 51

#### GPS

Node, Relative Wind Direction, Relative Wind Speed, Corrected Wind Direction, Corrected Wind Speed, Average Relative Wind Direction (WMO), Average Relative Wind Speed (WMO), Relative Gust Direction (WMO), Relative Gust Speed (WMO), Average Corrected Wind Direction (WMO), Average Corrected Wind Speed (WMO), Corrected Gust Direction (WMO), Corrected Gust Speed (WMO), Wind Sensor Status, Pressure, Pressure at Sea level, Pressure at Station, Relative Humidity, Temperature, Dewpoint, Absolute Humidity, Total Precipitation, Precipitation Intensity, Precipitation Status, Compass Heading, GPS Location, GPS Heading, GPS Speed Over Ground, GPS Sensor Status, Wind Chill, Heat Index, Air Density, Wet Bulb Temperature, Sunrise Time, Solar Noon Time, Sunset Time, Position of the Sun, Twilight (Civil), Twilight (Nautical), Twilight (Astronomical), X-Tilt, Y-Tilt, Z-Orientation, User Information Field, System Date and Time, Supply Voltage, Heater Status, Status, Checksum

<stx>Q,269,000.03,311,003.17,000,000.00,000,000.00,000,001.45,135,011.05,0100,1032.5,1032.5,1032.5,028,+023.0,+003.8,05.90,00000.200,000.200,N,042,+50.762988:-001.539893:-0.80,064,+000.10,010B,+028,+028,1.2,+012.8,07:54,12:10,16:25,174:+18,17:03,17:45,18:24,+09,+03,+1,2017-01-20T11:46:01.3,+05.0,0000,0004,<etx> 51

## Compact Weather Station

### GMX551 Factory Default Data String

Items in red relate to the GPS Option Unit.

NODE, DIR, SPEED, CDIR, **CSPEED**, PRESS, RH, TEMP, DEWPOINT, TOTAL PRECIP, PRECIP INTENSITY, SOLARRAD, **GPSLOCATION**, TIME, VOLT, HEATSTAT, STATUS, CHECK

```
<stx>Q,021,000.01,090,000.01,1015.3,041,+022.0,+008.5, 00000.200,000.200,0000,+50.763004:-001.539898:+3.10,2015-06-05T10:19:30.8,+05.1,0000,0004,<etx> 36
```

Where:

<stx>	STX
Q	Node Letter
021	Wind Direction
000.01	Wind Speed
090	Corrected Direction
<b>000.01</b>	<b>GPS Corrected Speed</b>
1015.3	Pressure
041	Relative Humidity
+022.0	Temperature
+008.5	Dewpoint
0000.200	Precipitation Total
000.200	Precipitation Intensity
0000	Solar Radiation
<b>+50.763004</b>	<b>GPS Latitude</b>
<b>-001.539898</b>	<b>GPS Longitude</b>
<b>+3.10</b>	<b>GPS Height location</b>
2015-06-05	Date
T10:19:30.8	Time
+05.1	Supply Voltage
0004	Status
<etx>	ETX
36	Checksum



#### NOTE:

STX is the Start of String character (ASCII value 2)

ETX is the End of String character (ASCII value 3)

Checksum, the 2 digit Hex Checksum sum figure is calculated from the Exclusive OR of the bytes between (and not including) the STX and ETX characters

## Compact Weather Station

MetSet Default Settings

REPORT : NODE DIR SPEED CDIR CSPEED PRESS RH TEMP DEWPOINT PRECIPT PRECIPI SOLARRAD GPSLOCATION TIME VOLT STATUS CHECK		
PROTOCOL : GILL	SENSOR COMPASS : ON	POWER : 0
COMMS : RS232	COMPASSDECL : +000.0	TIME : 2015-06-05T11:04:54
BAUD : 19200	SENSOR GPS : ON	AUTOTIME : ON
NODE : Q	UNITS GPS : MS	TZOFFSET : +00.00
OUTFREQ : 1HZ	SENSOR TEMP : ON	PUPMSG STATUS : ON
MSGMODE : CONT	UNITS TEMP : C	PUPMSG REPORT : ON
ASCTERM : CRLF	SENSOR DEWPOINT : ON	PUPMSG UNITS : ON
ECHO : ON	UNITS DEWPOINT : C	MODBUS : RTU
ALIGN : 0	SENSOR PRESS : ON	MODADDR : 1
SENSOR WIND : ON	UNITS PRESS : HPA	DATABITS : 8
UNITS WIND : MS	HASL : +00000.00	STOPBITS : 1
NODIR : 0.00	HASTN : +00000.00	PARITY : NONE
AVGSHORT : 60	SENSOR RH : ON	MODTERM : 10
AVGLONG : 10	UNITS RH : %	MODICT : 1000
	SENSOR PRECIP: ON	
	UNITS PRECIP : MM	
	SENSOR SOLAR ON	

### GMX551 Full Data String (Including Optional Rain Gauges)

#### Non-GPS

Node, Relative Wind Direction, Relative Wind Speed, Corrected Wind Direction, Average Relative Wind Direction (WMO), Average Relative Wind Speed (WMO), Relative Gust Direction (WMO), Relative Gust Speed (WMO), Wind Sensor Status, Pressure, Pressure at Sea level, Pressure at Station, Relative Humidity, Temperature, Dewpoint, Absolute Humidity, Total Precipitation, Precipitation Intensity, Precipitation Status, Compass Heading, Solar Radiation, Sunshine Hours, Wind Chill, Heat Index, Air Density, Wet Bulb Temperature, Sunrise Time, Solar Noon Time, Sunset Time, Position of the Sun, Twilight (Civil), Twilight (Nautical), Twilight (Astronomical), X-Tilt, Y-Tilt, Z-Orientation, User Information Field, System Date and Time, Supply Voltage, Heater Status, Status, Checksum

```
<stx>Q,269,000.03,311,000,000.00,000,000.00,0100,1032.5,1032.5,1032.5,028,+023.0,+003.8,05.90,00000.200,000.200,N,042,0001,01.20,+028,+028,1.2,+012.8,07:54,12:10,16:25,174:+18,17:03,17:45,18:24,+12,-14,+1,2017-01-20T11:46:01.3,+05.0,0000,0000,<etx> 51
```

#### GPS

Node, Relative Wind Direction, Relative Wind Speed, Corrected Wind Direction, Corrected Wind Speed, Average Relative Wind Direction (WMO), Average Relative Wind Speed (WMO), Relative Gust Direction (WMO), Relative Gust Speed (WMO), Average Corrected Wind Direction (WMO), Average Corrected Wind Speed (WMO), Corrected Gust Direction (WMO), Corrected Gust Speed (WMO), Wind Sensor Status, Pressure, Pressure at Sea level, Pressure at Station, Relative Humidity, Temperature, Dewpoint, Absolute Humidity, Total Precipitation, Precipitation Intensity, Precipitation Status, Compass Heading, Solar Radiation, Sunshine Hours, GPS Location, GPS Heading, GPS Speed Over Ground, GPS Sensor Status, Wind Chill, Heat Index, Air Density, Wet Bulb Temperature, Sunrise Time, Solar Noon Time, Sunset Time, Position of the Sun, Twilight (Civil), Twilight (Nautical), Twilight (Astronomical), X-Tilt, Y-Tilt, Z-Orientation, User Information Field, System Date and Time, Supply Voltage, Heater Status, Status, Checksum

```
<stx>Q,269,000.03,311,003.17,000,000.00,000,000.00,000,001.45,135,011.05,0100,1032.5,1032.5,1032.5,028,+023.0,+003.8,05.90,00000.200,000.200,N,042,0001,01.20,+50.762988:-001.539893:-0.80,064,+000.10,010B,+028,+028,1.2,+012.8,07:54,12:10,16:25,174:+18,17:03,17:45,18:24,+09,+03,+1,2017-01-20T11:46:01.3,+05.0,0000,0004,<etx> 51
```

## Compact Weather Station

### GMX552 Factory Default Data String

Items in red relate to the GPS option unit.

NODE, DIR, SPEED, CDIR, **CSPEED**, PRESS, RH, TEMP, DEWPOINT, **GPSLOCATION**, TIME, VOLT, STATUS, CHECK

```
<stx>Q,021,000.01,090,000.01,1015.3,041,+022.0,+008.5,+50.763004:-001.539898:+3.10,2015-06-05T10:19:30.8,+05.1,0004,<etx> 36
```

Where

<stx>	STX
Q	Node Letter
021	Wind Direction
000.01	Wind Speed
090	Corrected Direction
<b>000.01</b>	<b>GPS Corrected Speed</b>
1015.3	Pressure
041	Relative Humidity
+022.0	Temperature
+008.5	Dewpoint
<b>+50.763004</b>	<b>GPS Latitude</b>
<b>-001.539898</b>	<b>GPS Longitude</b>
<b>+3.10</b>	<b>GPS Height location</b>
2015-06-05	Date
T10:19:30.8	Time
+05.1	Supply Voltage
0004	Status
<etx>	ETX
36	Checksum



#### NOTE:

STX is the Start of String character (ASCII value 2).

ETX is the End of String character (ASCII value 3).

Checksum, the 2 digit Hex Checksum sum figure is calculated from the Exclusive OR of the bytes between (and not including) the STX and ETX characters.



The MaxiMet GMX552 does not include heat stress parameters in the default datastring.

Users can add these parameters by using MetSet to configure the device. See Appendix D, page 87.

### MetSet Default Settings

REPORT : NODE DIR SPEED CDIR CSPEED PRESS RH TEMP DEWPOINT GPSLOCATION TIME VOLT STATUS CHECK		
PROTOCOL : GILL	SENSOR COMPASS : ON	POWER : 0
COMMS : RS232	COMPASSDECL : +000.0	TIME : 2015-06-05T11:04:54
BAUD : 19200	SENSOR GPS : ON	AUTOTIME : ON
NODE : Q	UNITS GPS : MS	TZOFFSET : +00.00
OUTFREQ : 1HZ	SENSOR TEMP : ON	PUPMSG STATUS : ON
MSGMODE : CONT	UNITS TEMP : C	PUPMSG REPORT : ON
ASCTERM : CRLF	SENSOR DEWPOINT : ON	PUPMSG UNITS : ON
ECHO : ON	UNITS DEWPOINT : C	MODBUS : RTU
ALIGN : 0	SENSOR PRESS : ON	MODADDR : 1
SENSOR WIND : ON	UNITS PRESS : HPA	DATABITS : 8
UNITS WIND : MS	HASL : +00000.00	STOPBITS : 1
NODIR : 0.00	HASTN : +00000.00	PARITY : NONE
AVGSHORT : 60	SENSOR RH : ON	MODTERM : 10
AVGLONG : 10	UNITS RH : %	MODICT : 1000
	SENSOR WBGT: OFF	
	UNITS WBGT: C	

### GMX552 Full Data String (Including Optional Wet Bulb Temperature Sensors):

#### Non GPS

Node, Relative Wind Direction, Relative Wind Speed, Corrected Wind Direction, Average Relative Wind Direction (WMO), Average Relative Wind Speed (WMO), Relative Gust Direction (WMO), Relative Gust Speed (WMO), Wind Sensor Status, Pressure, Pressure at Sea level, Pressure at Station, Relative Humidity, Temperature, Dewpoint, Absolute Humidity, Compass Heading, Wind Chill, Heat Index, Air Density, Wet Bulb Temperature, Sunrise Time, Solar Noon Time, Sunset Time, Position of the Sun, Twilight (Civil), Twilight (Nautical), Twilight (Astronomical), X-Tilt, Y-Tilt, Z-Orientation, User Information Field, System Date and Time, Supply Voltage, Status, Wet Bulb Temperature (external), Black Globe Temperature, Wet Bulb Globe Temperature, Derived Wet Bulb Globe Temperature, Checksum

```
<stx>Q,056,000.04,115,000,000.00,000,000.00,0100,0999.2,0999.2,0999.2,041,+023.2,+009.2,08.56,059,,  
1.2,+015.1,07:58,12:08,16:19,166:+16,16:57,17:39,18:19,+00,+01,+1,2018-01-16T11:13:19.5,+05.0,0000,+016.0,+  
020.5,+017.4,+015.2,<etx>.22
```

#### GPS

Node, Relative Wind Direction, Relative Wind Speed, Corrected Wind Direction, Corrected Wind Speed, Average Relative Wind Direction (WMO), Average Relative Wind Speed (WMO), Relative Gust Direction (WMO), Relative Gust Speed (WMO), Average Corrected Wind Direction (WMO), Average Corrected Wind Speed (WMO), Corrected Gust Direction (WMO), Corrected Gust Speed (WMO), Wind Sensor Status, Pressure, Pressure at Sea level, Pressure at Station, Relative Humidity, Temperature, Dewpoint, Absolute Humidity, Compass Heading, GPS Location, GPS Heading, GPS Speed Over Ground, GPS Sensor Status, Wind Chill, Heat Index, Air Density, Wet Bulb Temperature, Sunrise Time, Solar Noon Time, Sunset Time, Position of the Sun, Twilight (Civil), Twilight (Nautical), Twilight (Astronomical), X-Tilt, Y-Tilt, Z-Orientation, User Information Field, System Date and Time, Supply Voltage, Status, Wet Bulb Temperature (external), Black Globe Temperature, Wet Bulb Globe Temperature, Derived Wet Bulb Globe Temperature, Checksum

```
<stx>Q,301,000.01,180,000.08,000,000.00,000,000.00,000,000.00,000,000.00,0100,0998.9,0998.9,0998.9,  
040,+023.1,+009.0,08.43,058,+50.763112:-001.540188:-0011.90,354,000.09,010B,,,1.2,+014.9,  
08:01,12:15,16:28,170:+17,17:06,17:47,18:26,+00,+00,+1,2018-01-16T11:33:05.7,+05.0,0004,+016.0,+020.5,+017  
.4,+015.2,<etx>.67
```

## Compact Weather Station

### GMX600 Factory Default Data String

Items in red relate to the GPS Option Unit.

NODE, DIR, SPEED, CDIR, CSPEED, PRESS, RH, TEMP, DEWPOINT, TOTAL PRECIP, PRECIP INTENSITY, GPSLOCATION, TIME, VOLT, HEATSTAT, STATUS, CHECK

```
<stx>Q,021,000.01,090,000.01,1015.3,041,+022.0,+008.5, 0000.200,000.200,+50.763004:-001.539898:+3.10,2015-06-05T10:19:30.8,+05.1,0000,0004,<etx> 36
```

Where:

<stx>	STX
Q	Node Letter
021	Wind Direction
000.01	Wind Speed
090	Corrected Direction
000.01	GPS Corrected Speed
1015.3	Pressure
041	Relative Humidity
+022.0	Temperature
+008.5	Dewpoint
0000.200	Precipitation Total
000.200	Precipitation Intensity
+50.763004	GPS Latitude
-001.539898	GPS Longitude
+3.10	GPS Height location
2015-06-05	Date
T10:19:30.8	Time
+05.1	Supply Voltage
0000	Heater Status (OFF)
0004	Status
<etx>	ETX
36	Checksum



#### NOTE:

STX is the Start of String character (ASCII value 2)

ETX is the End of String character (ASCII value 3)

Checksum, the 2-digit Hex Checksum sum figure is calculated from the Exclusive OR of the bytes between (and not including) the STX and ETX characters.

### MetSet Default Settings

REPORT : NODE DIR SPEED CDIR CSPEED PRESS RH TEMP DEWPOINT PRECIPT PRECIPI GPSLOCATION TIME VOLT HEATSTAT STATUS CHECK		
PROTOCOL : GILL	SENSOR COMPASS : ON	POWER : 0
COMMS : RS232	COMPASSDECL : +000.0	TIME : 2015-06-05T11:04:54
BAUD : 19200	SENSOR GPS : ON	AUTOTIME : ON
NODE : Q	UNITS GPS : MS	TZOFFSET : +00.00
OUTFREQ : 1HZ	SENSOR TEMP : ON	PUPMSG STATUS : ON
MSGMODE : CONT	UNITS TEMP : C	PUPMSG REPORT : ON
ASCTERM : CRLF	SENSOR DEWPOINT : ON	PUPMSG UNITS : ON
ECHO : ON	UNITS DEWPOINT : C	MODBUS : RTU
ALIGN : 0	SENSOR PRESS : ON	MODADDR : 1
SENSOR WIND : ON	UNITS PRESS : HPA	DATABITS : 8
UNITS WIND : MS	HASL : +00000.00	STOPBITS : 1
NODIR : 0.00	HASTN : +00000.00	PARITY : NONE
AVGSHORT : 60	SENSOR RH : ON	MODTERM : 10
AVGLONG : 10	UNITS RH : %	MODICT : 1000
	SENSOR PRECIP : ON	
	UNITS PRECIP : MM	

## Compact Weather Station

### GMX600 Full Data String

#### Non-GPS

Node, Relative Wind Direction, Relative Wind Speed, Corrected Wind Direction, Average Relative Wind Direction (WMO), Average Relative Wind Speed (WMO), Relative Gust Direction (WMO), Relative Gust Speed (WMO), Wind Sensor Status, Pressure, Pressure at Sea level, Pressure at Station, Relative Humidity, Temperature, Dewpoint, Absolute Humidity, Total Precipitation, Precipitation Intensity, Precipitation Status, Compass Heading, Wind Chill, Heat Index, Air Density, Wet Bulb Temperature, Sunrise Time, Solar Noon Time, Sunset Time, Position of the Sun, Twilight (Civil), Twilight (Nautical), Twilight (Astronomical), X-Tilt, Y-Tilt, Z-Orientation, User Information Field, System Date and Time, Supply Voltage, Heater Status, Status, Checksum

```
<stx>Q,269,000.03,311,000,000.00,000,000.00,0100,1032.5,1032.5,1032.5,028,+023.0,+003.8,05.90,00000.200,000.200,N,042,+028,+028,1.2,+012.8,07:54,12:10,16:25,174:+18,17:03,17:45,18:24,+12,-14,+1,2017-01-20T11:46:01.3,+05.0,0000,0000,<etx> 51
```

#### GPS

Node, Relative Wind Direction, Relative Wind Speed, Corrected Wind Direction, Corrected Wind Speed, Average Relative Wind Direction (WMO), Average Relative Wind Speed (WMO), Relative Gust Direction (WMO), Relative Gust Speed (WMO), Average Corrected Wind Direction (WMO), Average Corrected Wind Speed (WMO), Corrected Gust Direction (WMO), Corrected Gust Speed (WMO), Wind Sensor Status, Pressure, Pressure at Sea level, Pressure at Station, Relative Humidity, Temperature, Dewpoint, Absolute Humidity, Total Precipitation, Precipitation Intensity, Precipitation Status, Compass Heading, GPS Location, GPS Heading, GPS Speed Over Ground, GPS Sensor Status, Wind Chill, Heat Index, Air Density, Wet Bulb Temperature, Sunrise Time, Solar Noon Time, Sunset Time, Position of the Sun, Twilight (Civil), Twilight (Nautical), Twilight (Astronomical), X-Tilt, Y-Tilt, Z-Orientation, User Information Field, System Date and Time, Supply Voltage, Heater Status, Status, Checksum

```
<stx>Q,269,000.03,311,003.17,000,000.00,000,000.00,000,001.45,135,011.05,0100,1032.5,1032.5,1032.5,028,+023.0,+003.8,05.90,00000.200,000.200,N,042,+50.762988:-001.539893:-0.80,064,+000.10,010B,+028,+028,1.2,+012.8,07:54,12:10,16:25,174:+18,17:03,17:45,18:24,+09,+03,+1,2017-01-20T11:46:01.3,+05.0,0000,0004,<etx> 51
```

## Compact Weather Station

### GMX603 Factory Default Data String

Items in red relate to the GPS Option Unit.

NODE, DIR, SPEED, CDIR, CSPEED, PRESS, RH, TEMP, DEWPOINT, TOTAL PRECIP, PRECIP INTENSITY, GPSLOCATION, TIME, VOLT, HEATSTAT, STATUS, CHECK

```
<stx>Q,021,000.01,090,000.01,1015.3,041,+022.0,+008.5, 0000.200,000.200,+50.763004:-001.539898:+3.10,2015-06-05T10:19:30.8,+05.1,0000,0004,<etx> 36
```

Where:

<stx>	STX
Q	Node Letter
021	Wind Direction
000.01	Wind Speed
090	Corrected Direction
000.01	GPS Corrected Speed
1015.3	Pressure
041	Relative Humidity
+022.0	Temperature
+008.5	Dewpoint
0000.200	Precipitation Total
000.200	Precipitation Intensity
+50.763004	GPS Latitude
-001.539898	GPS Longitude
+3.10	GPS Height location
2015-06-05	Date
T10:19:30.8	Time
+05.1	Supply Voltage
0000	Heater Status (OFF)
0004	Status
<etx>	ETX
36	Checksum



#### NOTE:

STX is the Start of String character (ASCII value 2)

ETX is the End of String character (ASCII value 3)

Checksum, the 2-digit Hex Checksum sum figure is calculated from the Exclusive OR of the bytes between (and not including) the STX and ETX characters.

### MetSet Default Settings

REPORT : NODE DIR SPEED CDIR CSPEED PRESS RH TEMP DEWPOINT PRECIPT PRECIPI GPSLOCATION TIME VOLT HEATSTAT STATUS CHECK		
PROTOCOL : GILL	SENSOR COMPASS : ON	POWER : 0
COMMS : RS232	COMPASSDECL : +000.0	TIME : 2015-06-05T11:04:54
BAUD : 19200	SENSOR GPS : ON	AUTOTIME : ON
NODE : Q	UNITS GPS : MS	TZOFFSET : +00.00
OUTFREQ : 1HZ	SENSOR TEMP : ON	PUPMSG STATUS : ON
MSGMODE : CONT	UNITS TEMP : C	PUPMSG REPORT : ON
ASCTERM : CRLF	SENSOR DEWPOINT : ON	PUPMSG UNITS : ON
ECHO : ON	UNITS DEWPOINT : C	MODBUS : RTU
ALIGN : 0	SENSOR PRESS : ON	MODADDR : 1
SENSOR WIND : ON	UNITS PRESS : HPA	DATABITS : 8
UNITS WIND : MS	HASL : +00000.00	STOPBITS : 1
NODIR : 0.00	HASTN : +00000.00	PARITY : NONE
AVGSHORT : 60	SENSOR RH : ON	MODTERM : 10
AVGLONG : 10	UNITS RH : %	MODICT : 1000
	SENSOR PRECIP : ON	
	UNITS PRECIP : MM	

## Compact Weather Station

### GMX603 Full Data String

#### Non-GPS

Node, Relative Wind Direction, Relative Wind Speed, Corrected Wind Direction, Average Relative Wind Direction (WMO), Average Relative Wind Speed (WMO), Relative Gust Direction (WMO), Relative Gust Speed (WMO), Wind Sensor Status, Pressure, Pressure at Sea level, Pressure at Station, Relative Humidity, Temperature, Dewpoint, Absolute Humidity, Total Precipitation, Precipitation Intensity, Precipitation Status, Compass Heading, Wind Chill, Heat Index, Air Density, Wet Bulb Temperature, Sunrise Time, Solar Noon Time, Sunset Time, Position of the Sun, Twilight (Civil), Twilight (Nautical), Twilight (Astronomical), X-Tilt, Y-Tilt, Z-Orientation, User Information Field, System Date and Time, Supply Voltage, Heater Status, Status, Checksum

```
<stx>Q,269,000.03,311,000,000,000,000,000,0100,1032.5,1032.5,1032.5,028,+023.0,+003.8,05.90,00000.200,000.200,N,042,+028,+028,1.2,+012.8,07:54,12:10,16:25,174:+18,17:03,17:45,18:24,+12,-14,+1,2017-01-20T11:46:01.3,+05.0,0000,0000,<etx> 51
```

#### GPS

Node, Relative Wind Direction, Relative Wind Speed, Corrected Wind Direction, Corrected Wind Speed, Average Relative Wind Direction (WMO), Average Relative Wind Speed (WMO), Relative Gust Direction (WMO), Relative Gust Speed (WMO), Average Corrected Wind Direction (WMO), Average Corrected Wind Speed (WMO), Corrected Gust Direction (WMO), Corrected Gust Speed (WMO), Wind Sensor Status, Pressure, Pressure at Sea level, Pressure at Station, Relative Humidity, Temperature, Dewpoint, Absolute Humidity, Total Precipitation, Precipitation Intensity, Precipitation Status, Compass Heading, GPS Location, GPS Heading, GPS Speed Over Ground, GPS Sensor Status, Wind Chill, Heat Index, Air Density, Wet Bulb Temperature, Sunrise Time, Solar Noon Time, Sunset Time, Position of the Sun, Twilight (Civil), Twilight (Nautical), Twilight (Astronomical), X-Tilt, Y-Tilt, Z-Orientation, User Information Field, System Date and Time, Supply Voltage, Heater Status, Status, Checksum

```
<stx>Q,269,000.03,311,003.17,000,000,000,000,000,000,001.45,135,011.05,0100,1032.5,1032.5,1032.5,028,+023.0,+003.8,05.90,00000.200,000.200,N,042,+50.762988:-001.539893:-0.80,064,+000.10,010B,+028,+028,1.2,+012.8,07:54,12:10,16:25,174:+18,17:03,17:45,18:24,+09,+03,+1,2017-01-20T11:46:01.3,+05.0,0000,0004,<etx> 51
```

### Appendix C. Connector and Cable Assembly

The MaxiMet is supplied with a mating 9-way connector.

Part Name	Souriau Clipper Part Number
Connector 9-way	CL1F1201
Backshell	CL101021
Connector Female contact	CM10SC10MQ

#### Preparation

Open the pack of connector parts supplied (Gill Part 1405-PK-069).

Note: that the connector supplies the correct strain relief for cables with an outside diameter of 6-12mm).

Trim back the screened cable outer and screen sleeves 40mm.

Trim back the screen drain wires flush with the outer sleeve.

Strip back the connection wires by 5mm.

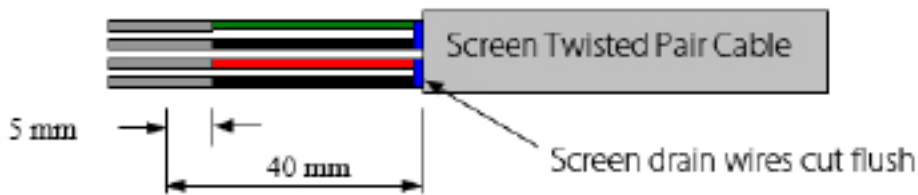

#### Soldering Contacts

Note: that the supplied size 20 contacts are suitable for wire gauges 20 AWG to 24 AWG.

Tin solder the stripped wires.

Solder the contact pins to the wires.

#### Crimping Contacts

Note: that the supplied size 20 contacts are suitable for wire gauges 20 AWG to 24 AWG.

Example crimp tools are:-

Daniels Manufacturing Corporation Tool AF8 and Turret TH1A.

<https://dmctools.com/af8> or

Astro Tool Corporation Crimp tool 615708 and Turret 615709.

<https://www.astrotool.com/products/615708-m22520-1-01-crimping-tool-dmc-af8/>

<https://www.astrotool.com/products/615709-m22520-1-02-turret-head-dmc-th1a/>

Lightly twist the stripped wires (do not solder the wires).

Insert the wire into the supplied contact barrel and ensure that it can be seen through the contact inspection hole.

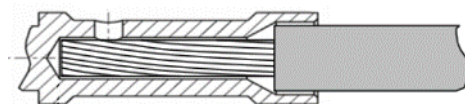

## Compact Weather Station

With the crimp tool fully open place the contact and wire into the crimp tool barrel. Fully close the crimp tool allowing it to re-open on its own. Visibly check that the wire is visible through the inspection hole.

### Connector Assembly

Put the parts on the cable in the order as shown below.



Whilst squeezing the red retainer in the direction of ARROWS A, pull in the direction of ARROW B.

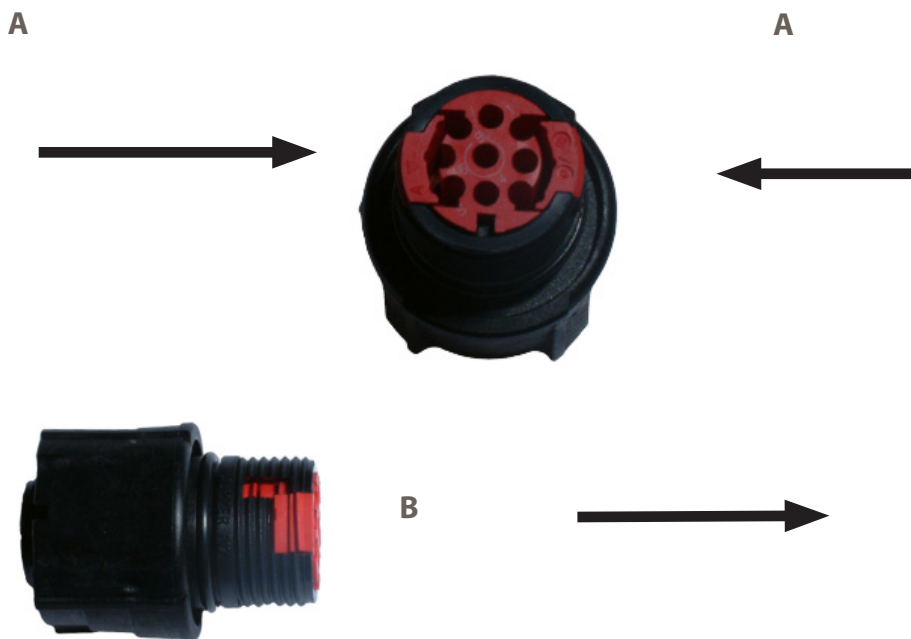

Your connector should now resemble the connector in the picture below.



## Compact Weather Station

Insert each contact pin until you feel a slight click. If you have inserted the contact into the incorrect hole it can be removed at this point by simply pulling it out. Please note there will be some resistance.

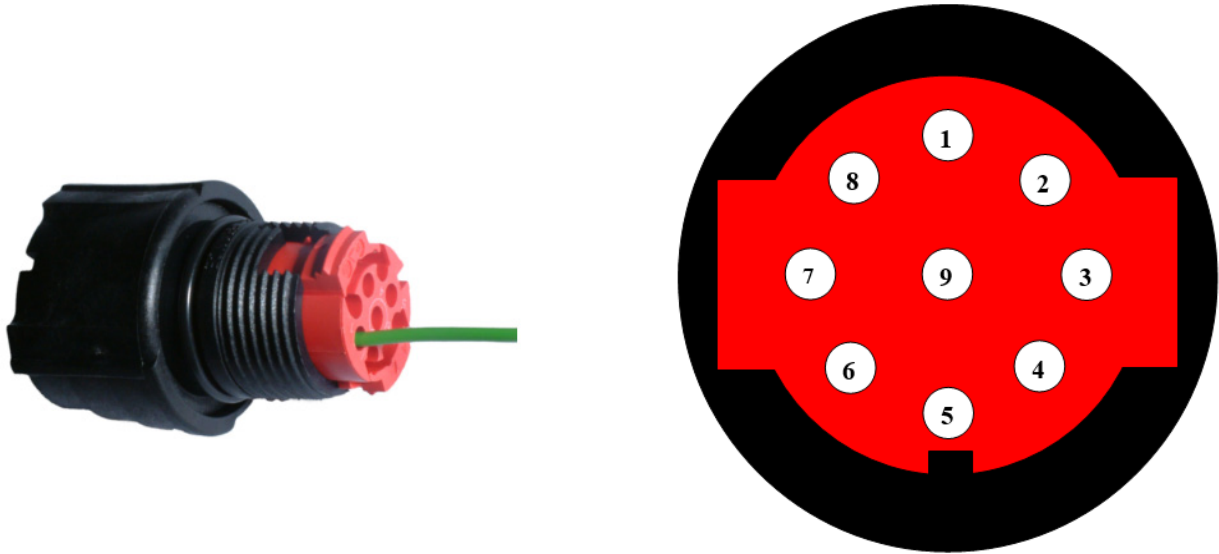

Rear View Connector

Continue to insert all of the contacts you require. Once all of the contacts are inserted push the red retainer into place.



Retainer can only be pushed back into place if the contacts are fully engaged.



Fit the connector to the MaxiMet so that you can finish assembling the connector



Screw the back shell onto the MaxiMet until it is fully in place. Please note that the final rotations can be slightly stiff



Now screw the next part of the connector into place



The connector can now be removed from the MaxiMet.



**To disassemble the connector, reverse this procedure.**

### Cabling

All MaxiMets have five output communication connection options:

- USB (using the 1.8m MaxiMet RS232 to USB cable, Part No. 1957-10-065)
- RS232
- RS422
- RS485 (Gill ASCII, two wire point to point) Modbus two wire networkable.
- SDI-12

MaxiMets GMX550 and GMX551 have a rain gauge contact closure input. For details see Appendix A. Technical Specification on page 45.



It is important that the cable is appropriate for the chosen communication network. The following sections describe the recommended types and maximum lengths of cable in each case.

### Cable Type

#### Digital Communications

<b>Wire type:</b>	24 AWG
<b>Wire size:</b>	7x32 AWG.
<b>Cable outer diameter:</b>	6-12mm (to match the connector gland).

For RS422/485 operation the cable should have twisted pairs with drain wire, screened with aluminised tape, with an overall PVC sheath. Typical wire size 7/0.2mm (24 AWG).

The table below shows an example manufacturers' reference; other manufacturers' equivalents can be used.

## Compact Weather Station

### Tipping Bucket

**Wire type:**

24 AWG (to fit MaxiMet GMX550/551, 4-way M8 connector)

**Cable outer diameter:**

3.5mm to 5mm (to match the connector gland)

### Recommended cable types

Application	No. of Pairs	24 AWG Gill Ref.	24 AWG Belden Ref.	24 AWG Batt Electronics Ref.
SDI-12 +Power	2	-	9729	-
Digital RS232 or RS485 2 wire + Power	3	026-02660	9730	91030
Digital RS422 + Power	4	026-03156	9728	91199
Tipping Bucket	1-2	See above	NA	NA

### Cable Length

The maximum cable length is dependent on the chosen communication method.

The following table shows the maximum cable lengths for the supported communication protocols at the given baud rates, using the recommended cable. If any problems of data corruption etc. are experienced, then a slower baud rate should be used. Alternatively, a higher specification cable can be tried.

### Suggested maximum cable lengths for supported communication networks

Communication format	Baud rate	Max. cable length
RS232	19200	6.5m
RS422/RS485	19200	1000m
SDI-12	1200	90M
GMX550/551	Max. cable length	
Contact switch closure	Switch resistance plus there and back cable resistance to be less than 20 ohms.	

## Compact Weather Station

### Heater Voltage

Please note that when the heater function is set to ON/AUTO, cable voltage drop will need to be considered. The recommended Gill/Belden cable conductor has a resistance of 28.8Ω/1000ft or 304.8m, 94mΩ per m.

For example, if using a 10m cable, then this would equate to 20m of power conductor (power plus ground return).

Cable resistance is  $20 \times 0.094 = 1.880\Omega$ .

The voltage drop due to the external cable is dependent on the current drawn, not the power supply voltage

Current Draw	Voltage Drop, 10m Cable
10mA	0.0188V
100mA	0.188V
1000mA	1.880V

However, the higher the voltage the higher the current drawn.

This voltage drop will result in the voltage reported by the unit being lower than that supplied to the cable.

### Connections

Any cable wires not used should be isolated and grounded at the terminating equipment/user end. Digital 0V should be used in conjunction with RS422 Tx/Rx lines in order to improve noise immunity.

### Appendix D. Configuring MaxiMet with MetSet

Install MetSet software (V2.19 or higher) on to a PC from the Gill website at:

<http://gillinstruments.com/main/software.html>

Before you use MetSet check that MaxiMet is correctly connected to a serial COM port or USB COM port on your PC (maximum COM port number accepted by MetSet is 50).

The optional Gill 1.8m, RS232 to USB cable (Gill Part No. 1957-PK-073) can be used to power and provide a suitable communication link for configuring a MaxiMet unit.



MetSet is compatible with RS232 and RS422 connected units with ASCII and NMEA outputs only. Use Safe Mode if connected to units set for SDI-12 or Modbus outputs to read/change settings.

**The availability of certain functions and parameters illustrated will depend on the MaxiMet model and Options see 2.1 on page 7, 2.2 on page 8, and for Parameter details, Appendix N on page 180.**

### Opening MetSet

Click on the MetSet button on your PC's desktop or choose **Start > All Programs > MetSet > MetSet**

The MetSet Control Centre window is displayed. If you have more than one MaxiMet connected to your PC, MetSet, by default, selects the first device detected.

For most applications it is recommended to click on the MetSet **Connect and Read** button.

MetSet interrogates the MaxiMet and returns a summary of the device settings. Depending on the MaxiMet sensor connected only settings and parameters appropriate to the connected MaxiMet unit will be shown.

MetSet Configuration Software v2.17-01

Device Name	Status
MaxiMet	ONLINE
MetConnect	ONLINE
MetPak	OFFLINE

## Compact Weather Station



MetSet also saves a copy of the screen below as a Session Report File that can be accessed at the following destination: C:\GillAppsData\Metset\SessionReports.

Example Summary of MaxiMet Device Settings

```
GILL Summary of Device Settings
SETTINGS ARE AS FOLLOWS:

PROTOCOL : GILL
COMMS : RS232
(BAUD) : 19200
NODE : Q
OUTFREQ : 1HZ
MSGMODE : CONT
ASCTERM : CRLF
ECHO : ON
ALIGN : 0
SENSOR WIND : ON
UNITS WIND : MS
NODIR : 0.00
AVGSHORT : 60
AVGLONG : 10
PERGUST : 1
RAVGUST : 3
SENSOR COMPASS : ON
COMPASSDECL : +000.0
SENSOR TEMP : ON
UNITS TEMP : C
SENSOR DEWPOINT : ON
UNITS DEWPOINT : C
SENSOR PRESS : ON
UNITS PRESS : HPA
HASL : +00000.00
HASTN : +00000.00
SENSOR RH : ON
UNITS RH : %
REPORT : HEATSTAT
POWER : 0
TIME : 2024-01-22T15:47:39
TZOFFSET : +00.00
LAT : +51.480000
LONG : +000.000000
USERINF :
SENSOR TILT : ON
PUPMSG STATUS : ON
PUPMSG REPORT : ON
PUPMSG UNITS : ON
MODEBUS : RTU
MODADDR : 1
DATABITS : 8
STOPBITS : 1
PARITY : NONE
MODTERM : 10
MODICT : 1000
HEATING : OFF
HEATINGLOW : +05.00
HEATINGHIGH : +10.00

Note changes to ANEM, BAUD, COMMS or PROTOCOL settings
will take place after next power-up.
```

Close



Changes to BAUD, COMMS or PROTOCOL settings will take place after the next power-up. Click on the Close button to continue to the MetSet set up screen.

## Compact Weather Station

When connected correctly a MetSet editing screen is available to read configuration settings, change configuration settings, save MaxiMet configuration settings to a PC file location, upload MaxiMet configuration settings from a PC file and view the MaxiMet raw data string output

MetSet Editing Screen

MetSet Configuration Software v2.17-01

**GILL** **MetSet**

Comms | ASCII\_Setup | Wind | Compass\_GPS | Temperature | Pressure | Humidity | Reporting | System | Power Up | MODBUS | Heating

Protocol: GILL ⚠️  
 Interface: RS232 ⚠️  
 Baud Rate: 19200 ⚠️  
 Node ID: Q ?  
 Output rate: 1HZ ?  
 Message Mode: CONT ?

Write Settings | Read Settings  
 Load Setup | Save Setup  
 Backup Device Setup | Restore Device Setup  
 Main Menu | View Output  
 About MetSet

Source: Device	S/N: 23440049	ONLINE
MAXIMET GMX500-5B-8?D1		19200 COM6
		S/W ver: 2669-2.25.05
		Protocol ver: 6

Source of MetSet Data      Model Number      Serial Number      Connection

MaxiMet device setting options

Move mouse over exclamation or question marks to read setting comment

Return to opening MetSet screen

View MaxiMet raw data output string

### MetSet Connection Status Information

Reading	Function
<b>ONLINE</b>	ONLINE in green indicates the MaxiMet has been successfully connected to MetSet. OFFLINE in grey indicates that MetSet is being used without a MaxiMet in communication with MetSet.
4800 COM23	4800 is a report on the MaxiMet baud rate setting. COM 23 is a report on the MaxiMet COM port connection number.
S/W ver: 2669-2.00.25	2669 is the MaxiMet firmware number. 2.00.25 is the firmware revision.
Protocol ver: 4	4 is the protocol version (Gill internal reference).
Source: Device	MetSet reads 'Device' when the source of the data that MetSet has retrieved has come from the MaxiMet and the MaxiMet Model. MetSet reads 'File' when the source of data has come from a saved file. MetSet reports on the connected MaxiMet device (MAXIMET GMX600-1-000) and reads the unit Serial Number (S/N: 15410001)

### MetSet Online Settings



Online Mode Buttons	Function
Write Settings	MetSet configuration settings are saved to a connected MaxiMet.
Read Settings	MetSet retrieves the MaxiMet configuration settings
Load Setup	When selected MetSet retrieves a MetSet edit PC file and updates MetSet with these settings.
Save Setup	When selected MetSet edit settings are saved to a PC file location.
Back Up Device Setup	When selected the MaxiMet configuration settings are transferred to MetSet and then to a file location selected on a PC.
Restore Device Setup	When selected MetSet retrieves a MaxiMet configuration setting from a PC file, loads it into the MaxiMet and updates the MetSet edit settings.
View Output	Click on View Output to view the raw ASCII MaxiMet data string scrolling at the output rate. (View only feature). E.g.
Main Menu	Click here to go back to the opening MetSet screen

### MetSet Editing Pages



Items shown in bold are the default settings.

Comms	ASCII_Setup	Wind	Temperature	Pressure	Humidity	Precipitation	Reporting	PowerUp	MODBUS
-------	-------------	------	-------------	----------	----------	---------------	-----------	---------	--------

### Comms

Protocol	GILL	!
Interface	RS232	!
Baud Rate	19200	!
Node ID	Q	?
Output rate	1HZ	?
Message Mode	CONT	?

- Protocol: **GILL**, MODBUS or SDI-12  
(for SDI-12 also set MetSet Comms/Interface to SDI-12)
- Interface: **RS232**, RS422, RS485P2W (point to point) & SDI-12
- Baud Rate: 4800, 9600, **19200**, 38400 or 57600  
(1200 auto selected with SDI-12 setting)
- Node ID: A to P, **Q** to Z
- Output Rate: **1Hz (1 per second)**, once per minute, once per hour
- Message Mode: **CONT (continuous output)** or POLL (polled mode)



When Comms or Baud Rate settings are changed and saved to the device a warning is issued by MetSet. These setting changes will not become active until the MaxiMet Marine power is turned off and turned on again. The connecting device will then also need its Comms and Baud Rate settings changed to match the MaxiMet.

**When selecting Modbus, Message Mode must be set for CONT.**  
**Gill ASCII output is always fixed formatted for 8 Start bits, No Parity and 1 Stop bit.**  
**When the output rate is set to once per minute or once per hour, wind averaging is disabled.**

### ASCII Setup

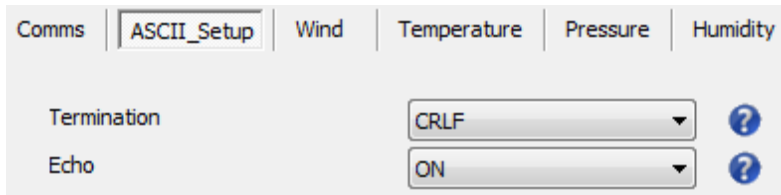

Termination: **CRLF** or CR  
Echo: **ON** or OFF

### Wind

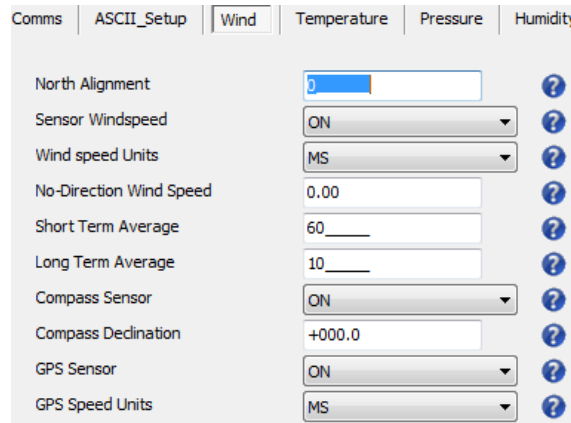

North Alignment: **0-359** degrees

Sensor Windspeed: **ON** or OFF

Wind Speed Units: **MS**, KTS, MPH, KPH, FPM  
(Metres/Second, Knots (Nautical Miles/Hour), Miles/Hour, Kilometres/Hour, Feet/Minute)

No-Direction Wind Speed: **0.00**m/s to 5.00m/s  
Wind speed above which direction readings are output.

Short Term Average: **60** (10-60)  
Configures WMO Short Term Average as the defined multiple of the output rate i.e. AVGSHORT 10 is a rolling average of the last ten outputs.

Long Term Average: **10** (1-10)  
Configures WMO Long Term Average as the defined multiple of the Short Term Average i.e. if AVGSHORT is 10 and AVGLONG is also 10, Long Term Average is a rolling average of the last 100 outputs.

Compass Sensor: **ON** or OFF  
With Compass Sensor ON, Wind Direction readings corrected to Magnetic North are output in the data string (CDIR). If set to OFF, the field with Compass Corrected Direction reading is left blank.

## Compact Weather Station

Compass Declination: **+000.0**

Magnetic declination is the angle between magnetic north and true north at a particular location on the Earth's surface. By convention, declination is positive when magnetic north is east of true north, and negative when it is to the west. This is a correction factor that is added to the Magnetic North heading from the compass. Map and declination figures in decimal figures can be obtained from:

- <http://www.geosats.com/magdecli.html>
- <http://www.ngdc.noaa.gov/geomag/declination.shtml>

GPS Sensor: **ON** or OFF (for GPS sensor output option units)  
GPS Speed Units: **MS**, KTS, MPH, KPH, FPM

### WMO Average Wind Reading Notes



WMO averaged wind readings are disabled in MaxiMet power saving mode. When the output rate is set to once per minute or once per hour, wind averaging is disabled.

The default output rate from MaxiMet is one new reading every second. In this case the WMO averaged wind reading result will be based on:

#### Long Term Average (1-10) × Short Term Average (10-60)

The direction and magnitude outputs are derived from the vector sum of U and V over the RWALONG averaging period (default 10 minutes with 1Hz output rate).

The gust output is derived from the vector sum of U and V over 3 readings (3 seconds with a 1 Hz output rate), and the max gust is the maximum of the gust value over the RWASHORT period (default 60 seconds with a 1Hz output rate). The max gust value is reset to zero at the end of each RWASHORT period.

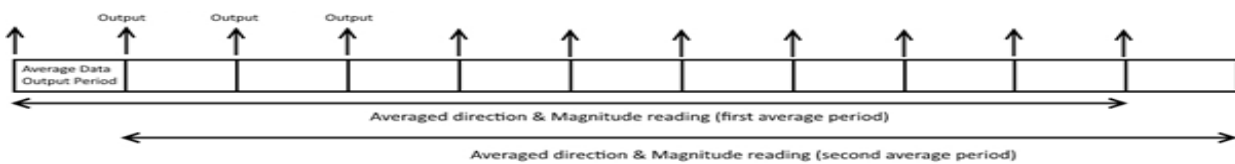

#### RWA Default Settings:

Output rate (Hz): 1  
RWASHORT: 60  
RWALONG: 10

Therefore, **MaxiMet output period** =  $60/1 = 60$  seconds (the MaxiMet will output a reading every 60 seconds).

**Averaged direction and magnitude reading** =  $10 \times 60 = 600$  seconds (this is the time the readings will be averaged over).

## Compact Weather Station

When the average building period has been completed, the average reported thereafter will be a rolling average derived from the last averaged direction and magnitude time period.

For instance, if a **2-minute averaged data** output was required set:

RWALONG: 2  
RWASHORT: 60

For these settings, every minute you would get an averaged output reading based on the previous 2 minutes of wind data.

For instance, if a **10-minute averaged data** output was required set:

RWALONG: 10  
RWASHORT: 60

For these settings, every minute you would get an averaged output reading based on the previous 10 minutes of wind data.

Whenever the unit is powered up then until the unit has reached its minimum long term averaging interval the Wind Status Code will read 0100 (Measurement Average Building).

If MaxiMet is in polled mode then when polled (default 1Hz output) MaxiMet will output the last valid 10-minute wind speed and direction average, updated every minute along with last valid 1 minute gust magnitude, due to default WMO settings.

In polled mode, the last set of computed WMO measurements shall be output on receipt of a poll request. Whilst a new WMO average is building, the last computed WMO average shall be output.

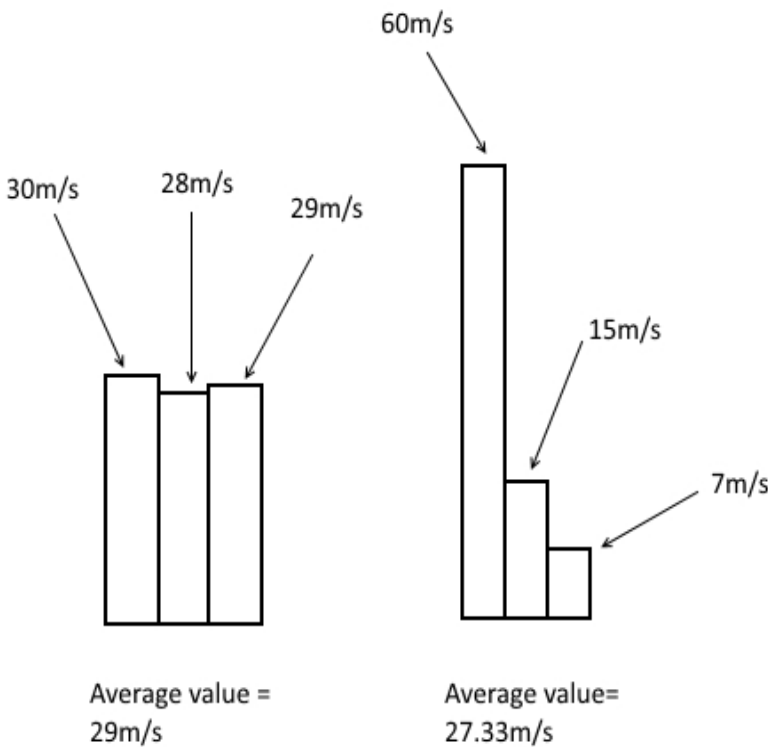

Two gust events are observed within one average data output period. The first produces an average value of 29m/s, the second an average value of 27.33m/s.

The event with the highest average value is the one that the MaxiMet will output, which in this case would be the average value from the first event, even though the peak gust was higher during the second event.

## Compact Weather Station

To enable WMO averaged Wind readings in the MaxiMet data string select the Reporting Tab/USERDEF and add new reporting field from the drop down menu called:

- AVGSPEED                    Outputs Average Speed readings
- AVGDIR                     Outputs Average Direction readings
- AVGCDIR                  Outputs Average Corrected Direction readings

The maximum Gust Speed is the magnitude of the maximum gust measured over the short term output period. Gust is generated from a rolling 3s average of the short term output period, and reset at the end of short term output period.

- GSPEED                    Outputs Maximum Wind Gust Speed

The maximum Gust Direction is the direction of the maximum gust measured over the short term output period. Gust is generated from a rolling 3s average of the short term output period, and reset at the end of short term output period.

- GDIR                        Outputs Maximum Wind Gust Direction

### Temperature

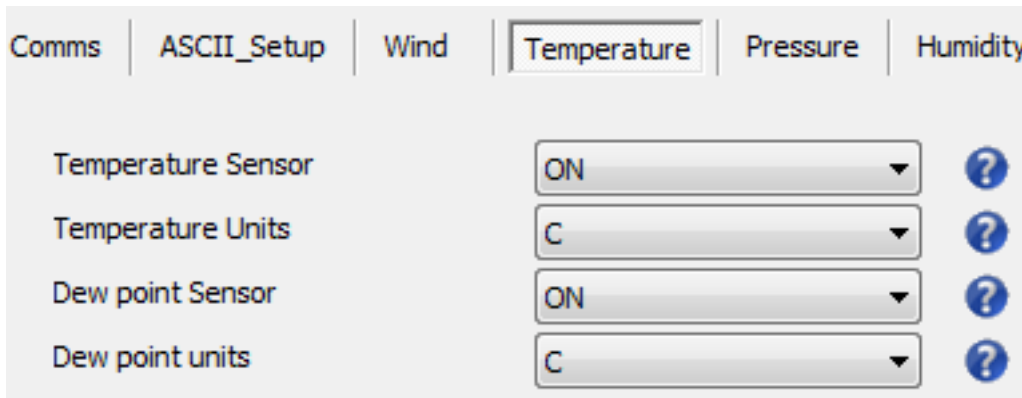

- Temperature Sensor:            **ON** or OFF
- Temperature Units:            **C**, K or F (Centigrade, Kelvin, Fahrenheit)
- Dew Point Sensor:            **ON** or OFF
- Dew Point Units:              **C**, K or F
- WBGT Sensor                  ON or **OFF**
- WBGT Units:                  **C**, K or F

### Pressure

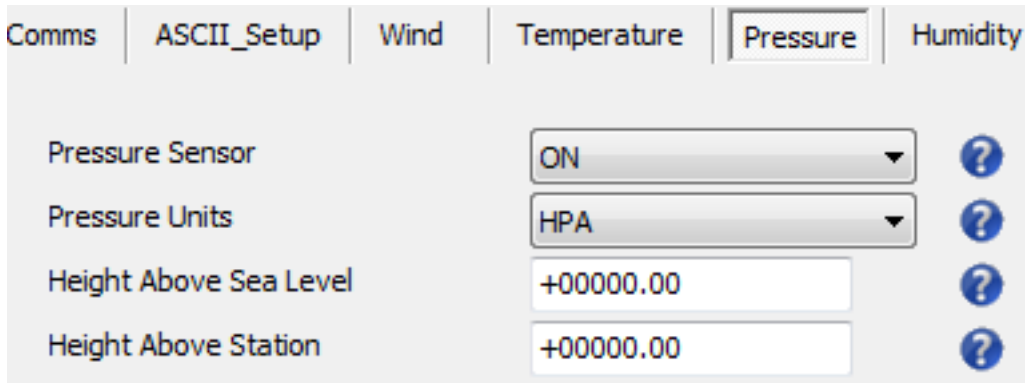

- Pressure Sensor: **ON** or OFF
- Pressure Units: **HPA**, MB, MMHG, INHG  
(Hectopascals, Millibars, Millimetres Mercury, Inches Mercury).
- Height Above Sea Level (HASL): **+00000.00** (0 to 10000 metres)

Elevation (on the ground) of the unit relative to the average sea level point.  
Atmospheric pressure varies with height above sea level as well as with atmospheric conditions. As the altitude at which the pressure sensor operates is usually constant (the station height), a correction is made to make the reading of the pressure sensor seem as if it were made at sea level. This means that the pressure reading has to be slightly increased from the value read by the MaxiMet sensor situated above sea level (often known as the station pressure).

- Height Above Station (HASTN): **+00000.00** (-100 to +100 Metres)  
The user can set the HASL figure together with the HASTN figure to allow pressure at sea level to be calculated.

### Humidity

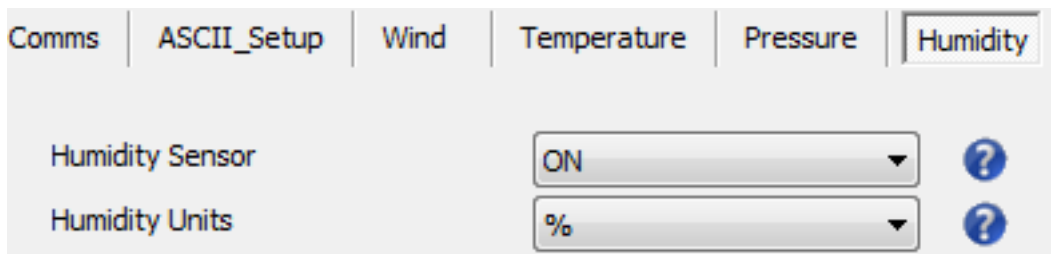

- Humidity Sensor: **ON** or OFF
- Humidity Units: **%**

### Precipitation

ASCII_Setup	Wind	Compass_GPS	Temperature	Pressure	Humidity	Precipitation	Reporting	System	Power Up	MODBUS	Heating
						Rain Sensor	ON	?			
						Precipitation Units	MM	?			
						Auto-reset Total Precipitation	ON	?			
						Rain gauge tip size	0.000	?			

Rain Sensor: **ON** or OFF  
Turns the rain sensor on or off.

Precipitation Units: **mm** or inches.

Auto-reset Total Precipitation: **ON** or OFF  
If set to ON the total precipitation value resets at midnight.  
If set to OFF the total precipitation value continues to accumulate.

Rain gauge tip size: Sets the rain sensor tip size in mm.

### Reporting

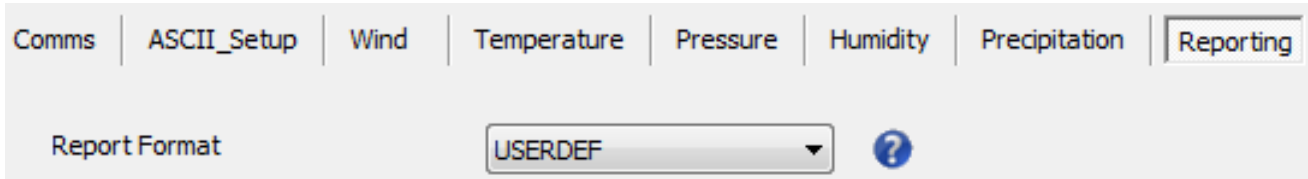

Report Format: **USERDEF**, DEFAULT, FULL or NMEA

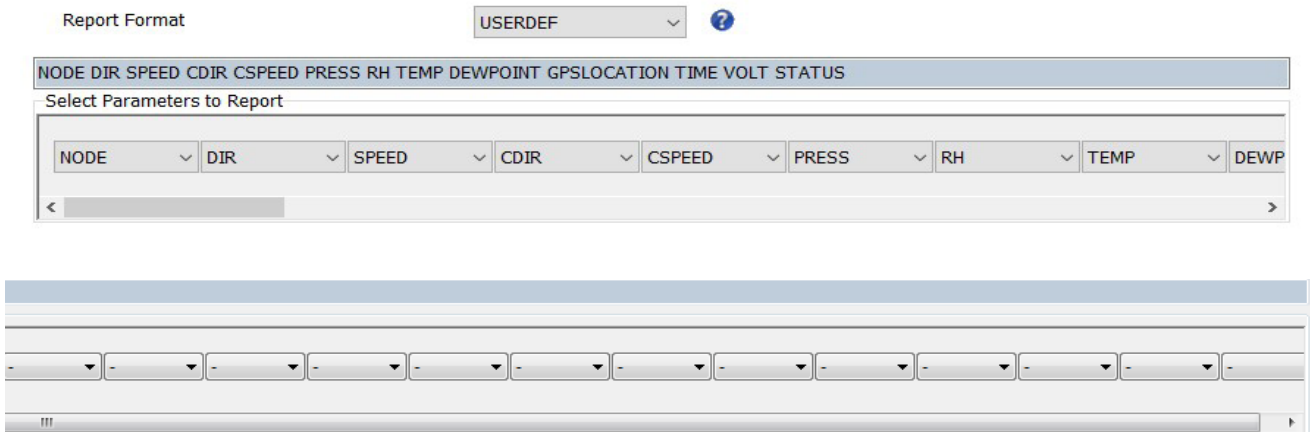

Select Parameters to Report using the dropdown selector boxes.

- DEFAULT Sets the unit to report the factory set output parameters
- FULL Sets the unit to output every available sensor and derived parameter output
- NMEA Sets the unit to output an NMEA data string
- USERDEF** Report parameters can be selected in any order or switched on or off in USERDEF setting  
See Appendix N on page 180 for a full list of all the parameters that can be configured. (Note that not all parameters are available on all models of MaxiMet.)

### System

Comms	ASCII_Setup	Wind	Temperature	Pressure	Humidity	Solar	Reporting	System
Power Mode	<input type="text" value="0"/>							
Date Time	<input type="text" value="2015-06-17T07:33:16"/>							
Update System time from GPS	<input type="text" value="ON"/>							
Time Offset	<input type="text" value="+00.00"/>							
Latitude	<input type="text" value="+50.758500"/>							
Longitude	<input type="text" value="-001.541900"/>							
User information	<input type="text" value="CAL DUE 15.08.17"/>							

Power Mode: **0** or 1

0 is the default normal power operation mode

1 is a power-saving mode and with this set then the unit will make one reading only at the output rate whether in polled mode or continuous mode. For lowest power set the unit for 1 output reading per hour.



**Power Saving Mode (1) is not applicable to NMEA, SDI-12 or Modbus outputs. In Power Saving Mode, Average Wind Data cannot be calculated.**

- Date Time: Set/read system Date/Time (YYYY-MM-DDTHH:MM:SS). See Appendix J p68 for more accurately setting Date/Time.
- Update System time from GPS: **ON/OFF**  
If a GPS unit is enabled, then UTC time is applied. Allow an hour for the GPS time to update after switching on.
- Time Offset: +00.00  
UTC time offset (range -24.00 to +24.00 hrs)
- Latitude: If using solar units for which Sunrise, Sunset and other related parameters are needed then enter the installation location Latitude.
- Longitude: If using solar units for which Sunrise, Sunset and other related parameters are needed then enter the installation location Longitude.
- User Information: Sets the User Information field shall have a maximum size of 16 characters, comprised of printable ASCII characters (to exclude "@", ",", "\*", "%" and "?").



Space character may be included. This field allows the user to, for instance, record installation or calibration dates, e.g. Cal due 15.08.24

### PowerUp

Comms	ASCII_Setup	Wind	Temperature	Pressure	Humidity	Precipitation	Reporting	System	PowerUp
Status Message Output	<input type="text" value="ON"/>								
Report Message Output	<input type="text" value="ON"/>								
Units Message Output	<input type="text" value="ON"/>								

Status Message Output: **ON** or OFF  
E.g. MAXIMET GMX501-3B-0000 2669 V2.00.24  
Reports MaxiMet Model details and Firmware version.

Report Message Output: **ON** or OFF  
E.g. NODE, DIR, SPEED, CDIR, PRESS, RH, TEMP, DEWPOINT, SOLARRAD, TIME, VOLT, STATUS, CHECK  
Reports data string output parameters and output order.

Units Message Output: **ON** or OFF  
E.g. -,DEG,MS,DEG,HPA,%,C,C,WM2,-,V,-,-  
<END OF STARTUP MESSAGE>  
Reports the output parameters units of measure.

### MODBUS

Comms	ASCII_Setup	Wind	Temperature	Pressure	Humidity	Precipitation	Reporting	System	PowerUp	MODBUS
Mode	<input type="text" value="RTU"/>									
Address	<input type="text" value="1"/>									
Data bits	<input type="text" value="8"/>									
Stop bits	<input type="text" value="1"/>									
Parity	<input type="text" value="NONE"/>									
Termination Char ASCII code	<input type="text" value="10"/>									
Inter-char timeout (ms)	<input type="text" value="1000"/>									

Mode: **RTU** or ASCII  
Address: **1** to 247  
Data Bits: **8 for Modbus RTU**, 7 for Modbus ASCII  
Stop Bits: **2 for No Parity**, 1 for Even/Odd Parity  
Parity: **NONE**, ODD, or EVEN  
Termination Char ASCII code: **10**, (0-255)  
Inter Char Timeout (mS): **1000** (500 to 10000)

### Heating

The **heating tab** can be used to change the **Heater Control Settings** used by MaxiMet.

#### Heater Mode

This setting selects the way the heater will work. The options are

- Off – this mode disables the heater until the heater setting is changed
- Normal – this mode switches the heater on based upon the ambient temperature as configured by the user.

#### Heating ON/OFF temperature Limits

- The heating on temperature limit should be set to the temperature at which the heater will switch on.
- The heating off temperature limit should be set to the temperature at which the heater will switch off.

MetSet Configuration Software v2.17-01

# GILL

# MetSet

Wind	Compass_GPS	Temperature	Pressure	Humidity	Precipitation	Reporting	System	Power Up	MODBUS	Heating	◀ ▶
Heater Mode	<input type="text" value="OFF"/>		?								
Heating on temperature	<input type="text" value="+05.00"/>		?								
Heating off temperature	<input type="text" value="+10.00"/>		?								



**Warning: Hot Surface.** When heating is activated, the heated ultrasonic transducers will get very hot and should not be touched.

### Polled Mode

Configuration for Polled Mode (MaxiMet Set for Power Mode 0)

To configure a MaxiMet unit for polled mode:

1. Connect a default-set MaxiMet to a PC as described in Section 5.5.
2. Open MetSet as described on Appendix D on page 91.
3. Click on the Edit Comms page:-
  - a. Set Protocol for required poll mode interface e.g. RS485.
  - b. Set Message Mode to Poll.
4. Click on Save Settings to Device on the Online Mode Menu.
5. Shut down the MaxiMet unit.
6. Change the hardware connections for the required poll mode interface.

### Data Retrieval in Polled Mode (MaxiMet Set for Power Mode 0)

The measurement rate shall always be 1Hz (i.e. regardless of the selected output rate or polling rate).

The configured measurement string shall be output in response to a measurement request ("`<network node address>`") from the user.

E.g. Q (where Q is the default MaxiMet identifier, range A-Z).

When the user issues a poll measurement request, the last computed set of 1 Hz measurement shall be output.

Response time to a poll shall be less than 570 milliseconds but note that parameters that require GPS may not be readily available until satellite fix has been achieved.

### Appendix E. Configuring MaxiMet for SDI-12

To configure a MaxiMet unit for SDI-12:

1. Connect a default-set MaxiMet to a PC as described in section 5.5.
2. Open MetSet as described in Appendix D on page 91.
3. Click on the Edit Comms page: -
  - a. Set Protocol for SDI-12.
  - b. Set Interface for SDI-12.No other settings changes are required.
4. Click on Save Settings to Device on the Online Mode Menu.
5. Shut down the MaxiMet unit.
6. Change the hardware connections for SDI-12 (see section 5.8 on page 39).
7. Power up the MaxiMet unit (**SDI-12 supply voltage 9.6V to 16V DC**). Allow 10 seconds for the unit to start up before sending an SDI-12 command.



When Protocol is set for SDI-12 mode it automatically sets the MaxiMet Baud Rate to 1200 baud irrespective of its Baud setting.

Only parameters mentioned below are available in SDI-12 Protocol mode irrespective of the Reporting page setting.



aM2! Command reports different parameters dependent on the firmware version of the sensor. (Refer to MetSet Connection Status Information on page 94 for details.)

### SDI-12 Units of Measure



Not all the following outputs are available and will depend on the MaxiMet variant, see 2.1 on page 7 and Appendix N on page 180.

**GMX Model SDI-12 Output Parameters**

Relative Wind Speed:	Metres per second (m/s)
Corrected Wind Speed:	Metres per second (m/s)
Average Relative Wind Speed	Metres per second (m/s)
Relative Gust Speed	Metres per second (m/s)
Relative Wind Direction:	Degrees (°)
Corrected Wind Direction:	Degrees (°)
Average Relative Wind Direction	Degrees (°)
Relative Gust Direction	Degrees (°)
Temperature:	Degrees Celsius (°C)
Relative Humidity:	Percent (%)
Dewpoint:	Degrees Celsius (°C)
Pressure:	Hectopascals (hPa)
Precipitation Intensity:	Millimetres per hour (mm/h)
Total Precipitation:	Millimetres (mm)
Wind Chill:	Degrees Celsius (°C)
Heat Index:	Degrees Celsius (°C)
Air Density:	Kilograms per metre cubed (kgm-3)
(Derived) Wet Bulb Temperature:	Degrees Celsius (°C)
Solar Radiation:	Watts per metre squared (W/m2)
Sunshine Hours:	Hours (h)
Sunrise:	Hours:Minutes (h:min)
Solar Noon:	Hours:Minutes (h:min)
Sunset:	Hours:Minutes (h:min)
Position of the Sun:	Degrees (°)
Twilight Civil:	Hours:Minutes (h:min)
Twilight Nautical:	Hours:Minutes (h:min)
Twilight Astronomical:	Hours:Minutes (h:min)
X Tilt:	Positive or Negative Degrees (°)
Y Tilt:	Positive or Negative Degrees (°)
Z Orientation:	1 or 0
Height above sea level:	Metres (m)
Latitude:	Degrees (positive values are N, negative are S)
Longitude:	Degrees (positive values are E, negative are W)
Date:	Years-Months-Days
Time:	Hours:Minutes:Seconds (h:min:s)
Status	4 Digit Sensor Status Code (e.g. 0000 for a no-fault condition)
Wet Bulb Temperature:	Degrees Celsius (°C)
Black Globe Temperature:	Degrees Celsius (°C)
Wet Bulb Globe Temperature:	Degrees Celsius (°C)
Derived Wet Bulb Globe Temperature:	Degrees Celsius (°C)

### SDI-12 Commands



For each of the available aMx! commands and the aC! command there exists an equivalent aMCx! and aCC! command that provides a 3 character CRC on the associated send data command (aD0!, aD1! ...) immediately before the <CR><LF> characters. The CRC is calculated as per the SDI-12 Standard.



Unavailable measurements shall be "padded", e.g.: +999.99.  
Note: Parameters in **red** will only be outputted for MaxiMet GMX552.

Command	Description	Response	Example
<b>?!</b>	Returns Unit address	a<CR><LF>	0<CR><LF>
<b>aAb!</b>	Change the unit address a = 0, the default b = the new address	b<CR><LF>	1<CR><LF>
<b>al!</b>	Unit identification	013GillInst <serial number><CR><LF>	013GillInst 00014490002<CR><LF>
<b>aM!</b>	Address, Relative Wind Direction, Relative Wind Speed, Corrected Wind Direction, Corrected Wind Speed (GPS option unit only), Status	attn<CR><LF>  a is unit identifier ttt is time in seconds n is number of data values Measurement command to retrieve a reading of the maximum time the MaxiMet will take to complete a measurement, have data ready and the number of data values.	00035<CR><LF>  0 is unit identifier 003 is 3s measurement 5 is the number of data readings (Direction, Speed, Corrected Direction and Corrected Speed)
aD0!	Retrieve a line of the above data.	<address><relative wind direction><relative wind speed><corrected wind direction><corrected wind speed><status><CR><LF>	0+220+000.01+218+999.99 +0000<CR><LF>
<b>aM1!</b>	Address, Temperature, Relative Humidity, Dewpoint, Pressure, Status, Wind Chill, Heat Index, Air Density, Wet Bulb Temperature (derived)	attn<CR><LF>	00029<CR><LF>
aD0!	Retrieve a line of the above data.	<address><temperature><relative humidity><dewpoint><pressure><status> <wind chill><CR><LF>	0+021.8+035 .1+005.7+1006.2+000 +999<CR><LF>
aD1!	Retrieve final part of the above data	<address><heat index><air density><wet bulb temperature><CR><LF>	0+999+1.2+013.0<CR><LF>

## Compact Weather Station

Command	Description	Response	Example
<b>aM2!</b>	Address, Relative Wind Direction, Relative Wind Speed, Status	attn<CR><LF>	00033<CR><LF>
aD0!	Retrieve a line of the above data	<address><dir><mag><status><CR><LF>	0+029+000.01+0000<CR><LF>
<b>aM2!</b>	Address, Compass heading, pitch, roll, status, <b>Wet Bulb Temperature, Black Globe Temperature, Wet Bulb Globe Temperature, Derived Wet Bulb Globe Temperature</b>	attn<CR><LF>	00034<CR><LF>
aD0!	Retrieve a line of the above data	<address><compassh><pitch><roll><status><wet bulb temperature><black globe temperature><CR><LF>	0+159+00.00+00.0+0000+016.0+020.5<CR><LF>
aD1!	Retrieve final part of the above data	<address><wet bulb globe temperature><derived wet bulb globe temperature><CR><LF>	0+017.4+015.2<CR><LF>
<b>aM3!</b>	Address, Precipitation Intensity, Total Precipitation, Status	attn<CR><LF>	00033<CR><LF>
aD0!	Retrieve a line of the above data.	<address><precipitation intensity><total precipitation><status><CR><LF>	0+002.100+123.100+0000<CR><LF>
<b>aM4!</b>	Address, Solar Radiation, Sunshine Hours, X Tilt, Y Tilt, Z Orientation, Status	attn<CR><LF>	00026<CR><LF>
aD0!	Retrieve a line of the above data.	<address><solar radiation><sunshine hours><x-tilt><y-tilt><z-orientation><status><CR><LF>	0+0001+00.00+02-05+1+0000<CR><LF>
<b>aM5!</b>	Address, signed Latitude integer part, signed Latitude fractional part, signed Longitude integer part, signed Longitude fractional part, Height Above Mean Sea Level, Status	attn<CR><LF>	00026<CR><LF>
aD0!	Retrieve a line of the above data.	<address><signed latitude integer part><signed latitude fractional part><signed longitude integer part><signed longitude fractional part><height above mean sea level><status> <CR><LF>	0+50+763052-001539920+00000.90+0000<CR><LF>
<b>aM6!</b>	Address, Year, Month, Day, Hour, Minute, Second, Status	attn<CR><LF>	00027<CR><LF>

Command	Description	Response	Example
aD0!	Retrieve a line of the above data.	<address><year><month> <day><hour><minute> <second><status> <CR><LF>	0+2015+06+15 +14+07 +52+0000 <CR><LF>
<b>aM7!</b>	Address, Sunrise Time, Solar Noon Time, Sunset Time, Position of the Sun (Azimuth), Position of the Sun (Elevation), Twilight (Civil), Twilight (Nautical), Twilight (Astronomical), Status	atttn<CR><LF>	00039<CR><LF>
aD0!	Retrieve part of the above data.	<address><sunrise time><solar noon time><sunset time><position of the sun (azimuth)><position of the sun (elevation)><twilight (civil)><twilight (nautical)><CR><LF>	0+0515+1152+1829 +115+27+1908 +1950<CR><LF>
aD1!	Retrieve final part of the above data	<address><twilight (astronomical)><status> <CR><LF>	0+2034+0000 <CR><LF>
<b>aM8!</b>	Address, Relative Average Wind Direction, Relative Average Wind Speed, Relative Gust Wind Direction, Relative Gust Wind Speed, Units 1=ms, 2=kph, 3=mph, 4=knots, 5=fpm, Status	Atttn<CR><LF>	00036<CR><LF>
aD0!	Retrieve a line of the above data.	<address><relative Average Wind Direction (0-359)><Relative Average Wind Speed (units as set by aXUn! command)><Relative Gust Wind Direction (0-359)><Relative Gust Wind Speed (units as set by aXUn! command)><Units 1=ms, 2=kph, 3=mph, 4=knots, 5=fpm><Status><CR><LF>	0+323+000.05+310 +000.41+1 +0000<CR><LF>
<b>aM9!</b>	Averaged wind measurement with units set as m/s	Atttn<CR><LF>	00037<CR> <LF>
aD0!	Retrieve a line of the above data.	<address><relative Average Wind Direction (0-359)><Relative Average Wind Speed (m/s)><Relative Gust Wind Direction (0-359)><Relative Gust Wind Speed (m/s)> <Average Corrected Wind Direction (m/s)><Average Corrected Wind Speed (m/s)><CR><LF>	0+071+000.15+076 +000.25+290 +000.17 <CR><LF>

Command	Description	Response	Example
aC!	Concurrent measurements grouped into primary measurements, time/location, average/gust, and derived.	atttnn<CR><LF>	000350<CR><LF>
aD0!	Retrieve a line of the above data. (primary measurements)	<address><relative direction><relative wind speed><corrected direction><corrected wind speed><temp><relative humidity><pressure><precipitation intensity><solar radiation><CR><LF>	0+286+000.03 +296+000.08+022.2 +055+1001.4 +000.000+0002 <CR><LF>
aD1!	Retrieve a line of the above data. (primary measurements)	<address><x-tilt><y-tilt><z-orientation><volt><wet bulb temperature><black globe temperature><wet bulb globe temperature><derived wet bulb globe temperature><CR><LF>	0+00 01+1 +9999.99 +9999.99 +9999.99+11.8+16.0 +020.5+017.4+015.2 <CR><LF>
aD2!	Retrieve a line of the above data. (time/location)	<address><date year><date month><date day><time hour><time minute><time second><gps latitude integer><gps latitude fraction><gps longitude integer><gps longitude fraction><gps height above sea level><CR><LF>	0+2020+01 +30+13+19+37 +50+763148-001 -540111-0001.10 <CR><LF>
aD3!	Retrieve a line of the above data. (average/gust)	<address><wmo average direction><wmo average wind speed><wmo relative gust direction><wmo relative gust wind speed><wmo average wind speed units><wmo relative gust wind speed units><Units 1=ms, 2=kph, 3=mph, 4=knots, 5=fpm><wmo average corrected direction>< wmo average corrected windspeed><CR><LF>	0+323+000.05 +310+000.41 +1+0000 <CR><LF>
aD4!	Retrieve a line of the above data. (derived)	<address><wind chill><heat index><air density><wet bulb temperature><dew point><precipitation total><solar hours><CR><LF>	0+999+999 +1.2+016.3+012.7 +0000.000 +00.00 <CR><LF>

Command	Description	Response	Example
aD5!	Retrieve a line of the above data. (derived)	<address><sunrise><solar noon><sunset><sun position azimuth><sun position elevation><twilight civil><twilight nautical><twilight astronomical><status><CR><LF>	0+0745+1218 +1652+220+12 +1727+1807+ 1846+0004 <CR><LF>
aD6!	Retrieve a line of the above data.	<address><compassh><pitch><roll><status><CR><LF>	0+159+00.00 +00.0+0000 <CR><LF>
<b>aXU1!</b>	set measurement units for aM8! to m/s	aUM/S<CR><LF>	0UM/S<CR><LF>
<b>aXU2!</b>	set measurement units for aM8! to kph	aUKPH<CR><LF>	0UKPH<CR><LF>
<b>aXU3!</b>	set measurement units for aM8! to mph	aUMPH<CR><LF>	0UMPH<CR><LF>
<b>aXU4!</b>	set measurement units for aM8! to knots	aUKTS<CR><LF>	0UKTS<CR><LF>
<b>aXU5!</b>	set measurement units for aM8! to feet per minute	aUFPM<CR><LF>	0UFPM<CR><LF>
<b>aXA1mm!</b>	set long term averaging period (mm=minutes, 01-60).	aA1<CR><LF>	0A1<CR><LF>
<b>aXG1ss!</b>	set period for gust speed and direction rolling average (ss=01-10 seconds)	aG1<CR><LF>	0G1<CR><LF>
<b>aXG2mm!</b>	set period of gust would be reported (mm = 01-60), where mm is the number of short term average periods.	aG2<CR><LF>	0G2<CR><LF>

### Appendix F. Configuring MaxiMet for Modbus

#### MaxiMet Supported Modbus Specification

Modbus	RTU or ASCII
Baud Rate	9600 or 19200 Baud
COMMS	RS232 point to point only, RS485 2 wire networkable

#### Modbus Parameters

Parameter	Modbus ASCII		Modbus RTU	
Character	ASCII 0 to 9 and A to F (Hex)		Binary 0 to 255	
Error Check	Longitudinal Redundancy Check (LRC)		Cyclic Redundancy Check (CRC)	
Frame Start	Character ':' (3A Hex)		3.5 Characters Silence	
Frame End	Characters CR/LF (0D/0A Hex)		3.5 Characters Silence	
Gaps in Message	1 Second		1.5 Times Character Length	
Start Bit	1		1	
Data Bits	7		8	
Parity	Even/Odd	None	Even/Odd	None
Stop Bits	1	2	1	2

- Read Holding Registers function code is 0x03
- Diagnostics 0x08
- Get Comm event counter 0x0B
- Report slave/server ID 0x11

**Requires:** MaxiMet  
MetSet Software

1. Connect a MaxiMet to a PC COM port (default communication is RS232).
2. Open Gill MetSet Software.
3. Click on Connect and Read to reach the editing pages as shown below.

## Compact Weather Station

### 1. Select the Modbus page

Mode:	Choose between RTU and ASCII, in this case RTU
Address:	Choose a MaxiMet address number between 1 to 247
Data Bits:	Choose 7 for Modbus ASCII and 8 for Modbus RTU
Stop Bits:	Choose 1 for Even/Odd Parity or 2 for No Parity (None)
Parity:	Choose Even/Odd or None
Termination Char ASCII code:	Choose between 0-255
Inter Char Timeout (ms):	Choose 500ms - 10000ms

### 2. Select the COMMS Page

Protocol: Default is Gill	Select Modbus
Interface: Default is RS232	Select RS232 or RS4852W RS232 will only allow a single point to point non multi drop network connection. RS485 2 wire will allow networking with up to 32 connected devices.
Baud Rate: Default is 19200	Select required Baud Rate (9600 or 19200 supported)
Node ID: Default is Q	Not used for Modbus
Output Rate: Default is 1Hz	Set update rate for MaxiMet Data
<b>Message Mode: Default is CONT</b>	Ensure that the setting is CONT mode; Message Mode POLL is not applicable for Modbus use.

### 3. When required settings have been selected click on Write Settings

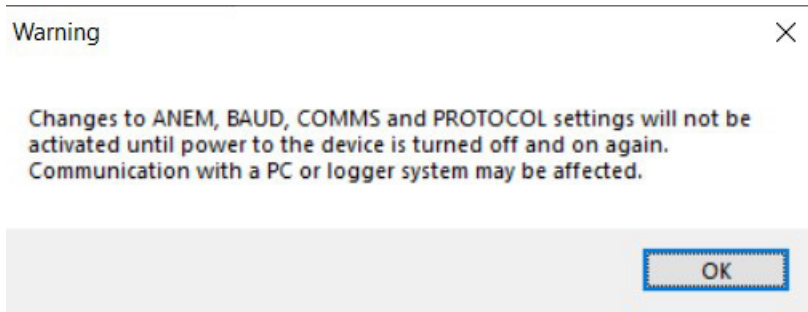

### 4. Click on Yes and then OK.



### 5. Power down the MaxiMet and apply power back to the MaxiMet to complete setting changes.



Now that the unit is in Modbus mode if any further changes need to be made use the SAFE MODE connection and method to re-establish communication with MetSet (See Appendix H on page 140).

### Taking Measurements in Modbus Mode

1. To work out Modbus register numbers applicable to a MaxiMet parameter, start out with setting up the MaxiMet in ASCII mode and determining which parameters are to be output, and the exact order that they are to be output before setting to Modbus Comms.
2. Refer to the Modbus output parameter table below to determine how many registers each chosen parameter will take up.
3. Fill up the register table, starting at 40001, with the required output parameters in the order in which they will be output.



After powering up the MaxiMet, wait 10 seconds before requesting any measurements.

### Summary of Modbus output parameters

Description	Parameter Code	Type	No. of Registers
Node	NODE	4-bit Character String	2
Wind speed	SPEED	32-bit Floating Point Value	2
Corrected wind speed	CSPEED	32-bit Floating Point Value	2
Gust speed	GSPEED	32-bit Floating Point Value	2
Corrected gust speed	CGSPEED	32-bit Floating Point Value	2
Average speed	AVGSPEED	32-bit Floating Point Value	2
Average corrected speed	AVGCSPEED	32-bit Floating Point Value	2
Wind Direction	DIR	32-bit Floating Point Value	2
Corrected Direction	CDIR	32-bit Floating Point Value	2
Gust Direction	GDIR	32-bit Floating Point Value	2
Corrected Gust Direction	CGDIR	32-bit Floating Point Value	2
Average Direction	AVGDIR	32-bit Floating Point Value	2
Average Corrected Direction	AVGCDIR	32-bit Floating Point Value	2
Pressure	PRESS	32-bit Floating Point Value	2
Pressure at Sea Level	PASL	32-bit Floating Point Value	2
Pressure at Station	PSTN	32-bit Floating Point Value	2
Relative Humidity	RH	32-bit Floating Point Value	2
Absolute Humidity	AH	32-bit Floating Point Value	2
Temperature	TEMP	32-bit Floating Point Value	2
Dewpoint	DEWPOINT	32-bit Floating Point Value	2
Precipitation Total	PRECIPT	32-bit Floating Point Value	2
Precipitation Intensity	PRECIPI	32-bit Floating Point Value	2
Precipitation Status	PRECIPS	4-bit Character String	2
Solar Radiation	SOLARRAD	32-bit Floating Point Value	2

Description	Parameter Code	Type	No. of Registers
Sunshine Hours	SOLARHOURS	32-bit Floating Point Value	2
Wind Chill	WCHILL	32-bit Floating Point Value	2
Heat Index	HEATIDX	32-bit Floating Point Value	2
Air Density	AIRDENS	32-bit Floating Point Value	2
Wet Bulb Temperature (derived)	WBTEMP	32-bit Floating Point Value	2
Sunrise	SUNR	32-bit Floating Point Value	2
Solar Noon Time	SNOON	32-bit Floating Point Value	2
Sunset	SUNS	32-bit Floating Point Value	2
Position of the sun - Azimuth	SUNP	32-bit Floating Point Value	2
Position of the sun - Elevation		32-bit Floating Point Value	2
Twilight Civil	TWIC	32-bit Floating Point Value	2
Twilight Nautical	TWIN	32-bit Floating Point Value	2
Twilight Astronomical	TWIA	32-bit Floating Point Value	2
X Tilt	XTILT	32-bit Floating Point Value	2
Y Tilt	YTILT	32-bit Floating Point Value	2
Z Orientation	ZORIENT	32-bit Floating Point Value	2
Compass Heading	COMPASSH	32-bit Floating Point Value	2
GPS Enabled Heading	GPSHEADING	32-bit Floating Point Value	2
GPS Speed over Ground	GPSSPEED	32-bit Floating Point Value	2
GPS Latitude	GPSLOCATION	32-bit Floating Point Value	2
GPS Longitude		32-bit Floating Point Value	2
GPS Height		32-bit Floating Point Value	2
GPS Location Fix and number of satellites	GPSSTATUS	4-bit Character String	2

Description	Parameter Code	Type	No. of Registers
Wet Bulb Temperature (external)	WWBT	32-bit Floating Point Value	2
Black Globe Temperature	BGT	32-bit Floating Point Value	2
Wet Bulb Globe Temperature	WBGTT	32-bit Floating Point Value	2
Wet Bulb Globe Temperature (derived)	WBGTD	32-bit Floating Point Value	2
Date	TIME	16 Byte Character String	8
Time		16 Byte Character String	8
Supply Voltage	VOLT	32-bit Floating Point Value	2
Heater Status	HEATSTAT	32-bit Unsigned Integer (UNIT)	2
System Status	STATUS	32-bit Unsigned Integer (UINT)	2
Wind Sensor Status	WINDSTAT	32-bit Unsigned Integer (UINT)	2
User Info Field	USERINF	16-bit Character String	8

- All registers are 16-bit. The first byte is high order and the second is low.
- Each measurement is comprised of two 16-bit registers.
  - For each register, the order of the two data bytes comprising the 16-bit register's value shall be: High Byte/Low Byte.
  - For each 32-bit data type (whether floating point or integer), the order of the first pair of bytes and last pair of bytes shall be: High Word/Low Word.
- Registers start at address 0.
- **Holding registers are available in the order of the MaxiMet data string which is configured using MetSet - see Appendix D on page 91.**
- For more information on how measurements are calculated see Appendix N on page 180.
- If measurements cannot be computed (i.e. a blank field in Gill mode output string/conditions for reporting Wind Chill/ Heat Index are not being met), their Holding Register contents shall be set to the Maximum Positive value (0x7FFFFFFF for 32-bit format data (both floating point and integer), and as 0x7FFF for 16-bit format data).

### GMX200 Modbus Default Setting Register Table

Register Type	Register Numbers	Value Type
4ch string	00-01	Node
32bit float	02-03	Direction
32bit float	04-05	Speed
32bit float	06-07	Corrected Direction
16ch string	08-15	Date
16ch string	16-23	Time
32bit float	24-25	Supply Voltage
32bit UINT	26-27	Status

### GMX200 with GPS Modbus Default Setting Register Table

Register Type	Register Numbers	Value Type
4ch string	00-01	Node
32bit float	02-03	Direction
32bit float	04-05	Speed
32bit float	06-07	Corrected Direction
32bit float	08-09	Corrected Speed
32bit float	10-11	GPS Latitude
32bit float	12-13	GPS Longitude
32bit float	14-15	GPS Height
16ch string	16-23	Date
16ch string	24-31	Time
32bit float	32-33	Supply Voltage
32bit UINT	34-35	Status

## GMX240 Modbus Default Setting Register Table

Register Type	Register Numbers	Value Type
4ch string	00-01	Node
32bit float	02-03	Direction
32bit float	04-05	Speed
32bit float	06-07	Corrected Direction
32bit float	08-09	Total Precipitation
32bit float	10-11	Precipitation Intensity
16ch string	12-19	Date
16ch string	20-27	Time
32bit float	28-29	Supply Voltage
32bit UINT	30-31	Status
32bit float	32-33	Supply Voltage
32bit UINT	34-35	Status

# Compact Weather Station

## GMX240 with GPS Modbus Default Setting Register Table

Register Type	Register Numbers	Value Type
4ch string	00-01	Node
32bit float	02-03	Direction
32bit float	04-05	Speed
32bit float	06-07	Corrected Direction
32bit float	08-09	Corrected Speed
32bit float	10-11	Total Precipitation
32bit float	12-13	Precipitation Intensity
32bit float	14-15	GPS Latitude
32bit float	16-17	GPS Longitude
32bit float	18-19	GPS Height
16ch string	20-27	Date
16ch string	28-35	Time
32bit float	36-37	Supply Voltage
32bit UINT	38-39	Status

## GMX300 Modbus Default Setting Register Table

Register Type	Register Numbers	Value Type
4ch string	00-01	Node
32bit float	02-03	Pressure
32bit float	04-05	Relative Humidity
32bit float	06-07	Temperature
32bit float	08-09	Dew point
16ch string	10-17	Date
16ch string	18-25	Time
32bit float	26-27	Supply Voltage
32bit UINT	28-29	Status

## GMX301 MODBUS Default Setting Register Table

Register Type	Register Numbers	Value Type
4ch string	00-01	Node
32bit float	02-03	Pressure
32bit float	04-05	Relative Humidity
32bit float	06-07	Temperature
32bit float	08-09	Dew point
32bit float	10-11	Solar Radiation
16ch string	12-19	Date
16ch string	20-27	Time
32bit float	28-29	Supply Voltage
32bit UINT	30-31	Status

## GMX500 Modbus Default Setting Register Table

Register Type	Register Numbers	Value Type
4ch string	00-01	Node
32bit float	02-03	Direction
32bit float	04-05	Speed
32bit float	06-07	Corrected Direction
32bit float	08-09	Pressure
32bit float	10-11	Relative Humidity
32bit float	12-13	Temperature
32bit float	14-15	Dew point
16ch string	16-23	Date
16ch string	24-31	Time
32bit float	32-33	Supply Voltage
32bit UINT	34-35	Status

## GMX500 with GPS Modbus Default Setting Register Table

Register Type	Register Numbers	Value Type
4ch string	00-01	Node
32bit float	02-03	Direction
32bit float	04-05	Speed
32bit float	06-07	Corrected Direction
32bit float	08-09	Corrected Speed
32bit float	10-11	Pressure
32bit float	12-13	Relative Humidity
32bit float	14-15	Temperature
32bit float	16-17	Dew point
32bit float	18-19	GPS Latitude
32bit float	20-21	GPS longitude
32bit float	22-23	GPS Height
16ch string	24-31	Date
16ch string	32-39	Time
32bit float	40-41	Supply Voltage
32bit UINT	42-43	Status

## GMX501 Modbus Default Setting Register Table

Register Type	Register Numbers	Value Type
4ch string	00-01	Node
32bit float	02-03	Direction
32bit float	04-05	Speed
32bit float	06-07	Corrected Direction
32bit float	08-09	Pressure
32bit float	10-11	Relative Humidity
32bit float	12-13	Temperature
32bit float	14-15	Dew point
32bit float	16-17	Solar Radiation
16ch string	18-25	Date
16ch string	26-33	Time
32bit float	34-35	Supply Voltage
32bit UINT	36-37	Status

### GMX501 with GPS Modbus Default Setting Register Table

Register Type	Register Numbers	Value Type
4ch string	00-01	Node
32bit float	02-03	Direction
32bit float	04-05	Speed
32bit float	06-07	Corrected Direction
32bit float	08-09	Corrected Speed
32bit float	10-11	Pressure
32bit float	12-13	Relative Humidity
32bit float	14-15	Temperature
32bit float	16-17	Dew point
32bit float	18-19	Solar Radiation
32bit float	20-21	GPS Latitude
32bit float	22-23	GPS longitude
32bit float	24-25	GPS Height
16ch string	26-33	Date
16ch string	34-41	Time
32bit float	42-43	Supply Voltage
32bit UINT	44-45	Status

## GMX551 Modbus Default Setting Register Table

Register Type	Register Numbers	Value Type
4ch string	00-01	Node
32bit float	02-03	Direction
32bit float	04-05	Speed
32bit float	06-07	Corrected Direction
32bit float	08-09	Pressure
32bit float	10-11	Relative Humidity
32bit float	12-13	Temperature
32bit float	14-15	Dewpoint
32bit float	16-17	Total Precipitation
32bit float	18-19	Precipitation Intensity
32bit float	20-21	Solar Radiation
16ch string	22-29	Date
16ch string	30-37	Time
32bit float	38-39	Supply Voltage
32bit UINT	40-41	Status

## GMX551 with GPS Modbus Default Setting Register Table

Register Type	Register Numbers	Value Type
4ch string	00-01	Node
32bit float	02-03	Direction
32bit float	04-05	Speed
32bit float	06-07	Corrected Direction
32bit float	08-09	Corrected Speed
32bit float	10-11	Pressure
32bit float	12-13	Relative Humidity
32bit float	14-15	Temperature
32bit float	16-17	Dewpoint
32bit float	18-19	Total Precipitation
32bit float	20-21	Precipitation Intensity
32bit float	22-23	Solar Radiation
32bit float	24-25	GPS Latitude
32bit float	26-27	GPS Longitude
32bit float	28-29	GPS Height
16ch string	30-37	Date
16ch string	38-45	Time
32bit float	46-47	Supply Voltage
32bit UINT	48-49	Status

## GMX552 Modbus Default Setting Register Table

Register Type	Register Numbers	Value Type
4ch string	00-01	Node
32bit float	02-03	Direction
32bit float	04-05	Speed
32bit float	06-07	Corrected Direction
32bit float	08-09	Pressure
32bit float	10-11	Relative Humidity
32bit float	12-13	Temperature
32bit float	14-15	Dew point
16ch string	16-23	Date
16ch string	24-31	Time
32bit float	32-33	Supply Voltage
32bit UINT	34-35	Status



The MaxiMet GMX552 does not report heat stress parameters by default. Users can add these parameters by using MetSet to configure the device.

### GMX552 with GPS Modbus Default Setting Register Table

Register Type	Register Numbers	Value Type
4ch string	00-01	Node
32bit float	02-03	Direction
32bit float	04-05	Speed
32bit float	06-07	Corrected Direction
32bit float	08-09	Corrected Speed
32bit float	10-11	Pressure
32bit float	12-13	Relative Humidity
32bit float	14-15	Temperature
32bit float	16-17	Dew point
32bit float	18-19	GPS Latitude
32bit float	20-21	GPS longitude
32bit float	22-23	GPS Height
16ch string	24-31	Date
16ch string	32-39	Time
32bit float	40-41	Supply Voltage
32bit UINT	42-43	Status



The MaxiMet GMX552 does not report heat stress parameters by default. Users can add these parameters by using MetSet to configure the device

## GMX550, GMX600 and GMX603 Modbus Default Setting Register Table

Register Type	Register Numbers	Value Type
4ch string	00-01	Node
32bit float	02-03	Direction
32bit float	04-05	Speed
32bit float	06-07	Corrected Direction
32bit float	08-09	Pressure
32bit float	10-11	Relative Humidity
32bit float	12-13	Temperature
32bit float	14-15	Dewpoint
32bit float	16-17	Total Precipitation
32bit float	18-19	Precipitation Intensity
16ch string	20-27	Date
16ch string	28-35	Time
32bit float	36-37	Supply Voltage
32bit UINT	38-39	Status

GMX550, GMX600 and GMX603 with GPS Modbus Default Setting Register Table

Register Type	Register Numbers	Value Type
4ch string	00-01	Node
32bit float	02-03	Direction
32bit float	04-05	Speed
32bit float	06-07	Corrected Direction
32bit float	08-09	Corrected Speed
32bit float	10-11	Pressure
32bit float	12-13	Relative Humidity
32bit float	14-15	Temperature
32bit float	16-17	Dewpoint
32bit float	18-19	Total Precipitation
32bit float	20-21	Precipitation Intensity
32bit float	22-23	GPS Latitude
32bit float	24-25	GPS Longitude
32bit float	26-27	GPS Height
16ch string	28-35	Date
16ch string	36-43	Time
32bit float	44-45	Supply Voltage
32bit UINT	46-47	Status

## Compact Weather Station

Simply Modbus program reading example, MaxiMet GMX550 or GMX600 default output Modbus data as follows

Simply Modbus 7.0 interface showing a Modbus read request for registers 40001 to 40039. The results table is as follows:

register #	bytes	results	notes
4chString	40001	0000 0051	Q
32bit Float	40003	4200 0000	32.00000
32bit Float	40005	4019 999A	2.4000001
32bit Float	40007	4367 0000	231.00000
32bit Float	40009	4480 9666	1028.7000
32bit Float	40011	4292 0000	73.00000
32bit Float	40013	410A 3D71	8.640000
32bit Float	40015	4087 0A3E	4.220000
32bit Float	40017	3F99 999A	1.2000000
32bit Float	40019	3F99 999A	1.2000000
16chString	40021	2020 2020	2015-03-04
16chString	40029	2020 2020	11:34:39.1
32bit Float	40037	418F 3333	17.900000
32bit UINT	40039	0000 0000	0

Simply Modbus program reading example, MaxiMet GMX550 or GMX600 with GPS default output Modbus data as follows:



Register data 40001 to 40006 will be as per the above example.

Simply Modbus 7.0 interface showing a Modbus read request for registers 40001 to 40035. The results table is as follows:

register #	bytes	results	notes
32bit Float	40007	447E C666	1019.1000
32bit Float	40009	4112 B852	9.170000
32bit Float	40011	4396 0000	300.00000
32bit Float	40013	3DB8 51EB	0.09000000
32bit Float	40015	0000 0000	0.0000000
32bit Float	40017	0000 0000	0.0000000
32bit Float	40019	424B 0D4D	50.76299
32bit Float	40021	BFC5 1D06	-1.539948E+0
32bit Float	40023	C126 6666	-1.040000E+1
32bit Float	40025	43A1 5852	322.6900
32bit Float	40027	0000 0000	0.0000000
32bit Float	40029	447E C666	1019.1000
32bit Float	40031	447E C666	1019.1000
32bit Float	40033	4298 0000	76.00000
32bit UINT	40035	0000 010B	267

### Appendix G. Configuring MaxiMet for NMEA 0183 Output

1. Connect a default set MaxiMet to a PC as described in para 5.5.
2. Open MetSet as described on Appendix D on page 91 and click on the Reporting page.
3. Change the Report Format drop down menu from USERDEF to NMEA.
4. On the Comms page select the required Interface, generally RS422.
5. On the Comms page select the required Baud Rate, normally 4800 baud (or sometimes 9600 baud).
6. Click on Save Settings to Device.



All measurement units are determined by the Gill ASCII output settings.

#### List of NMEA 0183 Output Sentences

In this section, the different NMEA 0183 sentences are presented, and the structure of each is explained. In these definitions, placeholders for variables and values are shown in *italic lower-case*, and these are explained in more detail below each sentence structure.

#### Relative Wind Sentence

`$WIMWV,ddd,R,sss.ss,u,v*cceol`

<code>\$WIMWV</code>	Wind Instrument Mean Wind direction and Velocity.
<code>ddd</code>	Wind Direction (e.g. 049).
<code>R</code>	Relative Wind measurement, wind speed and/or direction information, reported with respect to the MaxiMet North marker.
<code>sss.ss</code>	Wind Speed (e.g. 000.03).
<code>u</code>	N = Knots, M = m/s, S = mph, K = kph, F = fpm
<code>v</code>	Measurement validity: A = Acceptable, V = Void (fail).
<code>cc</code>	Hex Check Sum (e.g. 03).
<code>eol</code>	End-of-line characters (e.g. <CR><LF>)

#### Corrected Wind Sentence

`$WIMWV,ddd,T,sss.ss,u,v*cceol`

<code>\$WIMWV</code>	Wind Instrument Mean Wind direction and Velocity.
<code>ddd</code>	Wind Direction (e.g. 214).
<code>T</code>	True or Apparent Wind measurement, wind speed and/or direction information, corrected by a compass and GPS (option) to give accurate data regardless of where North marker is aligned.
<code>sss.ss</code>	Wind Speed only available if a GPS option is fitted (format e.g. 001.05).
<code>u</code>	N = Knots, M = m/s, S = mph, K = kph, F = fpm
<code>v</code>	Measurement validity: A = Acceptable, V = Void (fail).
<code>cc</code>	Hex Check Sum (e.g. 18).
<code>eol</code>	End-of-line characters (e.g. <CR><LF>)

## Compact Weather Station

### GPS Sentence

\$GPGGA,hhmmss.sss,tttt.tttt,N,ggggg.gggg,W,f,nn,d.d,±a.a,M,gg.g,M,,iiii\*cceol

\$GPGGA	NMEA GPS Protocol Header
hhmmss.sss	UTC Time hhmmss.sss (e.g. 095010.000)
tttt.tttt	Latitude ddm m.mmmm (e.g. 5045.8065)
N	North/South Indicator
ggggg.gggg	Longitude ddm m.mmmm (e.g. 00132.4003)
W	East/West indicator
f	Position Fix Indicator, e.g. 1 (see below)
nn	Satellites being used, e.g. 06 (Range 0-12)
d.d	Horizontal Dilution of Precision (e.g. 1.5)
±a.a	Mean Sea Level (NSL) Altitude in Metres (e.g. -3.0)
M	MSL Units, metres
gg.g	Geoid Separation
M	Geoid Separation units, metres
iiii	Differential GPS Reference Station ID (e.g. 0000)
cc	Checksum (e.g. 6C)
eol	End-of-line characters (e.g. <CR><LF>)

### Position Fix

Indicator Value	Description
0	Fix not available or invalid
1	GPS SPS Mode, fix valid
2	Differential GPS, SPS Mode, fix valid
3-5	Not supported
6	Dead Reckoning Mode, fix valid

### Tilt Sentence

\$PGILT,A,±xx,D,±yy,D,±z,TILT\*cceol

\$P	Start of sentence and proprietary sentence identifier
GIL	Gill Instruments recognised NMEA manufacturer mnemonic
T	Indicates TILT information
A	Type of Sensor (Angular Displacement)
±xx	+ve x-tilt indicates unit is tipping towards east <b>xx</b> degrees
D	Units (Degrees)
±yy	+ve y-tilt indicates unit is tipping towards north <b>yy</b> degrees
D	Units (Degrees)
±z	Z-orientation "+1" shall be reported if the unit is installed upright, or "-1" if facing downwards
TILT	Name of the Sensor
cc	Hex Check Sum (e.g. 18).
eol	End-of-line characters (e.g. <CR><LF>)

### Transducer Sentence

A transducer sentence may consist of one or more transducer data chunks:

\$WIXDR,<TRANSDUCER DATA>,<TRANSDUCER DATA>...<TRANSDUCER DATA>\*cceol

\$WIXDR	Wind Instrument Transducer
<TRANSDUCER DATA>	A transducer data chunk, see below
cc	Hex Check Sum (e.g. 18).
eol	End-of-line characters (e.g. <CR><LF>)

Each <TRANSDUCER DATA> chunk has the format

t,±vvv.v,u,mmmm

t	Type of output, see below
±vvv.v	Value of the sensor output
u	Units of the value, see below
mmmm	Name of the sensor or output, see below

GMX / NMEA Sentence	Sensor Name	Output type	Units
Precipitation	PRECIP	Y	M = mm/h
Temperature	TEMP	C	C = °C, F = °F, K = K
Dewpoint	DEWP	C	C = °C, F = °F, K = K
Barometric pressure	PRESS	P	B = bar, H = hPa, R = mbar, M = mmHg, I = inHg
Relative humidity	RH	H	P = %
Solar radiation	SOLAR	Z	W = W/m2

Examples:

\$WIXDR,Y,000.000,M,PRECIP\*77<CR><LF>

\$WIXDR,C,+023.0,C,TEMP,C,+008.1,C,DEWPP,1.0243,B,PRESS,H,038.1,P,RH,Z,0000,W,SOLAR\*01<CR><LF>

### Matrix of MaxiMet variants and available NMEA 01813 Output Sentences

The following matrix indicates which NMEA0183 sentences are reported for each MaxiMet variant. For each variant, all of the indicated sentences will be reported at the standard output rate, in the order shown in this matrix. For example, a MaxiMet GMX300 will report a Transducer Sentence containing Temperature, Dewpoint, Pressure and Relative humidity readings, followed by a Tilt sentence.

GMX / NMEA Sentence	Relative Wind	Corrected Wind	Transducer Sentence	GPS Sentence	Tilt Sentence
200				(GPS option only)	
240			PRECIP	(GPS option only)	
300			TEMP, DEWP, PRESS, RH		
301			TEMP, DEWP, PRESS, RH, SOLAR		
400			TEMP, DEWP, PRESS, RH, PRECIP		
500			TEMP, DEWP, PRESS, RH	(GPS option only)	
501			TEMP, DEWP, PRESS, RH, SOLAR	(GPS option only)	
550			TEMP, DEWP, PRESS, RH, PRECIP	(GPS option only)	
551			TEMP, DEWP, PRESS, RH, SOLAR, PRECIP	(GPS option only)	
552			TEMP, DEWP, PRESS, RH	(GPS option only)	
600			TEMP, DEWP, PRESS, RH, PRECIP	(GPS option only)	
603			TEMP, DEWP, PRESS, RH, PRECIP	(GPS option only)	

### Appendix H. Safe Mode

#### Summary

The MaxiMet Safe Mode provides a means of recovering communication with the MaxiMet whatever configuration setting may have been made. For instance, if the unit has been set for SDI-12 or Modbus operation Safe Mode can be used to change the communication option back to RS232 or RS422.

#### Safe Mode Method 1

##### Connection

1. Connect the MaxiMet for RS232 communication as detailed in para 5.5.
2. Open Gill MetSet Software (Appendix D on page 91).
3. Click on Connect and Read. MetSet will scan COM port settings for a connected MaxiMet but as the COMMS protocol is not matched will be unable initially to find the MaxiMet.
4. Now click on the Safe Mode button.

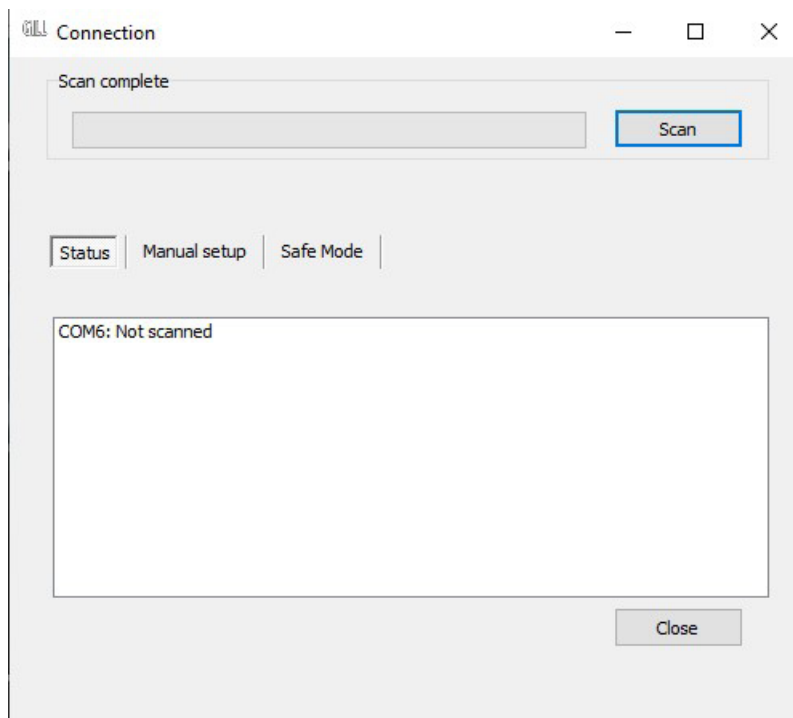

5. Ensure the MaxiMet is wired for RS232 operation and power and click on Next.

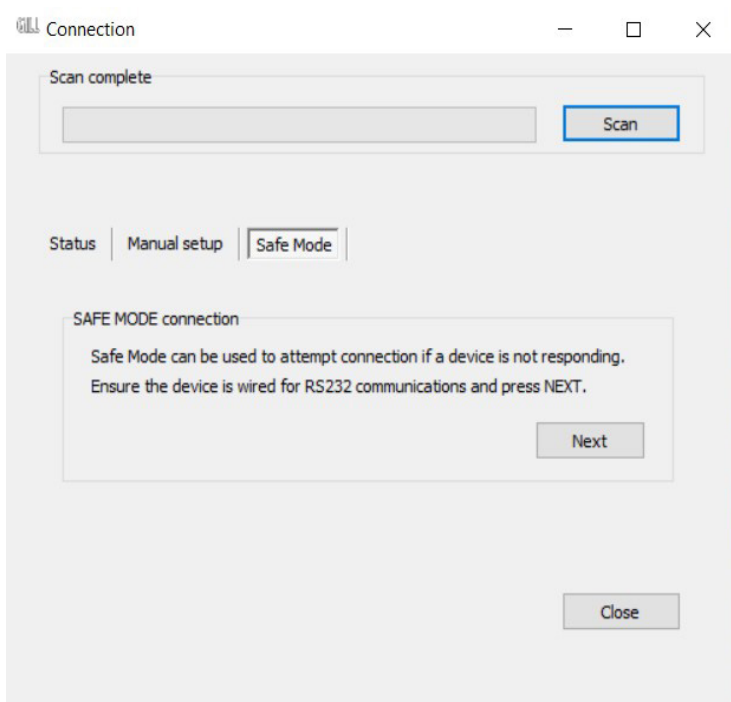

6. Enter the MaxiMet COM Port connection number.

**NOTE: Use dongle check box is only applicable when using a MetConnect device.**

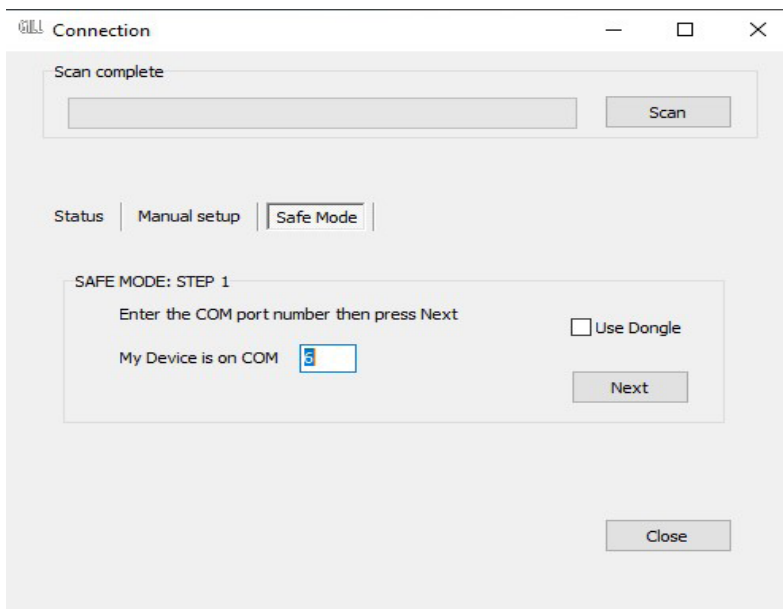

## Compact Weather Station

7. Ensure power is now disconnected from the MaxiMet.

**NOTE: If using the Gill Instruments RS232 to USB configuration cable then unplug the 9-way connector from the base of the MaxiMet.**

8. Now click on Next.

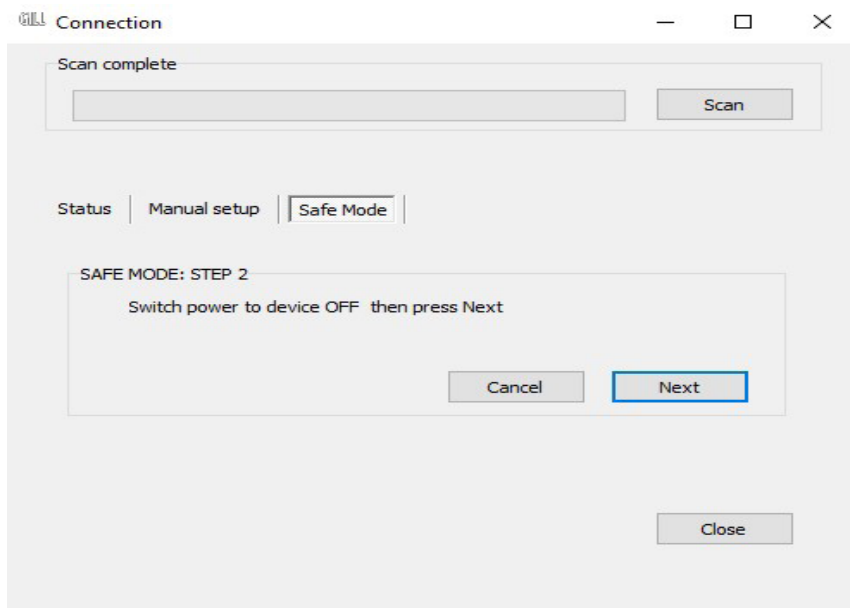

9. Re-connect power to the MaxiMet.

**NOTE: If using the Gill Instruments RS232 to USB configuration cable then plug in the 9-way connector to the base of the MaxiMet.**

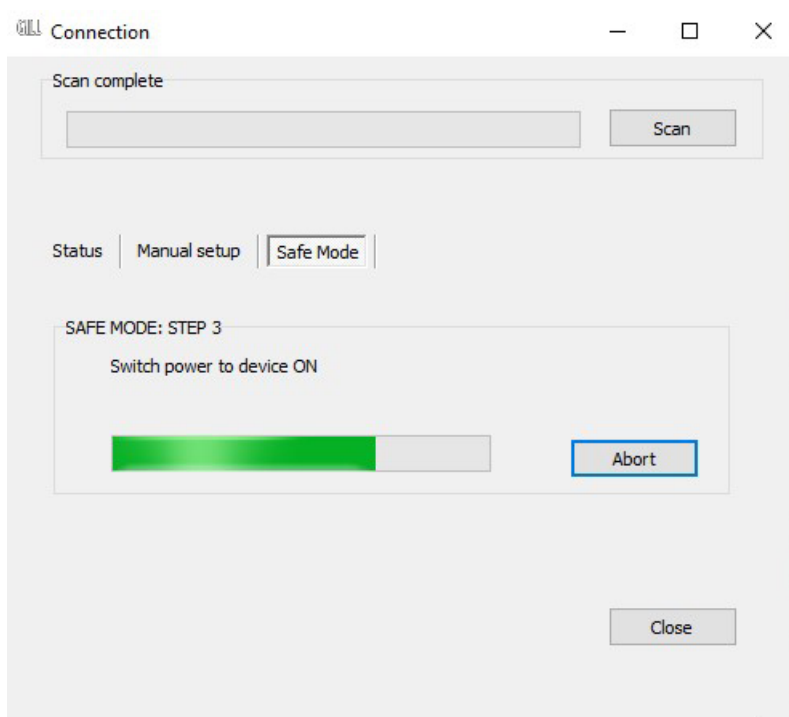

10. Device will now connect and display a Summary of Device settings.

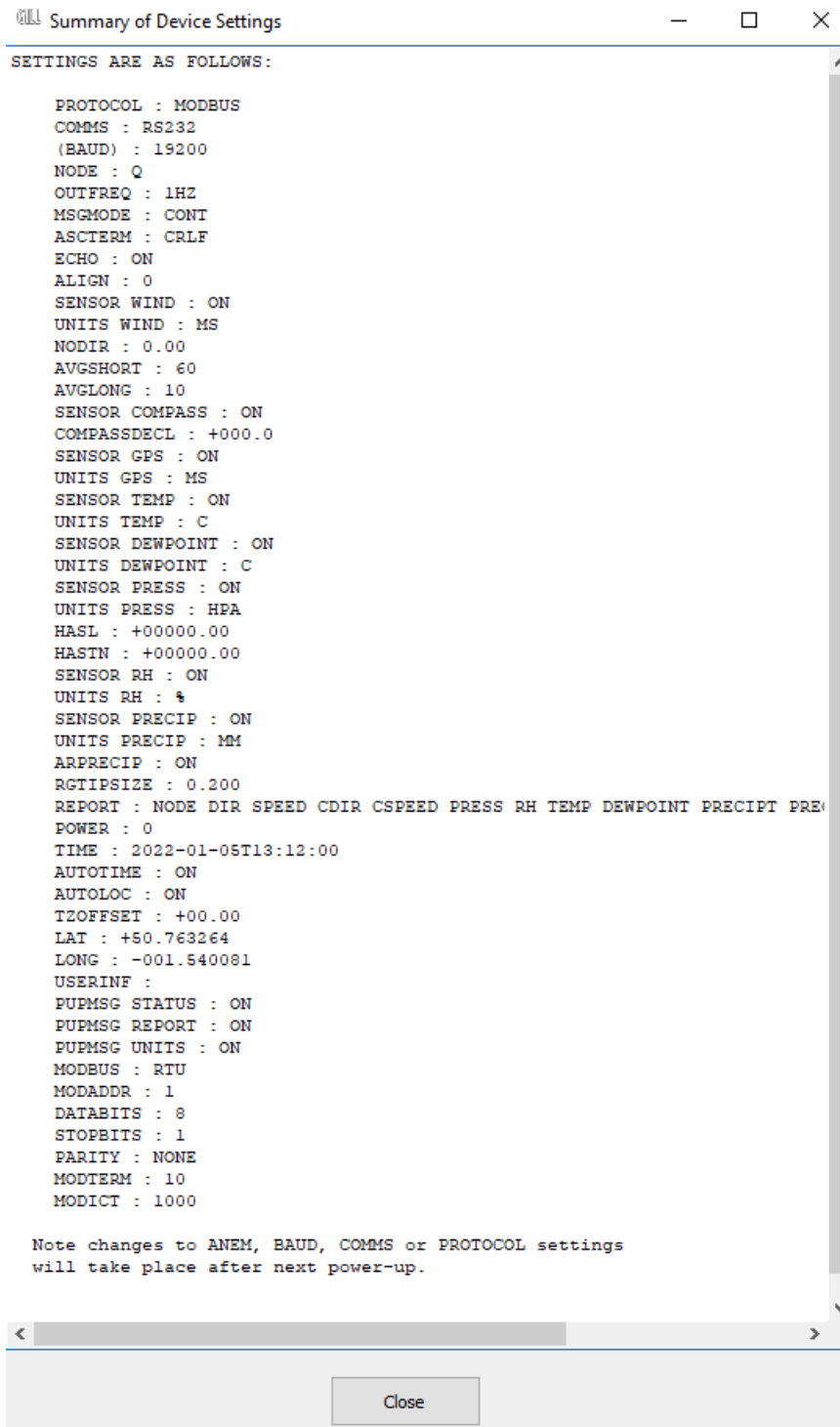

```
Summary of Device Settings
SETTINGS ARE AS FOLLOWS:

PROTOCOL : MODBUS
COMMS : RS232
(BAUD) : 19200
NODE : Q
OUTFREQ : 1HZ
MSGMODE : CONT
ASCTERM : CRLF
ECHO : ON
ALIGN : 0
SENSOR WIND : ON
UNITS WIND : MS
NODIR : 0.00
AVGSHORT : 60
AVGLONG : 10
SENSOR COMPASS : ON
COMPASSDECL : +000.0
SENSOR GPS : ON
UNITS GPS : MS
SENSOR TEMP : ON
UNITS TEMP : C
SENSOR DEWPOINT : ON
UNITS DEWPOINT : C
SENSOR PRESS : ON
UNITS PRESS : HPA
HASL : +00000.00
HASTN : +00000.00
SENSOR RH : ON
UNITS RH : %
SENSOR PRECIP : ON
UNITS PRECIP : MM
ARPRECIP : ON
RGTIPTSIZE : 0.200
REPORT : NODE DIR SPEED CDIR CSPEED PRESS RH TEMP DEWPOINT PRECIPT PRE
POWER : 0
TIME : 2022-01-05T13:12:00
AUTOTIME : ON
AUTOLOC : ON
TZOFFSET : +00.00
LAT : +50.763264
LONG : -001.540081
USERINF :
PUPMSG STATUS : ON
PUPMSG REPORT : ON
PUPMSG UNITS : ON
MODBUS : RTU
MODADDR : 1
DATABITS : 8
STOPBITS : 1
PARITY : NONE
MODTERM : 10
MODICT : 1000

Note changes to ANEM, BAUD, COMMS or PROTOCOL settings
will take place after next power-up.
```

Close

11. MetSet now opens a Safe Mode 4800 baud connection from which all settings can now be read and changed.

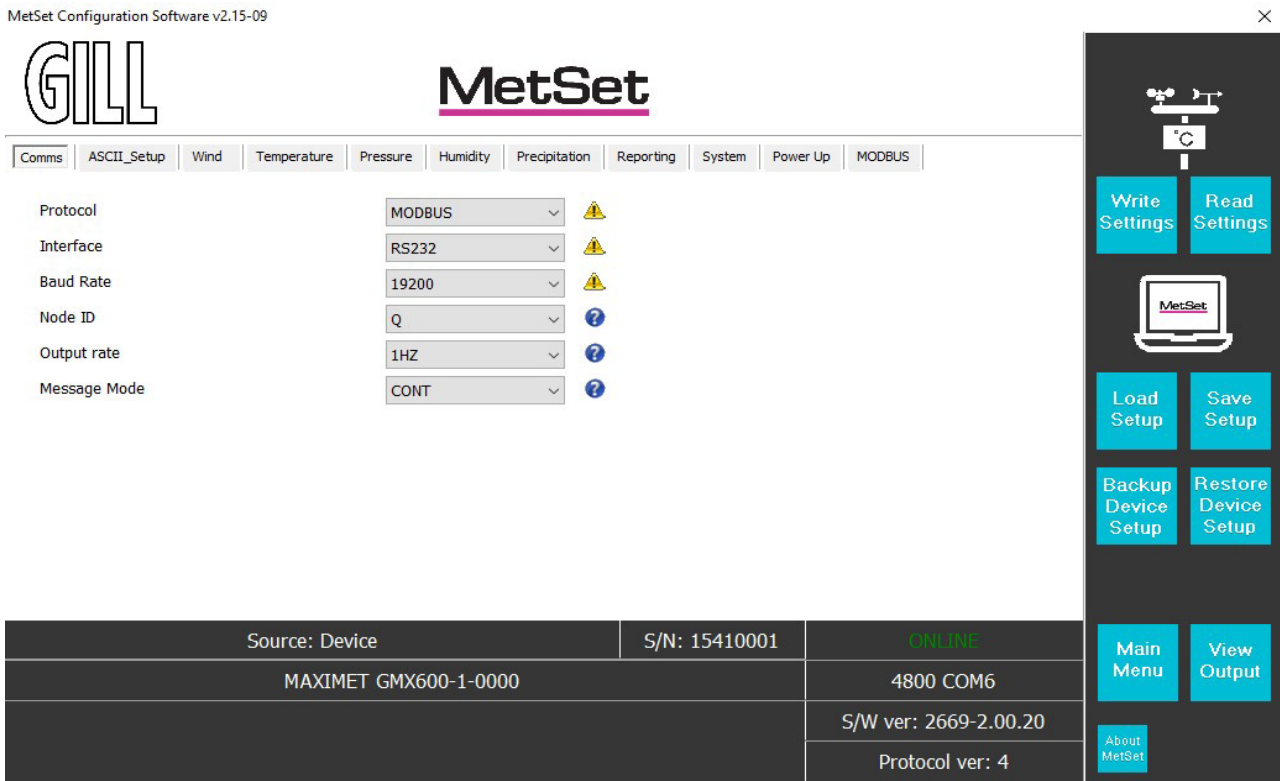

### Safe Mode Method 2 Connection

1. Connect the MaxiMet for RS232 communication as detailed in para 5.5.  
**Note: At this stage the MaxiMet supply should be switched off.**  
**If using the Gill Instruments RS232 to USB configuration cable, then unplug the 9-way connector from the base of the MaxiMet.**
2. **Open a terminal program e.g. Gill Wind Software (obtainable from <http://www.gillinstruments.com/main/software.html>) or equivalent terminal program e.g. Tera-Term, Putty etc.**  
**Note:** If using Gill Wind Software the Tools features are not applicable.
3. Set the Serial Port to the required COM Port connection using the drop down menu and click on the OK button.
4. Set the Baud Rate to 4800 using the drop down menu. A blank Wind terminal screen will be opened.
5. Left click the mouse in the blank terminal screen.
6. Hold down the \* (asterisk) key on the keypad.
7. **With the \* key still held down, apply power to the MaxiMet**  
**If using the Gill Instruments RS232 to USB configuration cable then plug in the 9-way connector to the base of the MaxiMet.**

This will result in placing the unit into SAFE MODE.

8. Press Enter to start a new line (Ignore illegal command line).

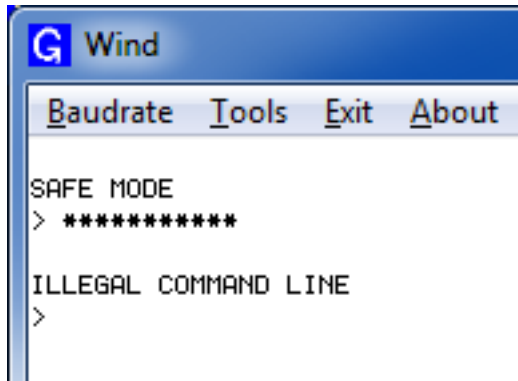

```
G Wind
Baudrate Tools Exit About
SAFE MODE
> *****
ILLEGAL COMMAND LINE
>
```

To now change communication from, say, SDI-12 (or Modbus) or RS422 or RS485 to default RS232:

1. Type COMMS RS232 and press Enter.
2. Type Q and press Enter to exit SAFE MODE.
3. Data will now scroll on screen.

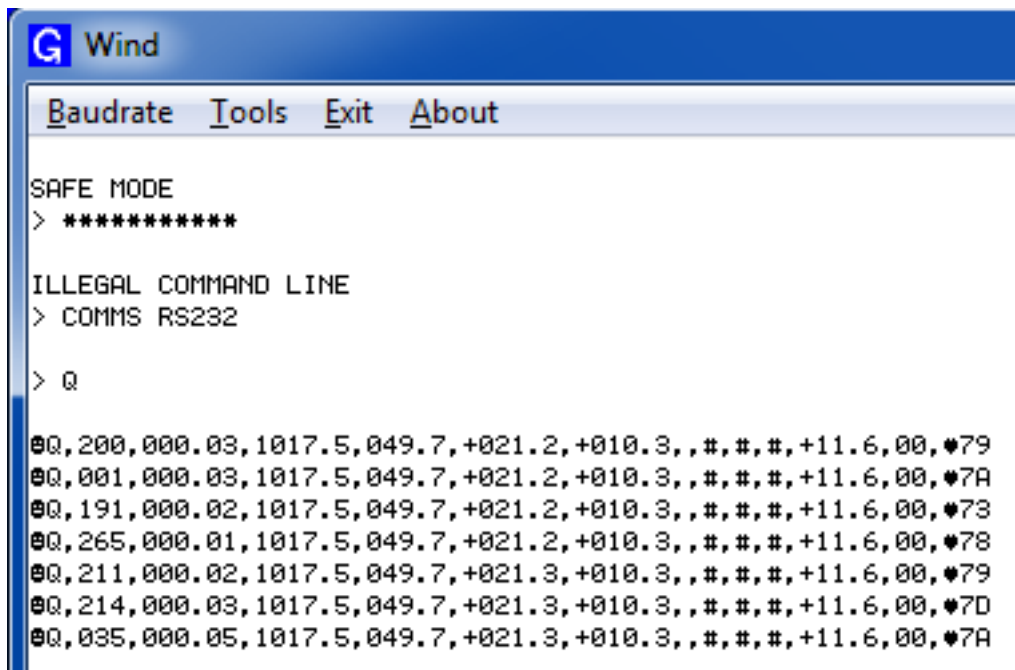

```
G Wind
Baudrate Tools Exit About
SAFE MODE
> *****
ILLEGAL COMMAND LINE
> COMMS RS232
> Q
00,200,000.03,1017.5,049.7,+021.2,+010.3,,#,#,#,+11.6,00,79
00,001,000.03,1017.5,049.7,+021.2,+010.3,,#,#,#,+11.6,00,7A
00,191,000.02,1017.5,049.7,+021.2,+010.3,,#,#,#,+11.6,00,73
00,265,000.01,1017.5,049.7,+021.2,+010.3,,#,#,#,+11.6,00,78
00,211,000.02,1017.5,049.7,+021.3,+010.3,,#,#,#,+11.6,00,79
00,214,000.03,1017.5,049.7,+021.3,+010.3,,#,#,#,+11.6,00,7D
00,035,000.05,1017.5,049.7,+021.3,+010.3,,#,#,#,+11.6,00,7A
```

4. Close the 4800 baud rate Wind or terminal program.
5. **Power down the MaxiMet and re-apply power.** Open Gill MetSet software and read settings/change settings as required.

### Appendix I. Using a Terminal Program to run MaxiMet Tilt function

For those MaxiMet units that have a Tilt function output it is possible to use a Check Tilt command that results in just X, Y, Z Tilt information (and compass output with wind output models) being output at 4Hz with additional decimal point accuracy, should this be required for installation set-up.

1. To enable this Tilt function it is necessary for the MaxiMet to be set and wired for RS232 or RS422 data two-way TX/RX communication and a suitable converter should be used to interface the MaxiMet to a PC running a terminal program.
2. Then connect the MaxiMet data output to a PC and open a terminal program e.g. Gill Wind software (note the Wind software Tools features are not applicable).
3. Select the required COM port connection e.g. COM 39.

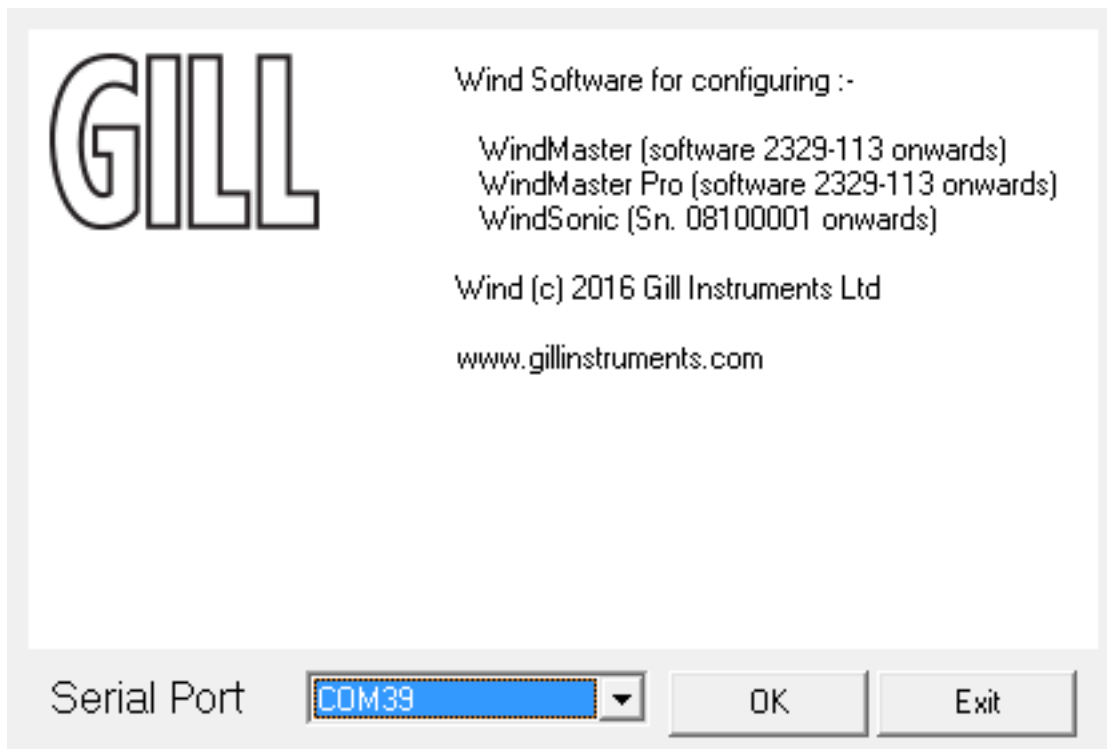

4. Select the baud rate from the drop down menu to match the MaxiMet setting (default 19200 baud)
5. MaxiMet data should scroll on screen.
6. Type \* (asterisk) to set the MaxiMet to SETUP MODE.
7. Type CHECKTILT and press the Enter key for 4Hz data output.
8. Adjust the MaxiMet positioning to achieve required tilt angles e.g. 0.0, 0.0,1 for ideal horizontal set up.
9. To return to MaxiMet's pre-configured normal measurement output, power down and then power up the unit.



The Check Tilt function is not a memorised setting and as soon as power is reset the unit reverts to its pre-configured data string output setting.

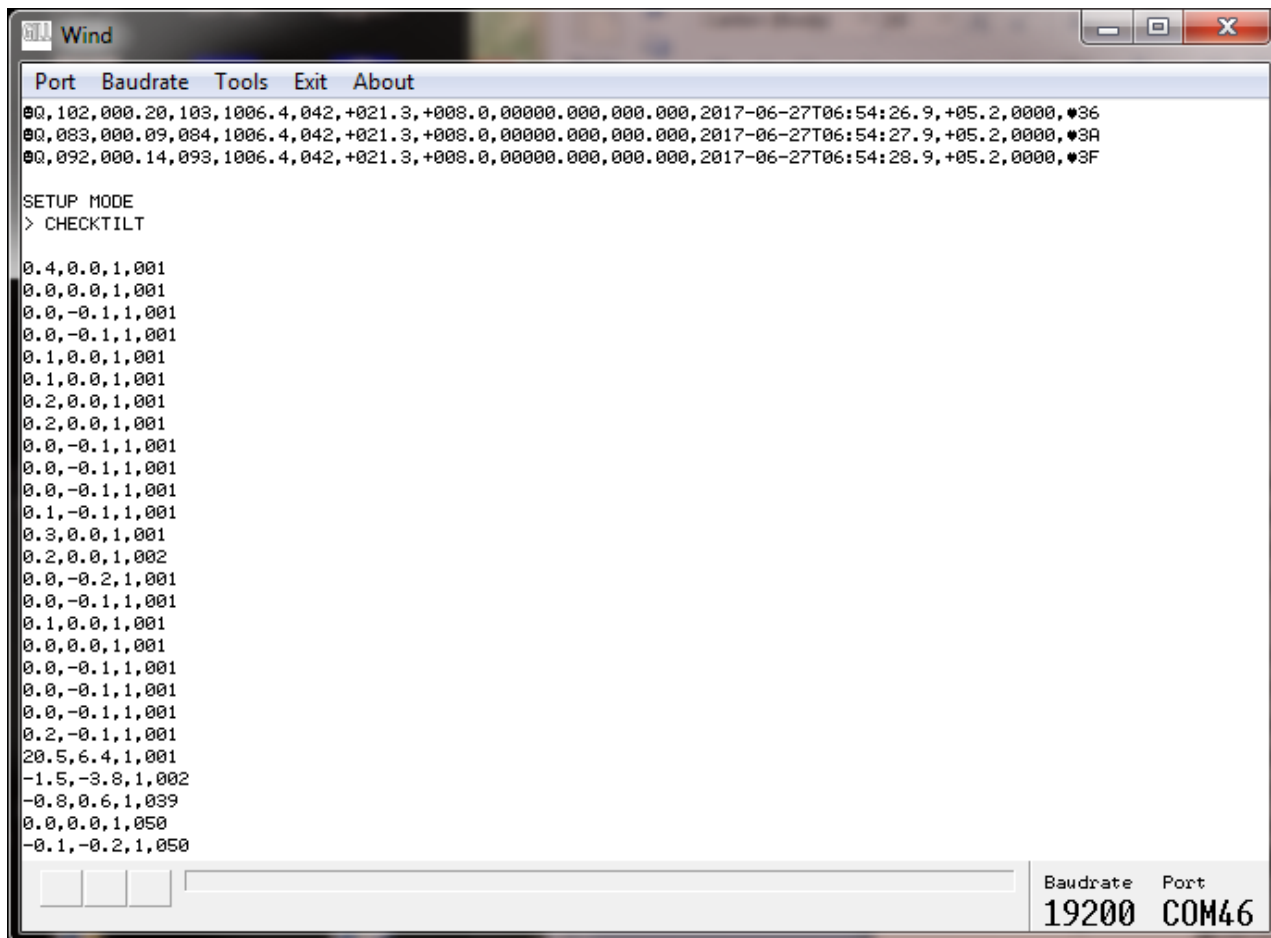

### Appendix J. Using a Terminal Program to set MaxiMet Date and Time

As an alternative to using MetSet to set MaxiMet time which might add a delay to time setting as MetSet saves settings (up to 60 seconds) then MaxiMet TIME can be set manually with potentially more accuracy against a reference time as follows.

1. With the MaxiMet set and wired for RS232 or RS422 data two-way TX/RX communication via a suitable converter, interface the MaxiMet to a PC running a terminal program.
2. Open a terminal program e.g. Gill Wind software (note the Wind software Tools features are not applicable) or Tera Term or Putty etc.
3. Select the required COM port connection e.g. COM 39.

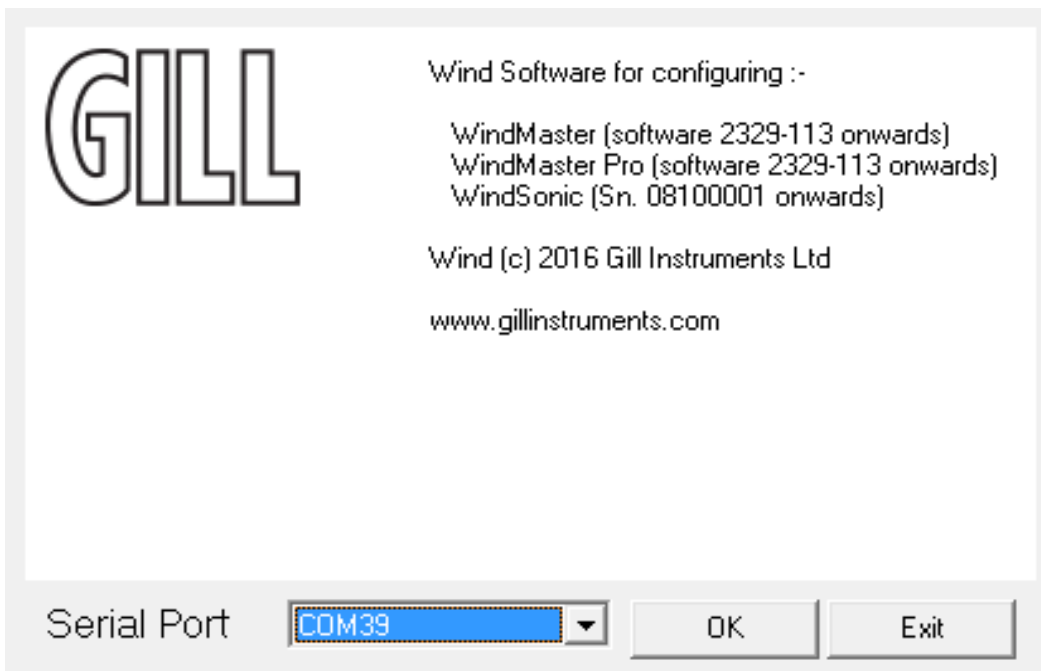

4. Select the baud rate to match the MaxiMet setting (default 19200 baud).
5. MaxiMet data should scroll on screen.  
Q,027,000.23,311,1018.8,041,+025.4,+011.5,0002,2017-06-01T15:21:30.0,+05.2,0000,18  
Q,045,000.14,330,1018.8,041,+025.4,+011.5,0002,2017-06-01T15:21:31.0,+05.2,0000,1A
6. Type \* (asterisk) to set the MaxiMet to SETUP MODE.
7. Type TIME and Press the PC Enter key to show the current date and time (and format).  
TIME = 2017-06-01T15:25:00
8. To set a new TIME choose a convenient Time in the future say 5 minutes ahead.
9. Now Type in the new Date/Time in the following format: -  
TIME 2017-06-01T15:30:00  
(Year/Month/Day/Hours/Minutes/Seconds)
10. Using a reference accurate clock/watch showing current time compare this to the time set above.
11. When the two TIMES are matched press, the PC Enter key to update the MaxiMet TIME to the reference t
12. Type Q and press the Enter key to return the MaxiMet to Measurement mode with the updated TIME reading.

### Appendix K. Using a Terminal Program to Apply Temperature and Relative Humidity Correction (GMX552 only)

It may be necessary to periodically calibrate the temperature and relative humidity sensors in the MaxiMet GMX552 and Wet Bulb Temperature Sensor in accordance with local or regional legislation. The GMX552 allows the user to input calibration values (up to 4-points) such that a measurement correction is applied.

#### Please contact Gill Instruments for calibration options.

The parameters available for calibration are as follows:

DRY	Ambient 'dry' temperature
WWB	'Wet' wet bulb temperature (from external Wet Bulb Sensor)
BG	Black globe temperature
RH	Relative humidity

Corrections based on inputted calibration values will be determined using the following rules:

- Corrections will be calculated from the difference between reported and actual values.
- If one calibration point is supplied, this will be an offset for all reported values.
- If two or more calibration points are supplied, the offset will be an interpolation between the points.
- For values below the minimum calibration point, the offset at the minimum calibration point is applied.
- For values above the maximum calibration point, the offset at the maximum calibration point is applied.

#### How to Read Calibration Table and Input Calibration Values

##### Entering Setup Mode

1. With the MaxiMet set and wired for RS232 or RS422 data two-way TX/RX communication via a suitable converter, interface the MaxiMet to a PC running a terminal program.
2. Open a terminal program e.g. Gill Wind software (note the Wind software Tools features are not applicable) or Tera Term or Putty etc.

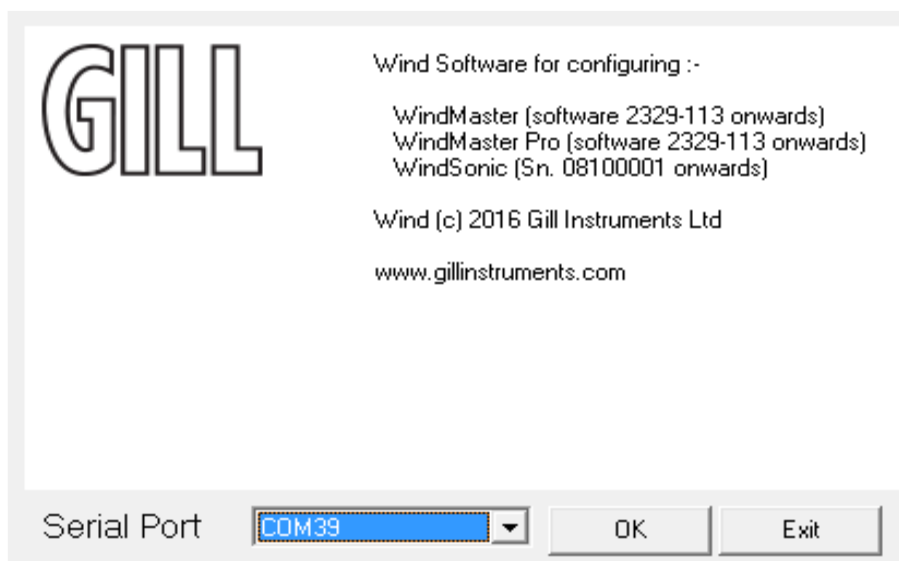

## Compact Weather Station

3. Select the required COM port connection e.g. COM 39.
4. Select the baud rate to match the MaxiMet setting (default 19200 baud).
5. MaxiMet data should scroll on screen.  
Q,027,000.23,311,1018.8,041,+025.4,+011.5,0002,2017-06-01T15:21:30.0,+05.2,0000,18  
Q,045,000.14,330,1018.8,041,+025.4,+011.5,0002,2017-06-01T15:21:31.0,+05.2,0000,1A
6. Type \* (asterisk) to set the MaxiMet to SETUP MODE.

### Reading Calibration Table

#### To view the entire calibration table for a given parameter.

1. Put the MaxiMet into SETUP MODE (see above).
2. Type USERCAL and the parameter required to view (DRY, WWB, BG, RH).

Example:  
USERCAL DRY returns the entire dry temperature calibration table

3. Type Q and press the Enter key to return the MaxiMet to Measurement mode

#### To view the first line in a given calibration table

1. Put the MaxiMet into SETUP MODE (see above).
2. Type USERCAL, the parameter required to view (DRY, WWB, BG, RH) and the index of the line required (0,1,2,3).

Examples:  
USERCAL DRY 0 returns the first entry in the dry temperature calibration table  
USERCAL BG 1 returns the second entry in the black globe temperature calibration table

3. Type Q and press the Enter key to return the MaxiMet to Measurement mode

#### To view a specific value in a given calibration table

1. Put the MaxiMet into SETUP MODE (see above).
2. Type USERCAL, the parameter required to view (DRY, WWB, BG, RH), the index of the line required (0,1,2,3) and the type of value of interest (REP, ACT).

Examples:  
USERCAL DRY 0 REP returns the reported value for the first entry in the dry temperature calibration table.  
USERCAL RH 1 ACT returns the actual value for the second entry in the relative humidity calibration table.

3. Type Q and press the Enter key to return the MaxiMet to Measurement mode

## Compact Weather Station

### Clearing / Resetting Calibration Table

#### To clear an entire calibration table for a given parameter

1. Put the MaxiMet into SETUP MODE (see above).
2. Type USERCAL, the parameter to be cleared (DRY, WWB, BG, RH) and -1.

Example:

USERCAL DRY -1                      clears the dry temperature calibration table

3. Type Q and press the Enter key to return the MaxiMet to Measurement mode with the calibration table cleared.

### Setting a Calibration Point

1. Put the MaxiMet into SETUP MODE (see above).
2. Type USERCAL, the parameter required to set (DRY, WWB, BG, RH), the index of the line to be set (0,1,2,3), the reported temperature and the actual temperature.

Examples:

USERCAL WWB 0 20.1 21.1      sets the first line of calibration for the wet bulb, reported temperature is 20.1, actual temperature is 21.1

USERCAL BG 3 49.5 50.2      sets the last line of calibration for the black globe, reported temperature is 49.5, actual temperature is 50.2

3. Type Q and press the Enter key to return the MaxiMet to Measurement mode with the new calibration point set.



To maintain the highest accuracy, the reported and actual values should be taken from an accredited calibration certificate/test facility.



Calibration values must be inputted in the same units as the configured output of the MaxiMet (°C, K, °F). Any read-outs of the calibration tables will be similarly configured.



Calibration table entries must be ordered low to high.



Calibration temperatures have a maximum possible value of 163.83°C.

### Appendix L. Using Gill MetView Software to View the MaxiMet Data String

Install MetView software (V2.14 onwards) on to a PC from the Gill website at:

<http://gillinstruments.com/main/software.html>

MetView software allows you to view the MaxiMet data visually and has a simple data logging facility. Before you can use MetView, check that MaxiMet is correctly connected to a serial COM port or USB COM port on your PC.



MetView is compatible with RS232 and RS422 connected units set for ASCII only. MetView will not read NMEA, SDI-12 or Modbus data strings.

#### Opening MetView

Click on the MetView button on your PC's desktop or choose **Start > Programs > MetView > MetView**. The MetView Control Centre window is displayed as follows:



## Compact Weather Station

### Connection is 'Receive-Only'

Use (tick) if the MaxiMet connection to the PC has only transmit wires connected and a MetSet version of its current device settings is available to upload to MetView. Select 'Connection is 'Receive-Only'' tick box and click on the Scan button. Upload a MetSet generated device file from a PC location as directed.

### Connect to first device found

Selecting this box (default setting) means that if multiple MaxiMets are connected to the PC, MetView will connect to the MaxiMet connected to the lowest-number COM port.

If the 'Connect to first device found' option is not selected, then all connected MaxiMet COM port connections will be shown when the Scan button is selected.

### Scan Button

If MaxiMet transmit and receive wires are connected to the PC, then use the Scan button to connect to MetView.

### Scanning for Devices

To set up communications between MetView and a connected MaxiMet:

1. Click on the Scan button to search the available COM ports for connected MaxiMet units.

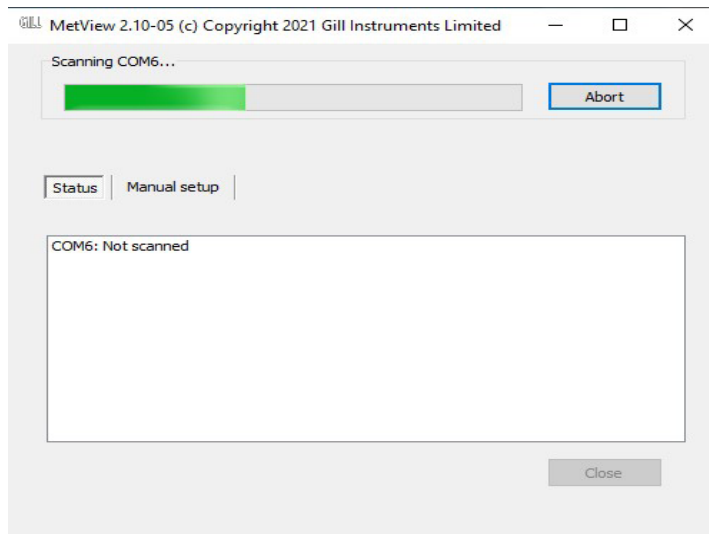

- a. If **connect to first device found** has been selected, then MetView will automatically connect to the MaxiMet on COM Port 6 (connects to lowest numbers first) and open the MaxiMet data view screen showing all of the MaxiMet parameters that have been enabled as outputs.
  - b. If **connect to first device found** is deselected, then click on the Scan button. MetView will then allow the required MaxiMet connection to be made using the blue background highlighted drop down menu.
2. Select Connect to go to the data view screen.
  3. To select the other MaxiMet then in the data view screen select the Disconnect button and use the drop-down menu below to select and connect to the new MaxiMet.

MetView 2.11-01 (c) Copyright 2023 Gill Instruments Limited

×



English ▾

**Viewing Software**

MaxiMet® MetConnect MetPak

Select a configuration file

Select the sensor that you would like to connect to

COM4: UNKNOWN\_DEVICE @baud: 9600 ▾

Connect

Troubleshoot

Rescan

Select a configuration file

### The MetView Console

When connected correctly, MetView displays its data-monitoring console. This consists of gauges for all of MaxiMet enabled parameters.

Buttons beneath each of the gauges allow you to choose the displayed units and other options. Each gauge also shows the maximum and minimum values recorded during the current session. The wind speed gauge also shows the maximum gust speed.



MetView will not show data if the unit is set for Modbus or SDI-12 format. An example MetView screen (part of) is shown below (default output).

MetView 2.10-05 (c) Copyright 2021 Gill Instruments Limited

GILL MetView

<p><b>Wind Direction</b> 173° Min: 77° Max: 228°</p> <p>Markers: Maritime, RSEW</p>	<p><b>Wind Speed</b> 0.04m/s Min: 0.01m/s Max: 0.06m/s Gust: 0.06m/s</p> <p>Markers: Max/Min, Max Gust m/s, mph, mph, kts, fpm</p>	<p><b>Corrected Wind Direction</b> 62° Min: 328° Max: 117°</p> <p>Markers: Maritime, RSEW</p>	<p><b>Corrected Wind Speed</b> 0.04m/s Min: 0.01m/s Max: 0.07m/s Gust: 0.07m/s</p> <p>Markers: Max/Min, Max Gust m/s, mph, mph, kts, fpm</p>	<p><b>Pressure</b> 1017.2mbar Min: 1017.1mbar Max: 1017.2mbar</p> <p>Markers: hPa, mbar mmHg, mmHg</p>	<p><b>Humidity</b> 43.0% Min: 43.0% Max: 43.0%</p>	<p><b>Temperature</b> 21.5°C Min: 21.5°C Max: 21.6°C</p> <p><b>Dew Point</b> 8.5°C °C, °F, °K</p>
---	--	---	--	--	--	---

Averaging: Real Time, 2 min, 30 min  
Max/Min Markers: on, off, reset

Connection Status: Connected ✓ 1.00Hz  
2669 "MAXIMET GMX600-1-0000" 2.00.20 [Q] PV=4  
Wed 05 Jan 2022 14:22:01



### Connection status indicators

Reading	Function
Green Background Tick	Indicates that the MaxiMet is logging or communicating with MetView correctly, as well as reading the MaxiMet firmware version.
Red Background Cross	Indicates that the MaxiMet is not logging or connected/communicating with MetView.
1.00Hz	Indicates the output rate of the MaxiMet when connected. Reads when the unit is communicating correctly with MetView.
Wed 05 Aug 2015 12:34:45	Real time PC date and time indication.

Remaining MetView default output screen shown below.

×

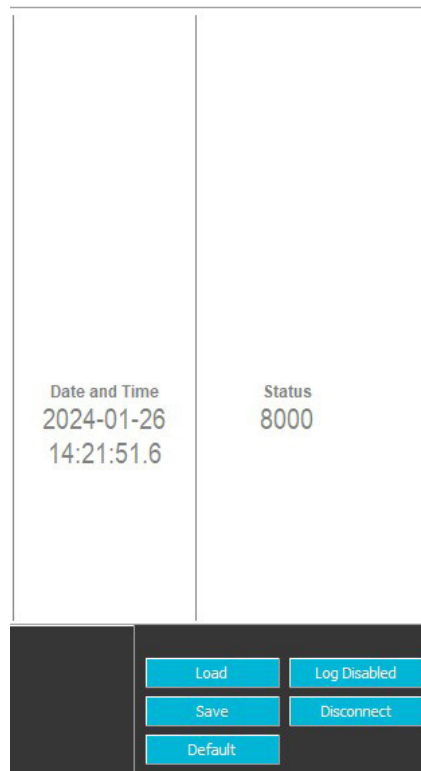

No gauges are associated with the above digital readouts.

The order in which the instruments are shown in the MetView display reflects the order in which the instrument data appears in the MaxiMet data string.

## Compact Weather Station

### MetView Console Display Options

Units shown in bold on the MetView screen denote default settings.

### MetView Scale and Units of Measure Options

MetView Console buttons can convert data from the MaxiMet to read different units of measure or scale settings, or in the case of Wind readings the type of display (e.g. Maritime, NSEW).

On-screen MetView settings do not alter the actual MaxiMet configuration settings or MaxiMet logged data parameters and units of measure.

### MetView Averaging Options

Setting	Function
Real Time	Choose this button for no averaging
2 Min	Select for on screen 2 minute rolling average for all sensor readings
10 Min	Select for on screen 10 minute rolling average of all sensor readings

### MetView Max/Min Markers

Setting	Function
Off	Maximum and Minimum Markers on all applicable gauges turned off
On	Maximum and Minimum Markers on all applicable gauges turned on
Reset	Reset all applicable gauge Maximum/Minimum Markers and all digital Maximum/Minimum reading at will

### MetView Screen Settings Options

Setting	Function
Save Settings	Will save all the current MetView screen settings to a file location as a .msf file for later retrieval if required.
Load Settings	Will load and update the MetView screen with a previously saved .msf file setting. For use when only a MaxiMet transmit connection is available
Default Settings	Will return all MetView screen settings to factory default.

### MetView Gauge Ranges and Graphs

#### Gauge Range Settings

MetView thermometer style gauge ranges may be altered to view changes in sensor readings more visibly. These changes only affect MetView settings and do not affect the MaxiMet output or logged data. For instance, if the typical Temperature measurement range required is from 0 to +30 °C then the temperature gauge range can be adjusted to reflect this.

1. Place the mouse pointer over the Temperature display gauge and double click to bring up the Set Gauge Range screen. Change Min and Max readings to the required values, e.g. Min: 0, Max: +30.
2. Click on Set. The Temperature gauge range will be updated to reflect the change.

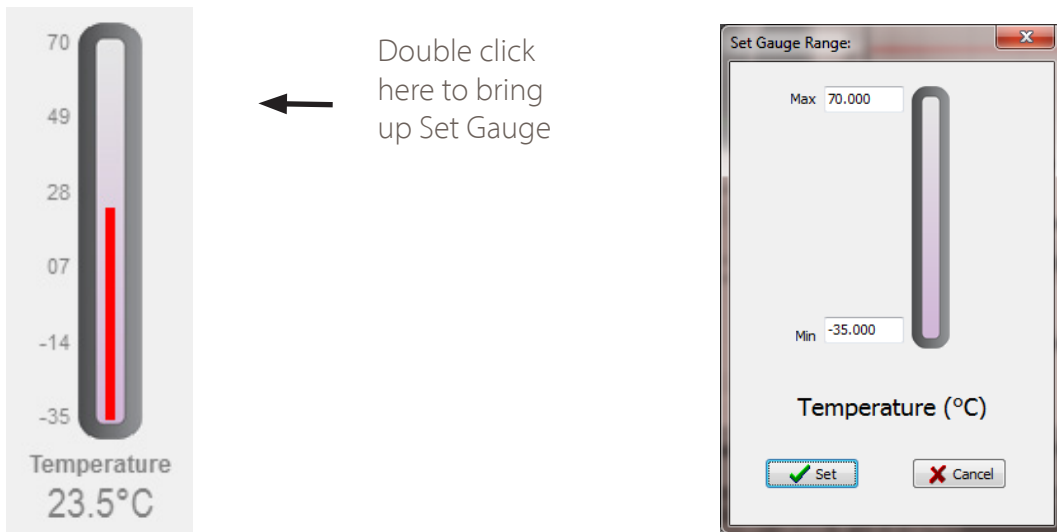

1. Open Set Gauge Range window by double clicking on the display gauge.

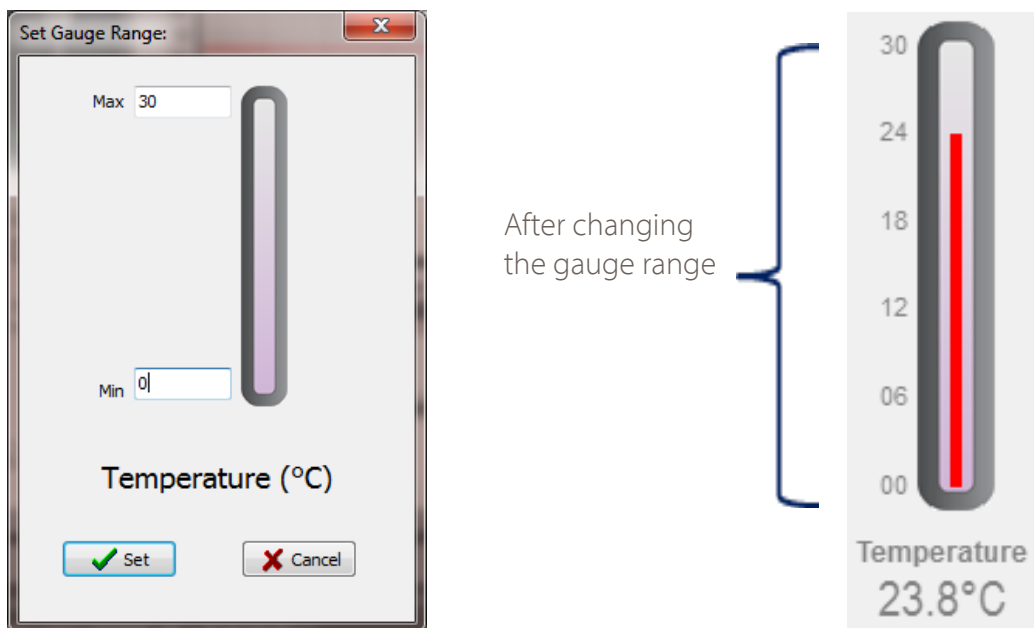

2. Change Max and Min values as required and click Set to update the display gauge

## Compact Weather Station

### Graphs

MetView allows data detected over the last minute, last 1 hour and last 24 hours to be accessed and shown on a graph.



Data is only shown up to the time when the graph function is selected; the graph is not updated once opened. Data is collected from the time that MetView is opened and reading data from a MaxiMet.



Double click on the reading to bring up the time series data

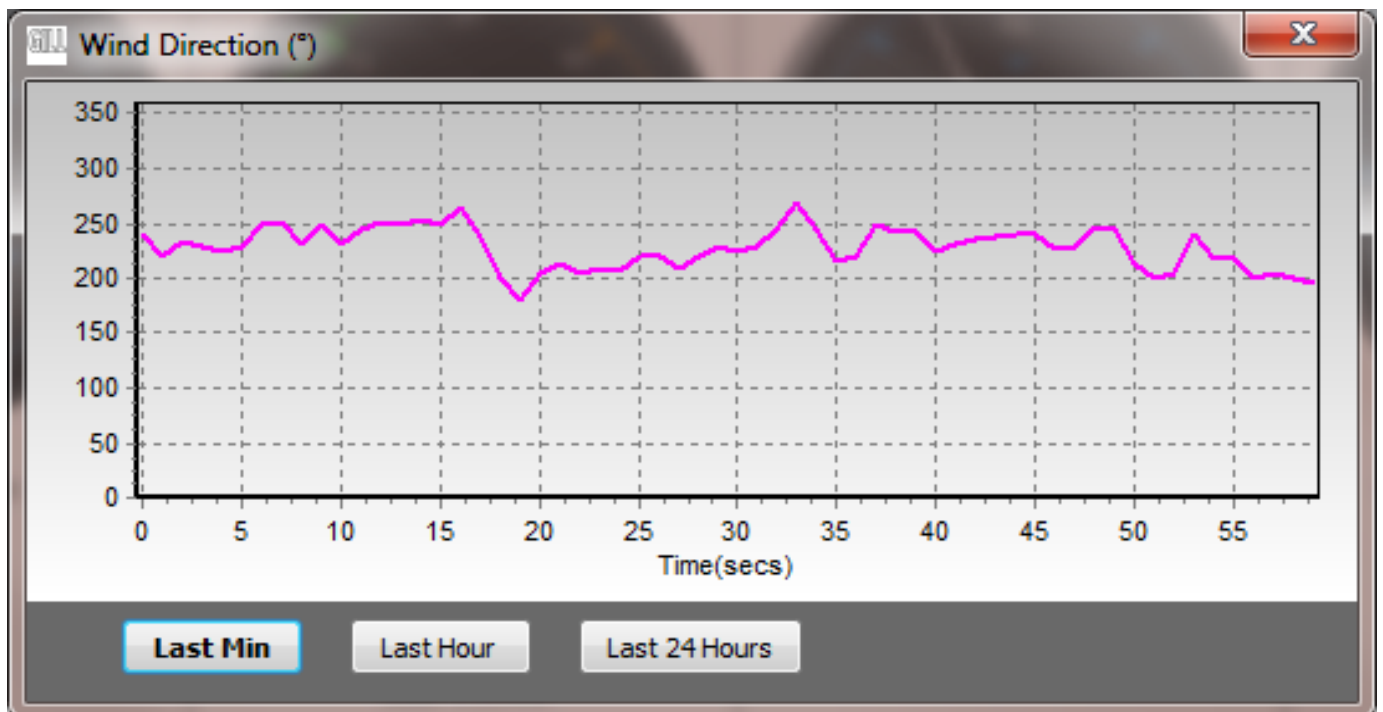

Click on the Last Min, Last Hour or Last 24 Hours buttons as required to view data.

### Data Logging



MetView logs data based on the MaxiMet configuration not on the MetView console settings. To start, click on the **Log disabled** button  on the open MetView console.

The Logging dialog box is displayed.

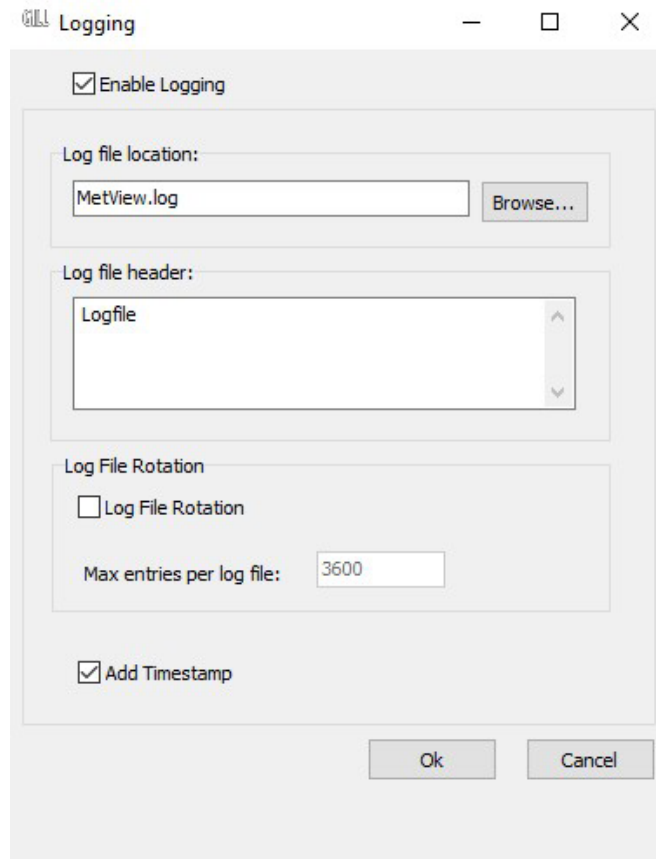

Set up a logging file:

Log file location:

Log file header:

Log file rotation:

Add timestamp:

To start logging:

Select **Enable Logging** (adds a tick to the box).

Click on the **Browse** button to identify the folder where you want to store the data file. Enter the name of the file.

If required, type some notes on the data that is to be recorded which will appear at the top of the saved data log file.

Set up segmented logging with each logged file length determined by the number entered in the text box below. The figure 3600, for example, means that each log file length will be 3600 lines of data. The maximum number of entries per log file is limited to 65535 and a maximum of 2048 log files can be created.

Select to add date and time to the logged data file taken from the PC clock.

Check that the **Enable Logging** option is selected.

Click on the **OK** button to commence logging and return to the console.

## Compact Weather Station



To show that data is being recorded the Logging buttons will change from LOG DISABLED to LOG ENABLED, as displayed below.



To stop logging: Click on the **Log Enabled** button on the MetView console. Clear the **Enable Logging** check box. Click on the **OK** button. If logging has stopped, the Logging button shows a red-background cross instead of the green-background tick (see above).

An example of the logged MaxiMet data .log file opened by Notepad is shown below:

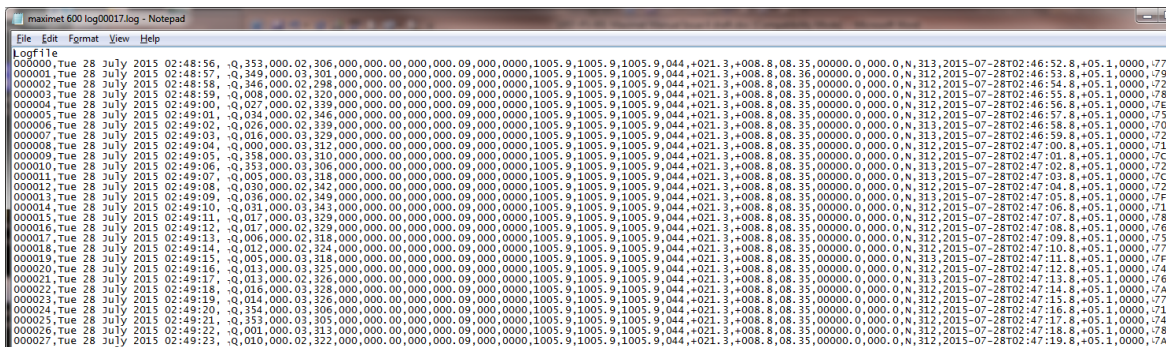

### Use a Terminal Program to View the MaxiMet Data String

There are many terminal programs that might be used to view the MaxiMet data string, e.g. HyperTerminal, Putty, Tera Term etc.

If, for example, Tera Term is used:

1. Open Tera Term.
2. Select Serial.
3. Select MaxiMet connected COM port.
4. Click on OK

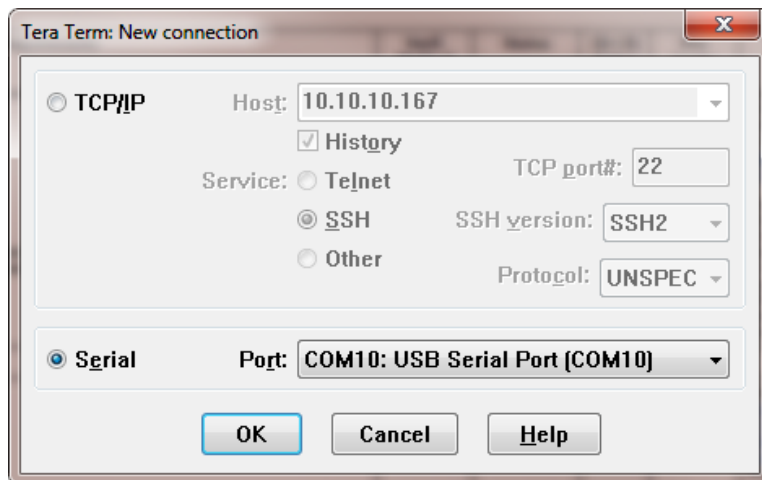

## Compact Weather Station

5. Tera Term opens at 9600 baud by default, but MaxiMet uses 19200 as a default, so change Tera Term baud rate setting to 19200.

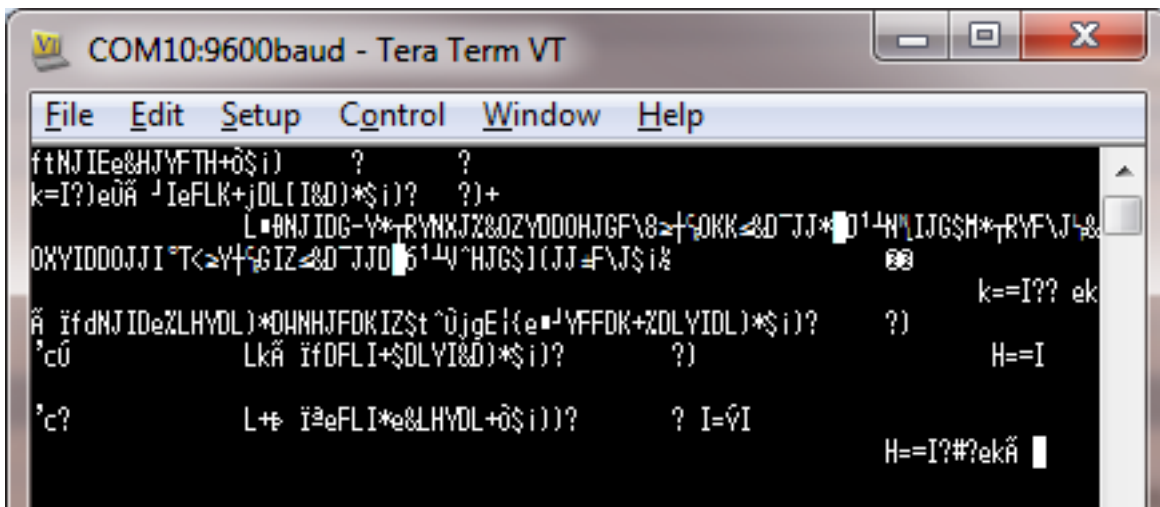

- Select Setup from the top menu.
- Click on Serial Port from the drop down menu.
- Change baud rate to 19200.
- Click on OK.

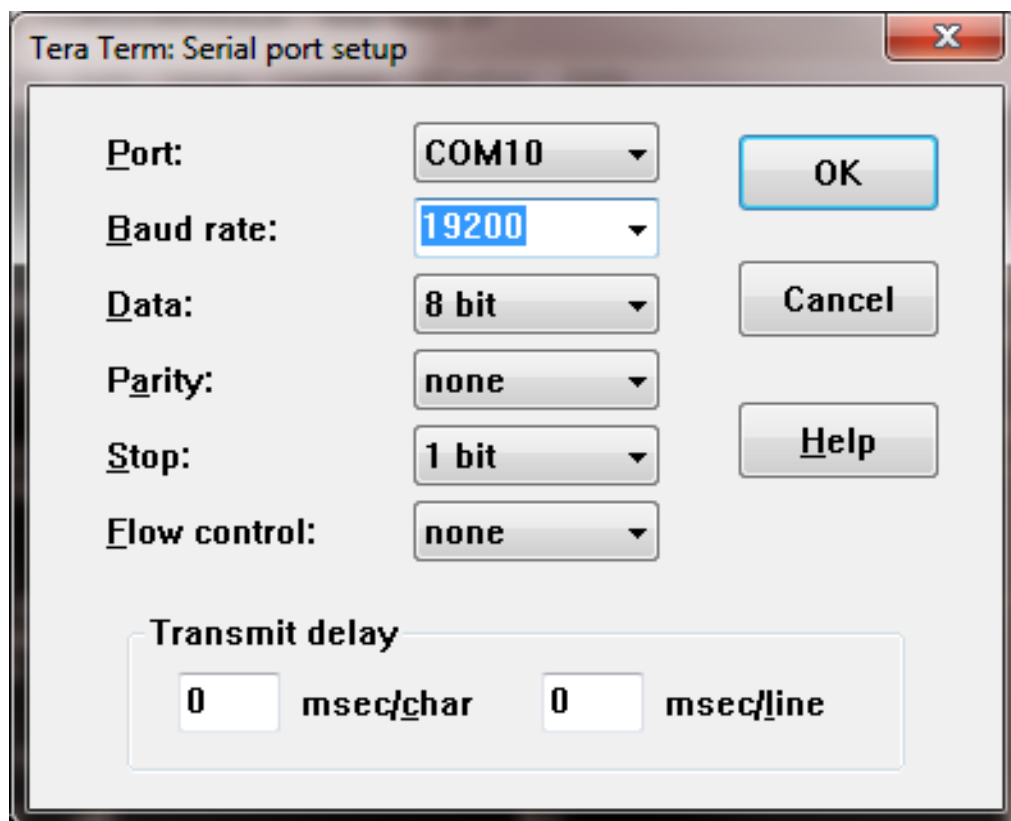

Data will be output as follows:

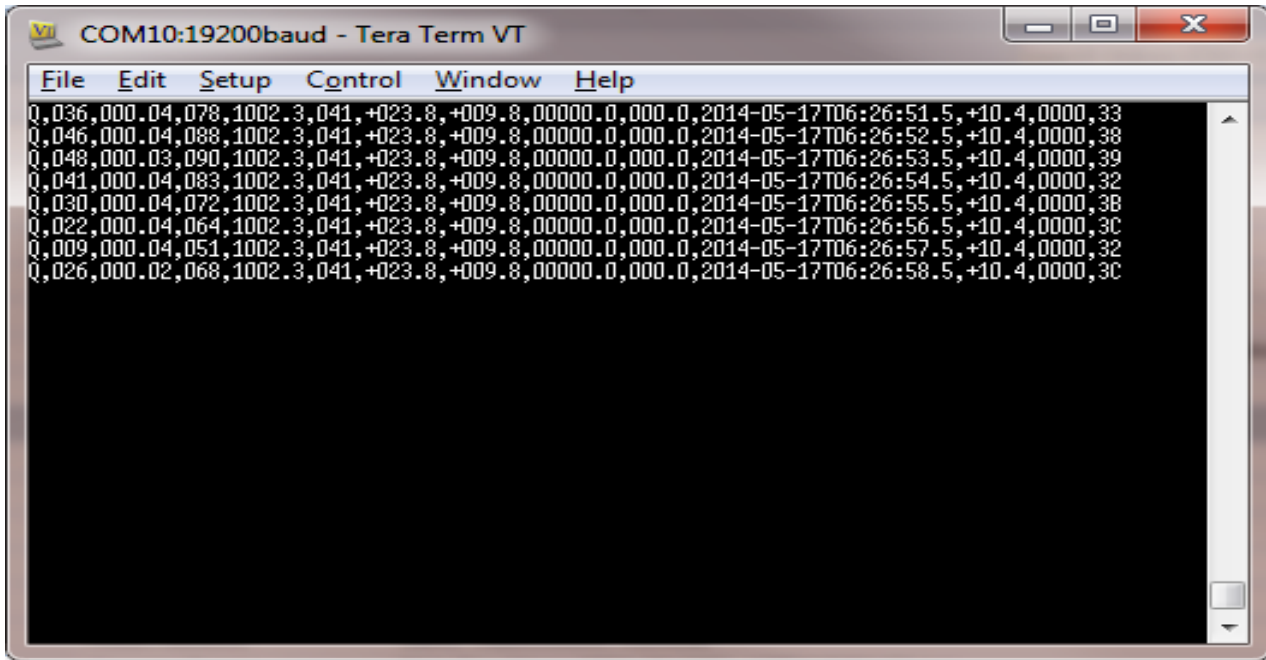

### Use a Terminal Program to View the MaxiMet Data String

There are many terminal programs that might be used to view the MaxiMet data string, e.g. HyperTerminal, Putty, Tera Term etc.

If, for example, Tera Term is used:

6. Open Tera Term.
7. Select Serial.
8. Select MaxiMet connected COM port.
9. Click on OK.

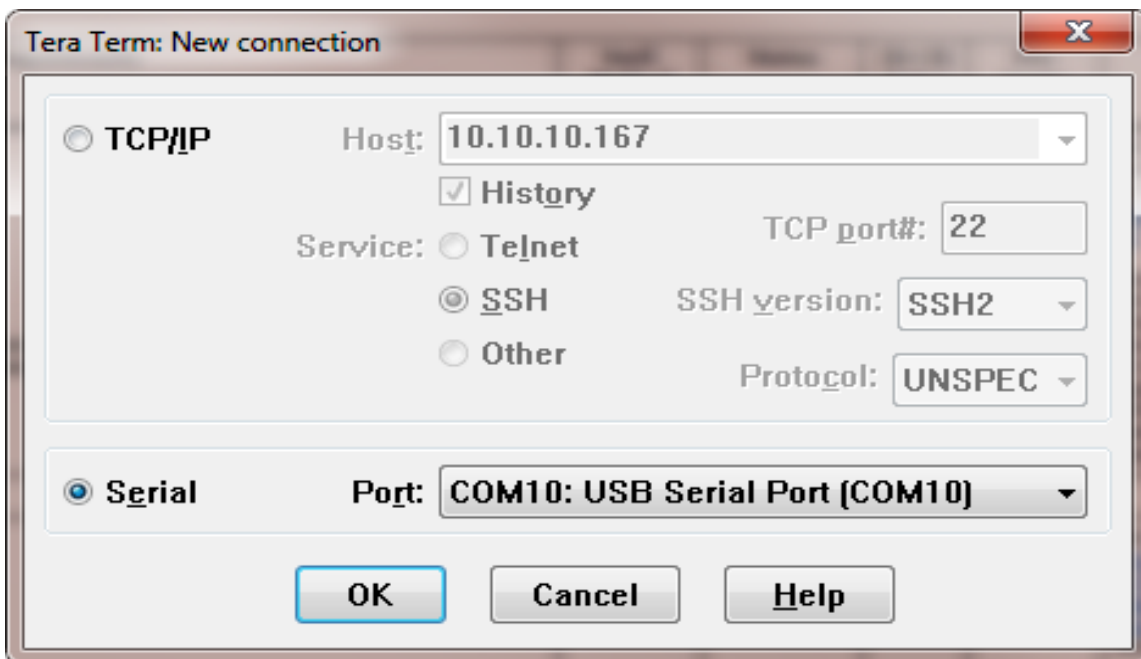

## Compact Weather Station

10. Tera Term opens at 9600 baud by default, but MaxiMet uses 19200 as a default, so change Tera Term baud rate setting to 19200.

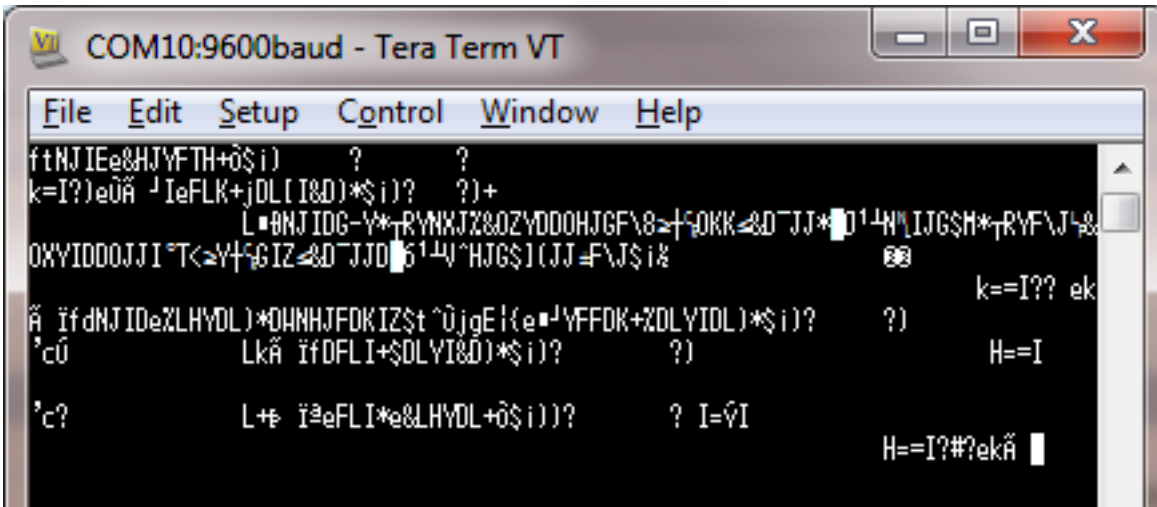

- a. Select Setup from the top menu.
- b. Click on Serial Port from the drop down menu.
- c. Change baud rate to 19200.
- d. Click on OK.

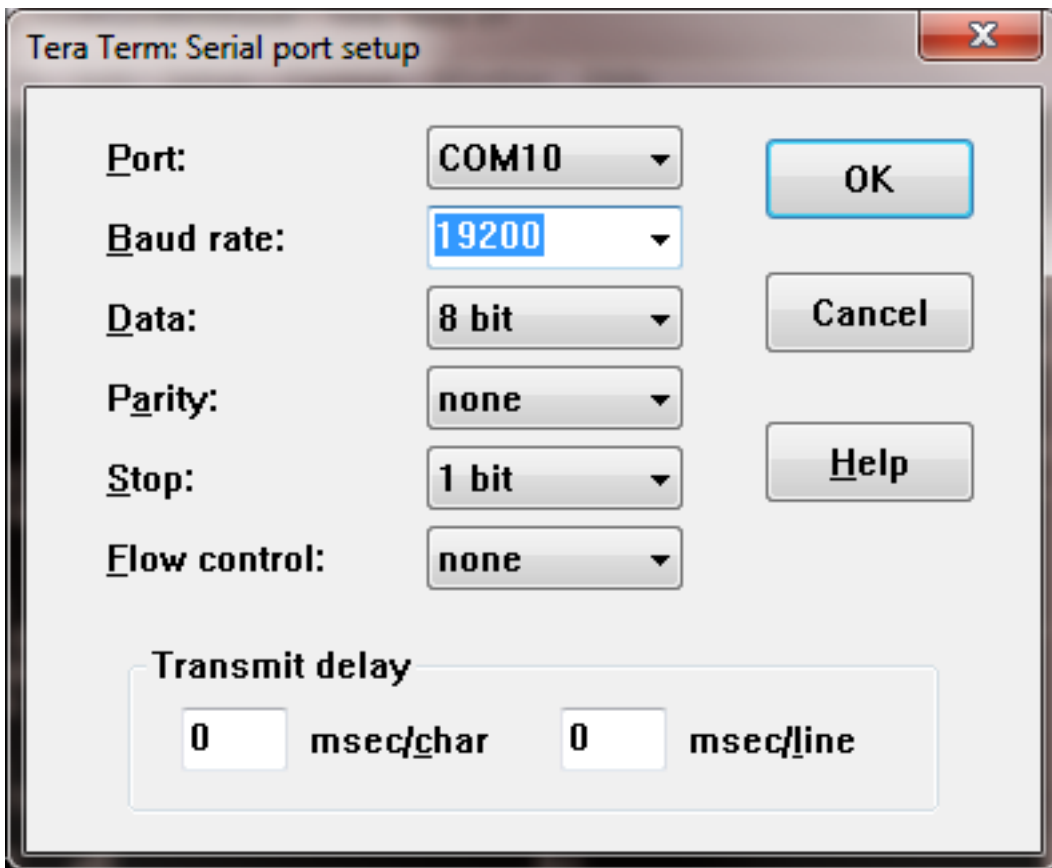

Data will be output as follows:

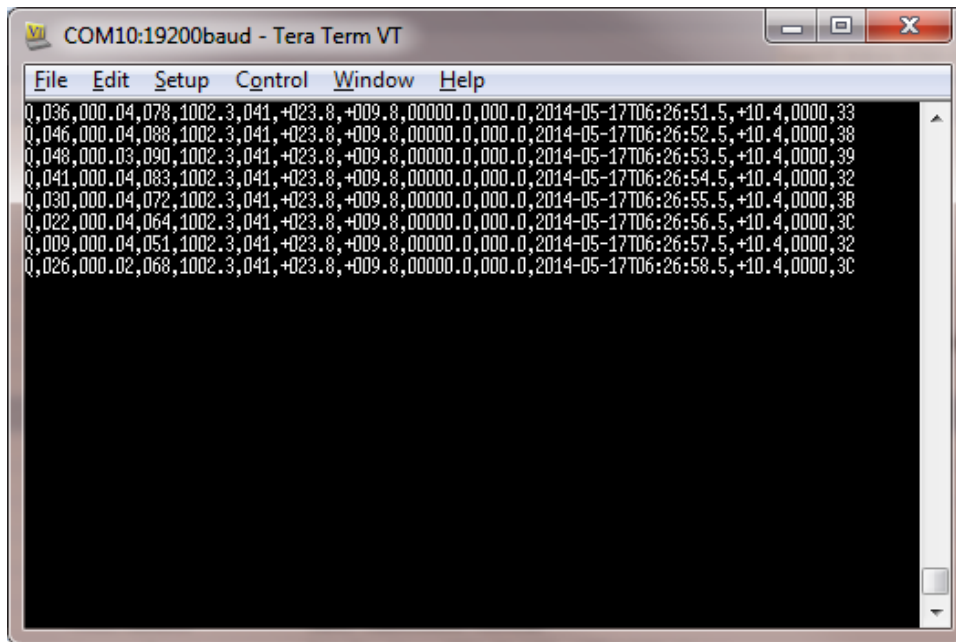

### Creating a logging file

1. Select **File > Log**.
2. Select **Save in** destination, e.g. Desktop.
3. Add the name for the log file in **File Name**, e.g. Tera Term.
4. Tick options as required e.g. Timestamp.
5. Click on **Save**.

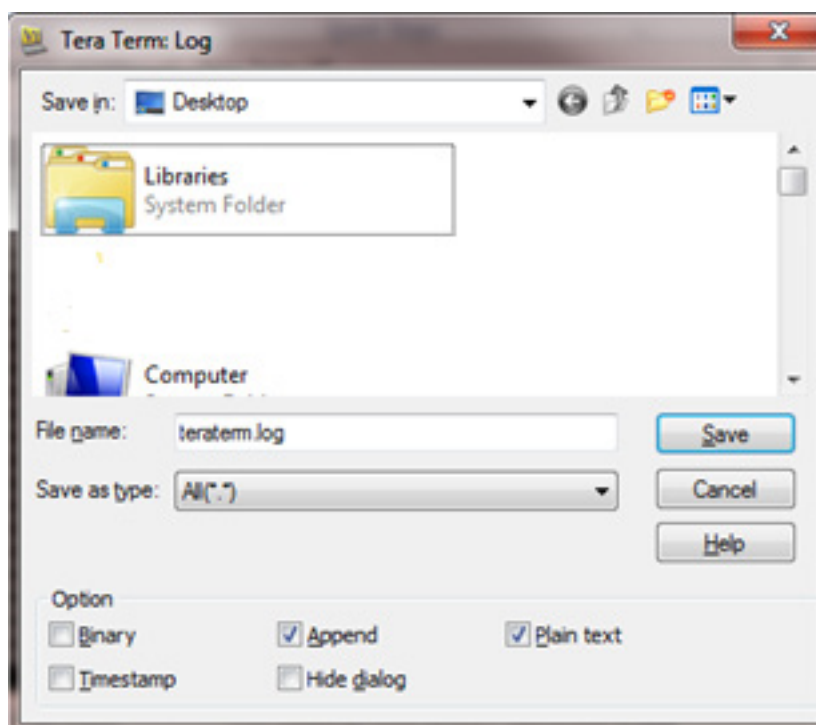

6. The following dialog box will open on the PC desktop.

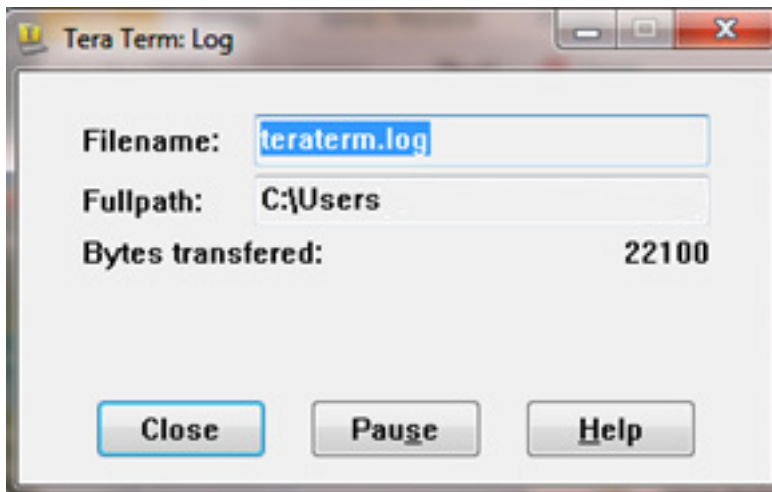

### Understanding Logged Data

Logged data is stored to a file with a .log extension. This can be viewed in any text/HTML editor or spreadsheet a

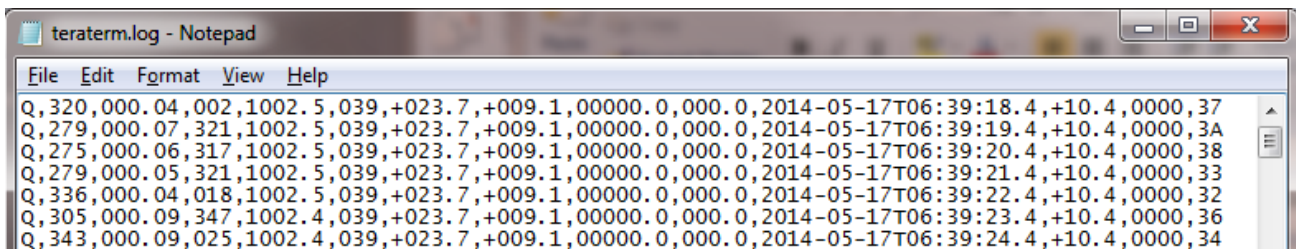

### Appendix M. Maintenance & fault-finding

#### Cleaning and Handling

Ideally when installing the unit handle with lint free gloves and degrease the unit to reduce the build-up of deposits.

#### Servicing

There are no moving parts requiring routine maintenance.

Opening the unit will void the warranty and the calibration.

In the event of failure, prior to returning the unit to your authorised Gill distributor, it is recommended that:

- All cables and connectors are checked for continuity, bad contacts, corrosion etc.
- A bench test is carried out.
- Contact your supplier for advice if failure persists.

#### Precipitation Sensor

##### GMX603 Rain Gauge

The GMX603 is designed as a low-maintenance liquid precipitation sensor. The solid-state optical design eliminates moving parts, reducing wear and maintenance requirements compared to traditional tipping bucket rain gauges. However, periodic maintenance is still necessary to ensure optimal performance and accuracy.

Maintenance requirements will vary depending on the installation environment. Sites with high levels of dust, sand, pollen, or airborne debris may require more frequent cleaning.

Under normal conditions, the optical surfaces should be cleaned annually. In dusty or high-pollution environments, more frequent cleaning may be necessary.

To clean the optical surfaces:

- Use a soft, lint-free cloth to gently wipe the optical windows
- If necessary, slightly dampen the cloth with clean water or a non-aggressive optical cleaning solution
- Never use abrasive materials, solvents, or harsh chemicals
- Verify the sensor is still properly aligned



### Precipitation Sensor

GMX240, 400, 551, 600 Solid State Rain Gauge

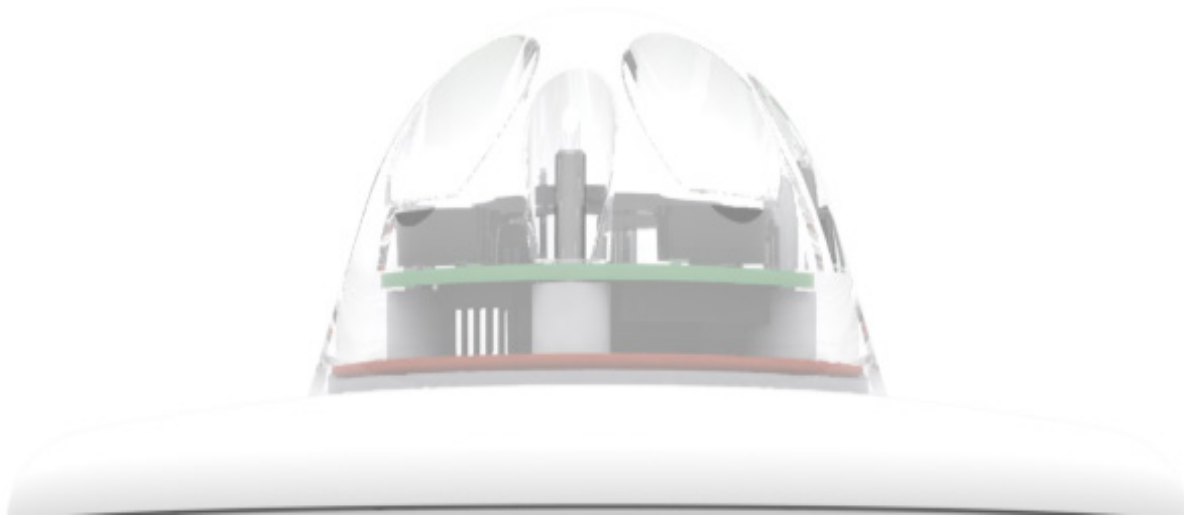

Users/distributors should clean the plastic dome with a soft, lint free cloth and where necessary with a non-aggressive cleaning solution ideally once a week. Where this is not possible, cleaning should be done during regularly scheduled visits to the sensor and site. It is recommended that the rain gauge sensor should be cleaned every 3 months as a minimum.

Users can check operation of the rain gauge by performing a simple test of functionality by spraying some water using a mist nozzle similar to that used in many households for watering plants. The MaxiMet rain gauge should register incremental rain fall when sprayed with water.

### GMX 551 Kalyx Tipping Bucket Rain Gauge (similar checks should be carried out on other tipping bucket rain gauges)

Maintenance periods are site dependant, but periodic maintenance every 2-3 months should be considered. To ensure reliable and accurate measurements, we recommend that the following checks are carried out at each visit to the rain gauge.



If the gauge is still connected to a data logger and logger is operating, care must be taken to avoid tipping the bucket when carrying out the following operations.

- Inspect the funnel and filter for any damage or blockage. At certain times of the year leaves may have accumulated in the funnel. Dirt and dust can also block the filter, preventing or reducing the flow rate to a slow drip to the bucket beneath. The leaves can easily be removed from the funnel.
- Unscrew the 3 nylon screws securing the funnel to the case assembly and remove the funnel.
- Remove the end cap from the filter tube; remove the gauze filter material carefully.

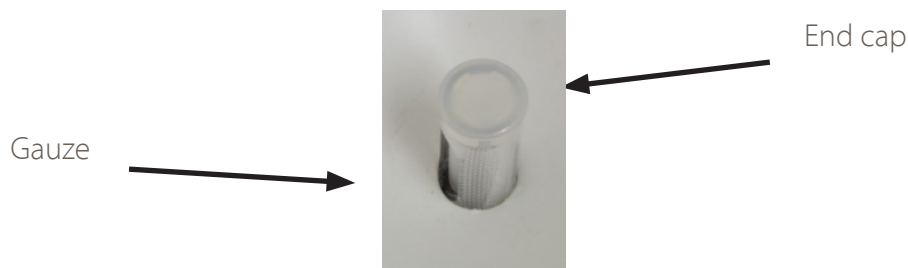

- The external plastic funnel surface should be cleaned with clean water and a sponge; this will generally remove any mildew should this have been allowed to grow.

Chemicals/detergents should not be used if the water is to be collected for later analysis. Otherwise, mild detergents can be used if required.

The internal funnel tube that directs water to the tipping buckets may need cleaning. Use a pipe cleaner or small nylon bristle wire brush or similar part to insert into the pipe to clean it.

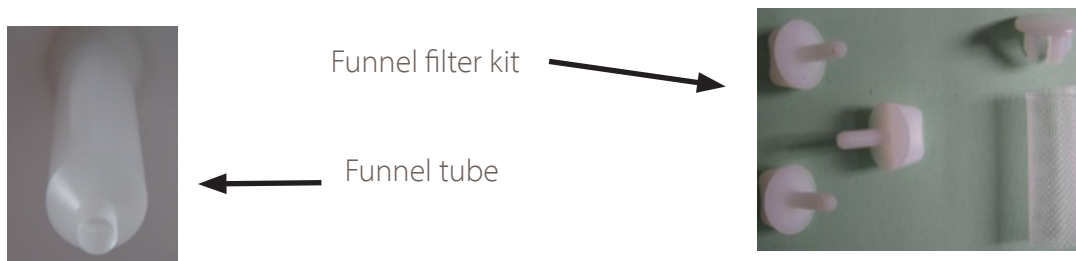

- Clean or replace the gauze filter into the filter tube and replace the top cap (for spares contact Gill Instruments).

## Compact Weather Station

- Remove and clean any dirt from the tipping bucket, being careful not to tip the bucket should the rain gauge still be logging

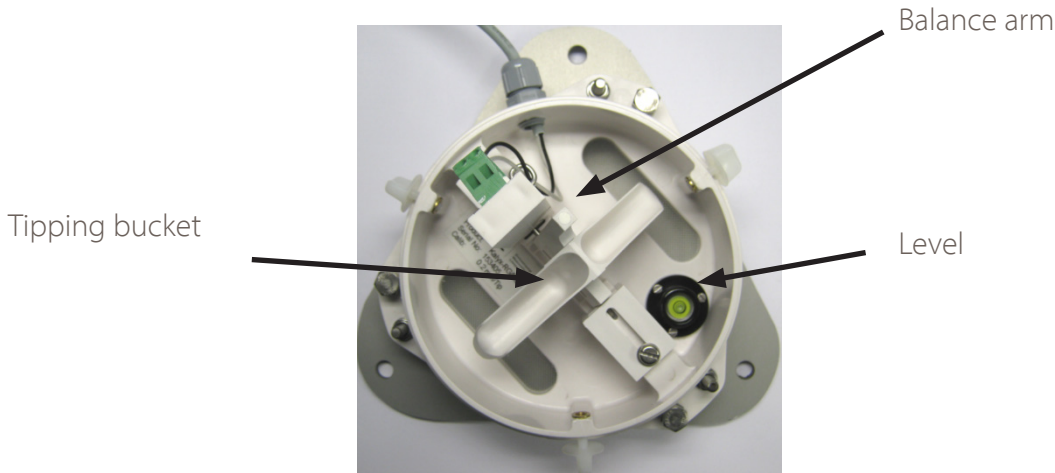

Check that the gauge is still level. It is possible for the gauge to become tilted as a result of small ground movements, vandalism etc.

There will be times when, for one reason or another, the rain gauge will be not logging or will be disconnected from the logger. During these times it is a good idea to check the balance arm of the bucket for stiffness. The easiest way to do this in the field is to try and balance the bucket in its centre position. It should be very difficult if not impossible to achieve this. If the bucket balances easily then examine the bucket closely for any dirt or wear on the pivot pin and bucket tubes. Any wear will require the unit to be repaired/ replaced.

There are two drain slots at the base of the instrument with a gauze covering that might require periodic cleaning. Carefully lift out the tipping bucket assembly to gain access to the drain slots for checking/cleaning.

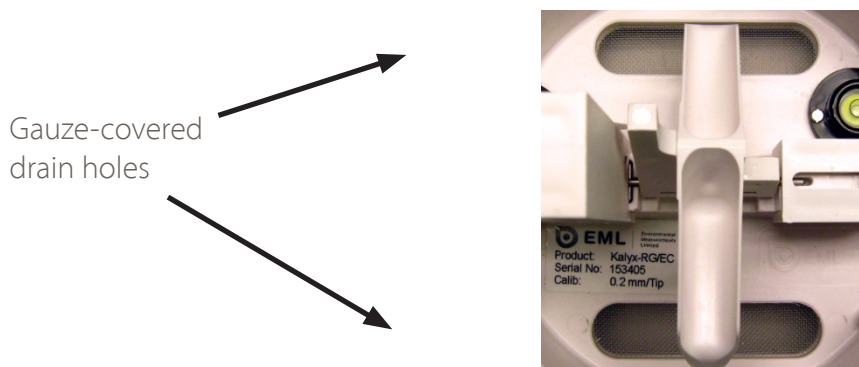

Carefully re-assemble the rain gauge parts. When reattaching the funnel to the base assembly check that the internal funnel does not foul onto the tipping bucket. This can be checked by pouring in water and checking if the bucket tips or, if the whole assembly is not fixed in position, by gently rocking the bucket and listening for the bucket to tip.

Internal parts require no lubrication.

## Compact Weather Station



MaxiMet GMX550/551 is supplied without a rain gauge. The Kalyx calibration figure (0.2mm) can be seen on the label inside the rain gauge on the underneath of the bucket and adjacent to the tip assembly.

### Spare Parts for GMX551 Kalyx Rain Gauge

Contact Gill Instruments

Kalyx Aerodynamic Rain Gauge (Gill Part No. 1957-PK-070).

Kalyx Rain Gauge spares comprising of:

- 3 off nylon screws to retain the bucket to the base assembly.
- 2 off funnel gauze filters.
- 2 off funnel gauze retainer top caps.

### Solar Sensor



Users/distributors should clean the glass dome with a soft, lint free cloth and where necessary with a non-aggressive cleaning solution ideally once a week. Where this is not possible, cleaning should be done during regularly-scheduled visits to the sensor and site. It is recommended the solar sensor should be cleaned every month as a minimum.

In order to retain compliance with ISO 9060 it is recommended that the solar MaxiMet unit is returned for calibration every 12 months. In general, solar calibration should be checked every 24 months as a minimum.

### Compass/GPS Modules

The compass and GPS module devices are maintenance-free. If required, return the MaxiMet to Gill Instruments to check the compass and GPS operation.

### Wind Sensor (WindSonic)

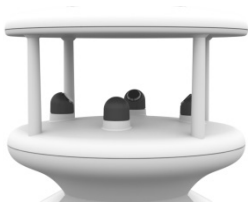

If there is any build-up of deposits on the unit, it should be gently cleaned with a cloth, moistened with soft detergent. Solvents should not be used, and care should be taken to avoid scratching any surfaces. The unit must be allowed to defrost naturally after being exposed to snow or icy conditions, DO NOT attempt to remove ice or snow with a tool.

There are no moving parts or user-serviceable parts requiring routine maintenance. Opening the unit or breaking the security seal will void the warranty and the calibration.

### Barometer

The barometer device is located internally and is not maintainable or replaceable by a user. Consideration should be given to checking the Pressure readings against a standard every 12 months. If required, return the MaxiMet to Gill Instruments to check the barometer calibration.

## Compact Weather Station

### Black Globe Cleaning

Ideally the user should try to keep black globe clean and free of biological growth. A soft, lint-free cloth and water should be used to wipe the surface. Solvents should not be used, and care should be taken to avoid scratching the paint.

The unit must be allowed to defrost naturally after being exposed to snow or icy conditions, **DO NOT** attempt to remove ice or snow with a tool.

### Spare Parts for the GMX552

The black globe sensor is user maintainable. The following spare parts are available from Gill instruments:

- Replacement black globe, locking screw and seal (Gill Part No. 5437-PK-059).
- Replacement temperature sensor for black globe (Gill Part No. 5437-PK-060).



### Removing the Black Globe

1. Unscrew the locking screw (min 3 turns) using a 2.5mm AF HEX KEY.
2. Unscrew the black globe anti-clockwise and carefully lift off vertically.

### Replacing the Temperature Sensor

With the black globe removed.

1. Remove the old temperature sensor by gripping the sensor's outer sleeve between finger and thumb, pull vertically up.
2. Hold the outer sleeve of the new temperature sensor and locate the connector end into the socket.
3. Align the white marked orientation grooves and push sensor into socket.

### Fitting the Black Globe

1. Check the O-ring for damage, replace if necessary.
2. Ensure that the O-ring is located at the bottom of the M14 thread.
3. Carefully slide the black globe over the temperature sensor and lower onto the M14 mounting thread.
4. Rotate the globe clockwise to screw into place.
5. Ensure that the sealing washer is fitted and fasten the locking screw, torque to 1Nm  $\pm$ 0.1Nm.

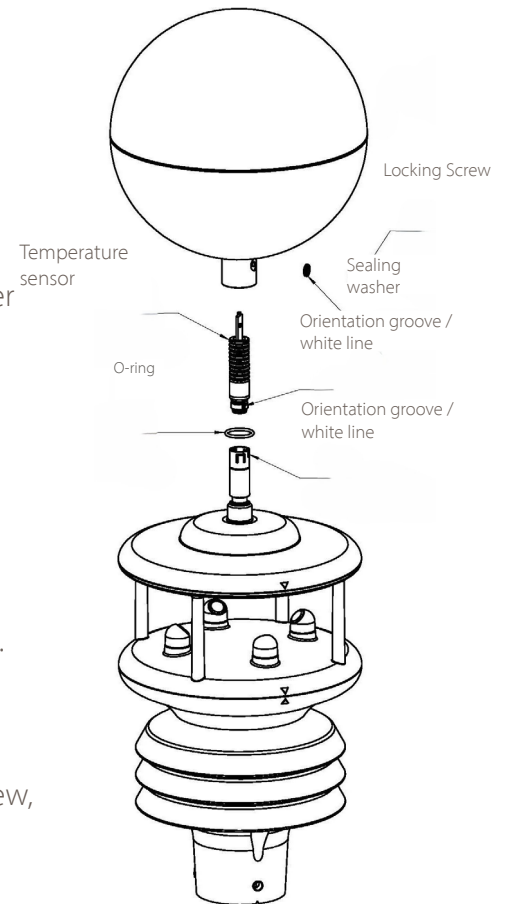

### Wet Bulb Temperature Sensor (5437-PK-046 and 5437-PK-047)

To ensure measurement accuracy, it is critical that the cotton wick remains saturated and clean. If the wick is damaged or heavily soiled, it is recommended that the wick is replaced with a fresh part.

The water bottle should be regularly refilled to ensure that the wick is partially or wholly covered in **distilled water**. Typical refill/maintenance cycles are between 2-weeks and 2-months depending on the ambient conditions and volume of water bottle used.



The GMX552 and Wet Bulb Temperature sensors do not have an alarm/alert to inform when the wick has dried out and the water bottle needs refilling. However, if the user notices that the reported wet bulb temperature (WWBT) matches or exceeds the ambient temperature reported, this could indicate that maintenance is required.



Gill recommends that the PT100 temperature sensor deployed in the Wet Bulb Temperature sensor is calibrated every 12 months to preserve accuracy. Please contact Gill Instruments or a local distributor to discuss options for calibrating in our UKAS accredited facility.

### Spare Parts for the Wet Bulb Temperature Sensor

The wet bulb temperature sensor is user maintainable. The following spare parts are available from Gill instruments:

- Wet bulb sunshade (Gill Part No. 5437-PK-048).
- Replacement PT100 temperature sensor for wet bulb sensor (Gill Part No. 5437-PK-054).
- Replacement 0.5L bottle and retainer for wet bulb sensor (Gill Part No. 5437-PK-055).
- Replacement 1.0L bottle and retainer for wet bulb sensor (Gill Part No. 5437-PK-056).
- Replacement wick and O-ring for 0.5L wet bulb sensor (5-pack) (Gill Part No. 5437-PK-057).
- Replacement wick and O-ring for 1.0L wet bulb sensor (5-pack) (Gill Part No. 5437-PK-058).

### Removing and Refitting the Water Bottle

#### To remove the bottle:

1. Push bottle retainer to one side and support bottle as it will drop down.

#### To re-fit the bottle:

1. Feed the wick into the bottle neck, ensuring it is not kinked or trapped.
2. Push bottle into the socket within the top radiation shade.
3. Pull bottle retainer over the bottle base to its centre.

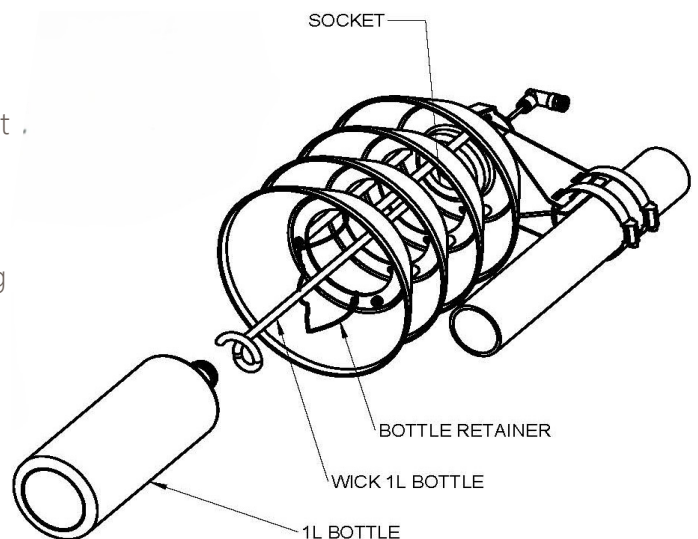

### Fitting the Optional Sunshade (5437-PK-048)

1. Remove PT100 probe (see below).
2. Place the sunshade onto the temperature sensor bracket.
3. Use the two M4 Pozi Pan screws provided to secure the sunshade to the bracket, tightening to 0.4Nm.
4. Re-fit PT100, carefully seating through the hole in the sunshade.

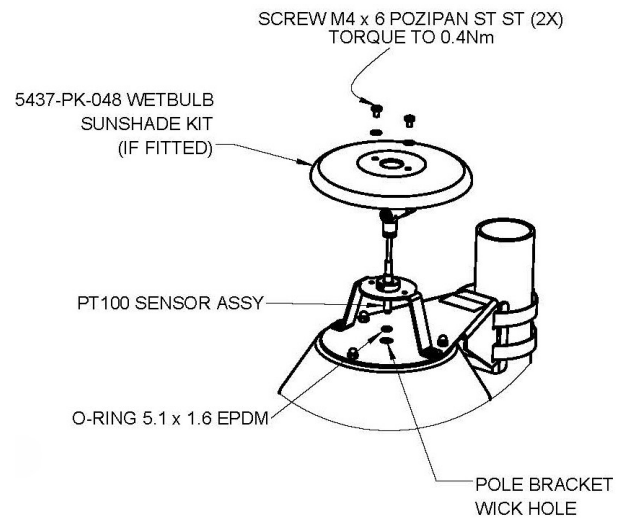

### Replacing the Wick

#### To remove the wick:

1. Unscrew the sunshade (if fitted), and lift away from mounting bracket to allow access to wick.
2. Slide the O-ring and wick down and off of the temperature sensor.
3. Remove the bottle to free the wick from the assembly.

#### To replace the wick:

1. Thread the wick through the hole in the top of the pole bracket.
2. Thread the O-ring onto the wick.
3. Slide the wick and O-ring over the temperature sensor, ensuring that the sensor is covered by the wick and meets the underside of the pole bracket. The O-ring should sit as high as possible.
4. Re-fit the sunshade (if used)
5. Fill and fit water bottle (see above)

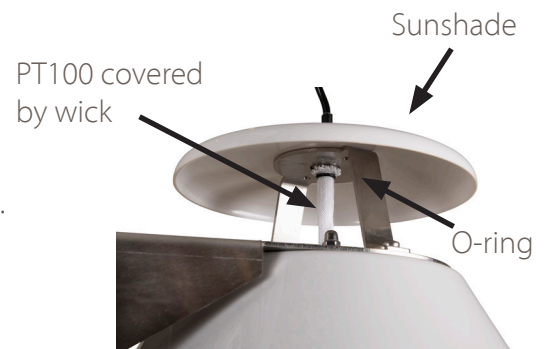

### Replacing the PT100 Temperature Probe

#### To remove the PT100

1. Ensure that the wet bulb temperature sensor is disconnected from the MaxiMet GMX552 (or alternative logging setup).
2. Unscrew the sunshade (if fitted), and lift away from mounting bracket to allow access to wick and probe.
3. Slide the O-ring and wick down and off of the temperature sensor.
4. Carefully pull the PT100 through the hole in the bracket to free it from the assembly.

#### To replace the PT100

1. Insert the PT100 through the hole in the upper bracket section (and through the sunshade if used).
2. Ensure that the wick and O-ring are in good condition and that the O-ring is fitted over the wick.
3. Slide the wick and O-ring over the temperature sensor, ensuring that the sensor is covered by the wick and meets the underside of the pole bracket. The O-ring should sit as high as possible.
4. Re-fit the sunshade (if used)
5. Connect the PT100 temperature probe to the MaxiMet (or user selected alternative logging system) using the pre-fitted M8 connector.

### UV Shield (MetSpec)



Ideally the user should try to keep MaxiMet radiation screens clean and free of biological growth but a simple wipe with some non-aggressive soft detergent cleaner will suffice. Solvents should not be used, and care should be taken to avoid scratching any surfaces. The unit must be allowed to defrost naturally after being exposed to snow or icy conditions, **DO NOT** attempt to remove ice or snow with a tool.

### Temperature, Humidity and Dewpoint

The internal temperature and humidity sensor is not user maintainable. If used in areas of high pollution or marine environments, then consideration should be given to returning the unit for maintenance at Gill instruments or your nearest distributor, if available. Gill recommends carrying out this service every 12 to 24 months to ensure proper performance.

### GMX550/GMX551/GMX552 Side Connector



If there is no external rain gauge or Wet Bulb Temperature Sensor connected to the MaxiMet side connector, cover the connector with the cap provided with the MaxiMet to prevent dirt and dust from entering. On the GMX551 there is +12V dc across the side connector pins, take care not to short out the pins.

### Calibration

A calibration check can be done by any user/distributor by comparing the values measured by MaxiMet with a reference value or in an environmental chamber. Users should understand that these checks are not the same as the calibration checks or calibration done at Gill, but they can provide users with some degree of confidence to the validity of their measurements. If a user/distributor notices a significant difference between the MaxiMet and their test environment/reference they should contact Gill to discuss this and see if a calibration is required. See individual parts above for any recommended calibration periods.

### Fault-finding

Symptom	Solution
No output.	<p>Check DC power to MaxiMet, cable and connections.            Check communications settings of the MaxiMet and host system match, including correct COM port.            Check that the unit is in continuous mode.            Check that in-line communication devices are wired correctly.</p> <p> It is usual for anemometer TX + to be connected to converter device RX +. If appropriate use Safe Mode to attempt to obtain communication with the MaxiMet.</p>
Corrupted output.	<p>Check that the communication settings of the MaxiMet and host system match.            Try a slower baud rate.            Check cable lengths and type of cable.            Check for sources of external signal interference.</p>
One-way communication.	<p>Check that the wiring is in accordance with the manual.</p>
Unexpected Temperature /Dewpoint readings.	<p>Check that the Temperature and Dewpoint units of measure (C, F, K) settings are correct on power up.</p>
Unexpected Wind readings.	<p>Check that the Wind Sensor units of measure (m/s, knots, kph, ft/min, mph) settings are correct on power up.</p>
Unexpected Temperature/Dewpoint and Humidity readings.	<p>Temperature and Humidity Device potentially faulty.</p>
Unexpected Barometer Readings.	<p>Check units of measure are set correctly and if offset HASTN or HASL readings have been applied.</p>
Unexpected Rainfall readings or no readings when raining.	<p>Check in the case of the solid state sensor that the sensor is not obstructed. In the case of a tipping bucket rain gauge, check that the funnel and filter are not clogged and are clean. Check that the tipping bucket mechanism swings freely. In the case of another user-supplied external rain gauge, check that the rain gauge is functioning correctly.</p>
Unexpected wet bulb globe temperature/wet bulb/black globe readings.	<p>Ensure that the MaxiMet and Wet Bulb Sensors are placed in a suitable position, unshaded and unsheltered by nearby constructions and placed at a height representative of the working conditons of the environment to be monitored.</p> <p>Check in the case of the external wet bulb sensor that the sensor is connected correctly. Check that the reservoir has sufficient distilled water and that the cotton wick is saturated, clean and extends over the PT100 probe. Similar checks should be carried out in the case of another user-supplied wet bulb temperature sensor.</p> <p>Check that no damage has occurred to the black globe sensor and that the globe remains clean and free of detritus.</p>
Status code not 0000 or A.	<p>See following tables.</p>

### Sensor Status Codes

These codes are in hexadecimal.

Code	Status	Condition
0000	OK.	No fault conditions detected in measurement period.
0001	Wind measurement fault.	Wind Sensor faulty. Refer to Wind Sensor Status Codes below.
0002	GPS error.	E.g. Locating Satellite fix.
0004	Source for Corrected Wind Direction is GPS.	GPS notification.
0006	GPS Location missing.	GPS error.
0008	Tilt measurement fault.	Tilt error.
0010	Temperature measurement fault.	Temperature sensor faulty.
0020	Dewpoint fault.	If Temperature and Humidity are reporting correctly then this code indicates a main PCB fault.
0040	Humidity fault.	Humidity sensor faulty.
0080	Pressure sensor warning.	Pressure sensor reading not available/unit faulty.
0100	Compass fault.	Invalid heading due to compass fault.
0200	RTC Fault	Real-time clock faulty
0400	Black globe fault	Black globe temperature sensor faulty
8000	Heating Error	A problem with heating has been detected.
XXXX	More than one fault	Fault condition that can be the sum of any of the above eg 11 would mean that both the Wind Sensor (0001) and Temperature (0010) were faulty.

**Wind Status Codes**

These codes are in hexadecimal.

Code	Status	Condition
0000	OK.	No fault conditions detected in measurement period.
0001	Wind sensor - axis failed.	Wind axis U blocked or faulty.
0002	Wind sensor - axis failed.	Wind axis V blocked or faulty.
0004	Wind sensor - both axes failed.	Wind axes U and V blocked or faulty.
0008	Wind Sensor NVM Failure	Non-Volatile Memory checksum failed; data could be uncalibrated
0009	Wind Sensor ROM Failure	Read Only Memory checksum failed, data could be uncalibrated
000B	Wind sensor readings failed.	Wind sensor data output fault.
0100	Wind Average building.	WMO wind average building.
0200	Corrected Wind measurement not available.	Compass corrected wind measurement failure.
A	NMEA acceptable data.	No fault conditions detected in measurement period
V	NMEA void data.	Fault condition detected in measurement period.

**Heater Status Code**

These codes are in hexadecimal.

HEATSTAT must be set as a parameter for this information to be output.

Code	Status	Condition
0000	Heating Off	Indicates heating is not on
0001	Heating On	Indicates heating is on
0002	Heating Inhibited	Indicates heating is prevented from coming on
0004	Heating Current Detected	Indicates current is flowing in the heater circuit
0008	Power Up Test Timer	Indicates heating is on for a short period after power on
0010	Supply Low During Surge Period	Indicates the supply voltage has dropped below the minimum as a result of the heating being on.
0020	No Current Detected	Indicates no current detected when heating was turned on.
0040	Heating Supply Too High	Voltage is too high for heating
0080	Heating Supply Too Low	Voltage is too low for heating
0100	Ambient Temperature Invalid	Replace humidity/temperature sensor

### Safe Mode

If the unit will not communicate, or the communication protocol settings are not known, then Safe Mode can be used to establish communication with the MaxiMet and change configuration settings. Details of how to use Safe Mode can be found in Appendix H on page 140.

### Major Repairs

If the unit is more seriously damaged it can be returned for repair via a local distributor or directly to Gill Instruments.

The unit should be carefully packed in the original packaging or similar packaging to avoid any further damage. Where possible, a full description of the fault, and a list of any fault codes seen, should be included. Contact details to return a unit to Gill Instruments can be found at [gillinstruments.com](http://gillinstruments.com).

### Warranty Repairs

If the unit experiences issues during the warranty period, the unit should be returned to Gill Instruments together with a copy of the original invoice.

The unit should be carefully packed in the original packaging or similar packaging to avoid any further damage. Where possible, a description of the fault, and a list of any fault codes seen, should be included.

**Instructions on how to return a unit to Gill Instruments can be found at [gillinstruments.com](http://gillinstruments.com).**

### Returning Units

If the unit must be returned, it should be carefully packed in the original packaging and returned to your authorised Gill distributor, with a full description of the fault condition. An RMA number should be obtained from Gill Instruments first if returning directly to Gill Instruments.

### Appendix N. MaxiMet Output Parameters selectable using MetSet Software



These are not presented in order of output. See 2.1 on page 7 and 2.2 on page 8 for applicability, and Appendix D on page 91 for MetSet set up.

#### **NODE - Node Letter**

MaxiMet identifying Node letter at beginning of the data string.  
Result e.g. Q (default).

#### **SPEED -Wind Speed**

Wind Speed measurement.  
Result e.g. 001.05 (metres/second default).

#### **CSPEED -Corrected Speed**

Corrected Wind Speed shall be computed as the True Wind Speed (i.e.: using GPS Speed, GPS Heading and Compass Heading) when all three of GPS Speed, GPS Heading and Compass Heading are available.

Result e.g. 003.17 (metres/second default).

Corrected Wind Speed shall not be computed when anyone (or more) of GPS Speed, GPS Heading and Compass Heading are unavailable.

Corrected Wind Speed shall not be computed when Compass Heading is unavailable.

The Gill Algorithm for generating Corrected Speed based on Compass heading is as follows: -

1. Convert Magnitude and Direction to UV.
2. Calculate applied wind in UV due to movement from GPS.
3. Calculate Corrected UV as difference between Relative and GPS wind.
4. Convert UV back to Magnitude and Direction.

#### **GSPEED (WMO) - Gust Speed**

Outputs WMO Gust Speed.

Maximum Gust Magnitude shall be computed over a block of  $m$  gust magnitudes as follows:

$$rwa\_max\_gust\_mag = \max \{gust\_mag_1, gust\_mag_2 \dots gust\_mag_m\}$$

where:

$$m = rwa\_short\_len$$

$$gust\_mag = \sqrt{\bar{u}^2 + \bar{v}^2}$$

$$\bar{u} = \frac{1}{3} \sum_{n=1}^3 \bar{u}_n$$

$$\bar{v} = \frac{1}{3} \sum_{n=1}^3 \bar{v}_n$$

Result e.g. 015.15 (metres/second default).

### CGSPEED - Corrected Gust Speed

GPS corrected Gust Speed.

Result e.g. 011.05 (metres/second default).

### AVGSPEED (WMO) - Average Speed

Outputs the World Meteorological Organisation (WMO) Average Wind Speed reading based on AVG short and AVG long settings (see WMO Average Wind Reading Notes on page 98).

Result e.g. 001.45 (Metres/second default).

A short term average magnitude shall be computed every *rwa\_short\_len* samples as follows:

$$mag_{st} = \sqrt{u_{st}^2 + v_{st}^2}$$

where:

$$u_{st} = \frac{1}{N} \sum_{n=1}^N \vec{u}_n$$

$$v_{st} = \frac{1}{N} \sum_{n=1}^N \vec{v}_n$$

$\vec{u}_n$  is the  $n^{\text{th}}$  calibrated u-vector generated at P-rate

$\vec{v}_n$  is the  $n^{\text{th}}$  calibrated v-vector generated at P-rate

$N = rwa\_short\_len$

### AVGCSPEED (WMO) -Average Corrected Speed

Outputs the World Meteorological Organisation (WMO) Average Wind Speed reading based on AVG short and AVG long settings (see WMO Average Wind Reading Notes on page 98).

Result e.g. 001.45 (metres/second default).

### DIR - Direction

Wind Direction relative to the MaxiMet north marker.

Result e.g. 132 (degrees).

### CDIR - Corrected Direction

Corrected Wind Direction shall be computed as the Apparent Wind Direction (i.e.: using Compass Heading) when Compass Heading is available but anyone (or more) of GPS Speed and GPS Heading are unavailable.

Corrected Wind Direction shall be computed as the True Wind Direction (i.e.: using GPS Speed, GPS Heading and Compass Heading) when all three of GPS Speed, GPS Heading and Compass Heading are available.

Result e.g. 116 (degrees). Corrected Wind Direction shall not be computed when Compass Heading is unavailable.

The Gill Algorithm for generating Corrected Direction based on Compass heading is as follows: -

1. Convert Magnitude and Direction to UV.
2. Calculate applied wind in UV due to movement from GPS.
3. Calculate Corrected UV as difference between Relative and GPS wind.
4. Convert UV back to Magnitude and Direction.

## Compact Weather Station

### GDIR (WMO) - Gust Direction

Outputs WMO Gust Direction. Maximum Gust Direction shall be computed over a block of  $m$  vector averages as follows:

$$rwa\_max\_gust\_dir = \arctan\left(\frac{\overline{u_k}}{\overline{v_k}}\right)$$

where:

$k$  is the index of `gust_mag` selected for `rwa_max_gust_mag` defined above

$\overline{u_k}$  is the  $k^{\text{th}}$  u-vector average defined above

$\overline{v_k}$  is the  $k^{\text{th}}$  v-vector average defined above

Result e.g. 123 (degrees).

### CGDIR - Corrected Gust Direction

GPS corrected Gust Direction.

Result e.g. 135 (degrees).

### AVGDIR (WMO) - Average Direction

Outputs WMO Average Direction Wind reading based on AVG short and AVG long settings (see WMO Average Wind Reading Notes on page 98).

Result e.g. 145 (degrees).

A short-term average direction shall be computed every `rwa_short_len` samples as follows:

$$dir_{st} = \arctan\left(\frac{u_{st}}{v_{st}}\right)$$

where:

$u_{st}$  = short-term average u – vector defined above

$v_{st}$  = short-term average v – vector defined above

A long-term average direction shall be computed every `rwa_long_len` samples as follows:

$$rwa\_direction = \arctan\left(\frac{u_{lt}}{v_{lt}}\right)$$

where:

$$u_{lt} = \frac{1}{M} \sum_{n=1}^M u_{st_n}$$

$$v_{lt} = \frac{1}{M} \sum_{n=1}^M v_{st_n}$$

$u_{st_n}$  = nth short-term u-vector average defined above

$v_{st_n}$  = nth short-term v-vector average defined above

### AVGCDIR (WMO) - Average Corrected Direction

Outputs WMO average Compass Corrected Direction wind reading based on AVG short and AVG long settings (see WMO Average Wind Reading Notes on page 98).

Result e.g. 131 (degrees).

### PRESS - Pressure

Outputs the MaxiMet Pressure reading.

Result e.g. 1021.3 (hectopascals default).

### PASL Pressure at Sea Level

Outputs Barometric Pressure at Sea Level if HASL figure set (see Pressure on page 101).

$$P = P_b \left( \frac{T_b}{T_b + L_b \times (-h)} \right)^{\frac{g_0 \times M}{R \times L_b}}$$

where:

$P$  = adjusted pressure

$P_b$  = pressure (pascals) - as measured by the pressure sensor

$T_b$  = temperature (K)

$L_b$  = standard temperature lapse rate (K/m) in ISA. For the Troposphere this is assumed to be -0.0065 Kelvin/metre.

$h$  = height (meters) = sensor's height above (or below) sea level, i.e. 'Height Above Sea Level' plus 'Height Above Station'

$R$  = universal gas constant for air: 8.31432 N·m/(mol·K)

$g_0$  = gravitational acceleration (9.80665 m/s<sup>2</sup>)

$M$  = molar mass of Earth's air (0.0289644 kg/mol)

Result e.g. 1015.7 (hectopascals default).

## Compact Weather Station

### PSTN - Pressure at Station

Outputs Barometric Pressure at Station (which can be positioned anywhere) if HASTN figure set (see below and Pressure on page 101).

Pressure at station shall be computed as:

$$P = P_b \left( \frac{T_b}{T_b + L_b \times (-h)} \right)^{\frac{g_0 \times M}{R \times L_b}}$$

where:

$P$  = adjusted pressure

$P_b$  = pressure (pascals) - as measured by the pressure sensor

$T_b$  = temperature (K)

$L_b$  = standard temperature lapse rate (K/m) in ISA. For the Troposphere this is assumed to be -0.0065 Kelvin/ metre.

$h$  = height (meters) = 'Height Above Station', i.e. the difference between the sensor height above (or below) local ground level.

$R$  = universal gas constant for air: 8.31432 N·m / (mol·K)

$g_0$  = gravitational acceleration (9.80665 m/s<sup>2</sup>)

$M$  = molar mass of Earth's air (0.0289644 kg/mol)

Result e.g. 1001.2 (hectopascals default).

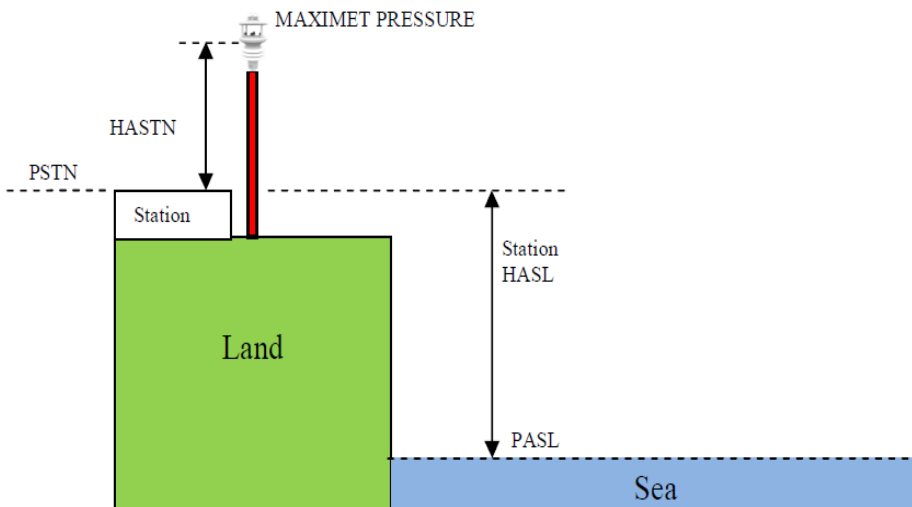

### RH - Relative Humidity

Outputs the measured Relative Humidity reading in %.

Result e.g. 028 (%).

### AH - Absolute Humidity

The humidity of the atmosphere, usually expressed as the number of grams of water contained in 1 cubic metre of air.



Relative Humidity also output, expressed as a percent, measures the current absolute humidity relative to the maximum for that temperature).

Absolute humidity shall be computed as:

$$H = \frac{C \times P_w}{T}$$

where:

$H$  is the absolute humidity

$C$  is Constant 2.16679 gK/J

$P_w$  is Vapour pressure in Pa

$T$  is Temperature in K

Result e.g. 08.14 g/m<sup>3</sup>.

### TEMP - Temperature

Outputs MaxiMet Temperature sensor readings.

Result e.g. 022.0 (°C default).

### DEWPOINT - Dewpoint

Outputs calculated Dewpoint from Temperature and Humidity readings.

$$T_d = \frac{T_n}{Y - 1}$$

where:

$$Y = \frac{m}{\log_{10} P_w / A}$$

$$P_w = \frac{P_{ws} \cdot RH}{100}$$

$T_d$  is the Dewpoint temperature

$T_n$  is the Triple point temperature (in K)

$P_{ws}$  is water vapour saturation pressure (hPa)

Result e.g. +023.1 (°C default).

### PRECIPT -Precipitation Total

Outputs Precipitation (Rain) Total reading. This is an accumulated rain reading, updated and output once per second (with default output rate setting at 1Hz).

Parameter is set to zero on MaxiMet power up and is reset to zero when the clock reads 23:59:59 to 00 (midnight) and is the default setting.

For continuous measurement, turn off auto-reset of Total Precipitation using MetSet.

Result e.g. 00000.400 (millimetres default).

### **PRECIPI - Precipitation Intensity**

Outputs Precipitation (Rain) Intensity. It is the sum of the last sixty lots of 1 minute accumulated Rain data. A new sum measurement is generated every minute.

Parameter will be set to zero on MaxiMet power up.

Result e.g. 000.200 (millimetres default).

### **PRECIPS - Precipitation Status**

Outputs Precipitation (Rain) Status as N or Y (No or Yes). Changes N to Y when total precipitation is incremented and changes Y to N when total precipitation has not incremented in the last 60 seconds.

Result e.g. N (or Y).

### **SOLARRAD - Solar Radiation figure**

Measures solar radiation over the range 0-1600 in W/m<sup>2</sup>.

Result e.g. 0243.

### **SOLARHOURS - Sunshine Hours**

Sunshine hours are computed as the period of time, in hours, within a 24 hour calendar day (i.e.: accumulated during the present day) that the measured irradiance exceeds 120 W/m<sup>2</sup>.

Sunshine hours shall be displayed with 2 integral digits and 2 decimal places.

Result e.g. 01.02 (hours).

### **WCHILL - Wind Chill**

The perceived decrease in air temperature felt by the body on exposed skin due to the flow of air.

See WMO Document TD-1184.

$$W = 13.12 + 0.6215 T_{air} - 11.37 V_{10m}^{0.16} + 0.3965 T_{air} \cdot V_{10m}^{0.16}$$

where:

$W$  is the WindChill index based on Celcius Temperature scale.

$T_{air}$  = The air temperature in Degrees Celcius.

$V_{10m}$  = the Wind speed at 10 Metres (standard anemometer height) in kilometres/hour.

Result e.g. -012 (°C default).

**Note:** Wind Chill is only reported when the temperature is below 10°C and the wind speed is at least 1.5m/s.

### HEATIDX - Heat Index

What the temperature feels like to the human body when relative humidity is combined with the air temperature (also known as apparent temperature).

**Simple Heat Index** is defined as:

$$HI_s = 0.5\{T + 61.0 + [1.2(T - 68.0)] + (0.094RH)\}$$

where:

$HI_s$  is Simple Heat Index expressed as an apparent temperature in degrees F.

$T$  is MaxiMet Temperature in degrees F.

$RH$  is MaxiMet Relative Humidity in percent.

**Rothfusz Heat Index** is defined as:

$$HI_r = -42.379 + 2.049T + 10.143RH - 0.225T.RH - 0.0068T^2 \\ - 0.0548RH^2 + 0.00123T^2RH + 0.00085T.RH^2 \\ - 0.00000199T^2RH^2$$

where:

$HI_r$  is the Rothfusz Heat Index expressed as an apparent temperature in degrees F.

$T$  is the MaxiMet Temperature in degrees F.

$RH$  is the MaxiMet Relative Humidity in percent.

See [http://www.wpc.ncep.noaa.gov/html/heatindex\\_equation.shtml](http://www.wpc.ncep.noaa.gov/html/heatindex_equation.shtml)

**Rothfusz Adjustment** is defined as follows:

If the Relative Humidity is less than 13% and the Temperature is above 80 and below 112 degrees F (above 26.66 and below 44.44 °C):

$$R_{Adj} = - \left[ \frac{(13 - RH)}{4} \right] \sqrt{\{[17 - |T - 95|]/17\}}$$

where:

$R_{Adj}$  = Rothfusz Adjustment,

$T$  = MaxiMet Temperature in degrees F,

$RH$  = MaxiMet Relative Humidity in percent,

If the Relative Humidity is greater than 85% and the Temperature is above 80 and below 87 degrees F (above 26.66 and below 30.55 °C).

$$R_{Adj} = [(RH - 85)/10]. [(87 - T)/5]$$

### HEATSTAT - Heater Status Code

See Heater Status Code on page 178 for a full description of the heater status codes.

## Compact Weather Station

If Relative Humidity and Temperature conditions are outside the two bands defined above:

$$R_{Adj} = 0$$

where:  $R_{Adj}$  = Rothfusz Adjustment

When  $HI_s \geq (HI_r + R_{Adj})$ , MaxiMet Heat Index shall be  $HI = HI_s$

where:

$HI$  = MaxiMet Heat Index expressed as an apparent temperature in degrees F,

$HI_s$  = Simple Heat Index expressed as an apparent temperature in degrees F.

When  $HI_s \leq (HI_r + R_{Adj})$ , MaxiMet Heat Index shall be  $HI = HI_r + R_{Adj}$

where

$HI$  is the MaxiMet Heat Index expressed as an apparent temperature in degrees F,

$HI_r$  is the Rothfusz Heat Index expressed as an apparent temperature in degrees F,

$R_{Adj}$  is the Rothfusz Adjustment.

Result e.g. +028 (°C default).



Heat Index is only reported when the temperature is above 75°F (approximately 23.88°C) and both Relative Humidity and Temperature are functioning.

### AIRDENS - Air Density

Outputs calculated Air Density from Pressure and Temperature readings.

$$Density = \frac{P}{R \times T}$$

where:

$P$  = measured absolute pressure in Pa

$R$  = the gas constant (287.05Jkg-1K-1)

$T$  = Temperature in K

Result e.g. 1.0 (kgm-3).

### WBTEMP - Wet Bulb Temperature (derived)

The temperature a parcel of air would have if it were cooled to saturation (100% relative humidity) by the evaporation of water into it, with the latent heat being supplied to the parcel.

Result e.g. -012.3 (°C default).

For temperatures between -20 and 50 °C and RH humidity ranges of 5 and 99%, wet bulb temperature shall be computed as:

$$T_w = T \cdot \tan^{-1}(0.1522\sqrt{RH\%} + 8.314) + \tan^{-1}(T + RH\%) \\ - \tan^{-1}(RH\% - 1.676) \\ + 0.003918(RH\%)^{3/2} \tan^{-1}(0.0231RH\%) - 4.686$$

where:

$T_w$  = wet bulb temperature in °C,

$T$  = air temperature in °C,

$RH\%$  = relative humidity.

## Compact Weather Station

Note: The calculation is based on a mean sea level pressure of 1013.25 hPa (according to the International Civil Aviation Organization).

Outside temperatures between -20 °C and 50 °C and RH humidity ranges of 5 and 99%, wet bulb temperature shall not be computed.

### WWBT - Wet Bulb Temperature (external)

Outputs the 'wet' wet bulb temperature from the external Wet Bulb Temperature Sensor (e.g. 5437-PK-046 or 5437-PK-047).

Result e.g. 016.0 (°C default).

### BGT - Black Globe Temperature

Outputs the black globe temperature, a measure of the heating effect from solar radiation.

Result e.g. 020.5 (°C default).

### WBGT - Wet Bulb Globe Temperature

Wet bulb globe temperature (WBGT) is a heat stress index which accurately reflects the level of thermal stress that the human body is subjected to. It takes into account both the heating effect of solar radiation as well as the cooling effect of evaporation of sweat.

WBGT is calculated in accordance with the method outlined in the ISO standard ISO 7243:2017 for external applications (i.e. including solar loading).

$$WBGT = 0.7T_{nw} + 0.2T_g + 0.1T_a$$

where:

$T_{nw}$  = natural wet bulb temperature in °C (WWBT).

$T_g$  = black globe temperature in °C (BGT).

$T_a$  = ambient air temperature in °C

Result e.g. 017.4 (°C default).

### WBGTD - Derived Wet Bulb Globe Temperature

The derived wet bulb globe temperature outputted using the derived wet bulb temperature (WBTEMP) instead of the measured wet bulb temperature (WWBT).

$$WBGTD = 0.7T_w + 0.2T_g + 0.1T_a$$

where:

$T_w$  = derived wet bulb temperature in °C (WBTEMP).

$T_g$  = black globe temperature in °C (BGT).

$T_a$  = ambient air temperature in °C

Result e.g. 015.2 (°C default).



Outside temperatures between -20 °C and 50 °C and RH humidity ranges of 5 and 99%, derived wet bulb globe temperature shall not be computed this is due to the limitations in the output of the derived wet bulb temperature.

### **SUNR - Sunrise**

The time instant in the morning when the upper edge of the Sun's disc is coincident with the horizon.  
Result e.g. 07:55

The installation longitude and latitude must be configured using MetSet for correct readings together with location date and time.

### **SNOON - Solar Noon Time**

Defined for a given day and a specific longitude, it is the time when the sun crosses the meridian of the observer's location. At solar noon, a shadow cast by a vertical pole will point either directly north or directly south depending on the observer's latitude and the time of year.

<http://www.esrl.noaa.gov/gmd/grad/solcalc/glossary.html>

Result e.g. 11:56.

The installation longitude and latitude must be configured using MetSet for correct readings together with location date and time.

### **SUNS - Sunset**

The time instant in the evening when the upper edge of the Sun's disc is coincident with the horizon.  
Result e.g. 15:57

The installation longitude and latitude must be configured using MetSet for correct readings together with location date and time.

### **SUNP - Position of the Sun**

A function of date, time and the geographic coordinates of the observer on the surface of the Earth. As the Earth moves around the Sun during the course of the year, the Sun appears to move with respect to the fixed stars on the celestial sphere, along a path called the "ecliptic". The Earth's rotation about its axis causes the fixed stars to move in the sky in a way that depends on the observer's geographic latitude.

[https://en.wikipedia.org/wiki/Position\\_of\\_the\\_Sun](https://en.wikipedia.org/wiki/Position_of_the_Sun), <https://en.wikipedia.org/wiki/Analemma>

Result e.g. 021:-61 (Azimuth and Elevation in degrees)

**Note:** The installation longitude and latitude must be configured using MetSet for correct readings together with location date and time.

### **TWIC - Twilight Civil**

Begins in the morning, or ends in the evening, when the geometric centre of the Sun is 6 degrees below the horizon.

**Beginning of Morning Twilight (Civil):** Defined as the instant in the morning, when the centre of the Sun is at a depression angle of six degrees ( $6^\circ$ ) below an ideal horizon. At this time in the absence of moonlight, artificial lighting or adverse atmospheric conditions, the illumination is such that large objects may be seen but no detail is discernible. The brightest stars and planets can be seen and for navigation purposes at sea, the sea horizon is clearly defined.

**End of Evening Twilight (Civil):** Defined as the instant in the evening, when the centre of the Sun is at a depression angle of six degrees ( $6^\circ$ ) below an ideal horizon. At this time in the absence of moonlight, artificial lighting or adverse atmospheric conditions, the illumination is such that large objects may be seen but no detail is discernible. The brightest stars and planets can be seen and for navigation purposes at sea, the sea horizon is clearly defined.

Result e.g. 07:10



The installation longitude and latitude must be configured using MetSet for correct readings.

### **TWIN - Twilight Nautical**

Begins in the morning, or ends in the evening, when the geometric centre of the Sun is 12 degrees below the horizon.

**Beginning of Morning Twilight (Nautical):** Defined as the instant in the morning, when the centre of the Sun is at a depression angle of twelve degrees ( $12^\circ$ ) below an ideal horizon. At this time in the absence of moonlight, artificial lighting or adverse atmospheric conditions, it is dark for normal practical purposes. For navigation purposes at sea, the sea horizon is not normally visible.

**End of Evening Twilight (Nautical):** Defined as the instant in the evening, when the centre of the Sun is at a depression angle of twelve degrees ( $12^\circ$ ) below an ideal horizon. At this time in the absence of moonlight, artificial lighting or adverse atmospheric conditions, it is dark for normal practical purposes. For navigation purposes at sea, the sea horizon is not normally visible.

Result e.g. 06:28



The installation longitude and latitude must be configured using MetSet for correct readings.

## Compact Weather Station

### **TWIA - Twilight Astronomical**

Begins in the morning, or ends in the evening, when the geometric centre of the Sun is 18 degrees below the horizon.

Beginning of Morning Twilight (Astronomical): Defined as the instant in the morning, when the centre of the Sun is at a depression angle of eighteen degrees (18°) below an ideal horizon. At this time the illumination due to scattered light from the Sun is less than that from starlight and other natural light sources in the sky.

End of Evening Twilight (Astronomical): Defined as the instant in the evening, when the centre of the Sun is at a depression angle of eighteen degrees (18°) below an ideal horizon. At this time the illumination due to scattered light from the Sun is less than that from starlight and other natural light sources in the sky.

Result e.g. 05:49



The installation longitude and latitude must be configured using MetSet for correct readings.

### **XTILT - X Tilt**

X-Tilt shall be displayed in degrees with 2 signed integral digits over the range  $\pm 89$  degrees.

With respect to the MaxiMet north marker:

+XX shall indicate that the unit is tipping towards east.

-XX shall indicate that the unit is tipping towards west.

Result e.g. +01      -01  
              +10      -10

### **YTILT - Y Tilt**

Y-Tilt shall be displayed in degrees with 2 signed integral digits over the range  $\pm 89$  degrees.

+YY shall indicate that the unit is tipping towards north.

-YY shall indicate that the unit is tipping towards south.

Result e.g.    +01    -01  
                  +10    -10

### **ZORIENT - Z Orient**

Z-Orientation shall be displayed as +1 or -1.

+1 (normal upright position (+- 90 degrees)).

-1 (inverted position (+- 90 degrees)).

Result e.g. +1            -1

### **CHECKTILT - Check Tilt**

Units with an Inclinometer have a more accurate X and Y Tilt 4 Hz output that can be configured with a PC terminal program during installation if required (see para 6.8).

**X-Tilt** shall be displayed in degrees with up to 2 integral digits and a decimal point over the range 89.9°/-89.9°.

Result e.g.

88.9	-88.9
8.9	-8.9
0.9	-0.9

**Y-Tilt** shall be displayed in degrees with up to 2 integral digits and a decimal point over the range 89.9°/-89.9°.

Result e.g.

88.9	-88.9
8.9	-8.9
0.9	-0.9

**Z-Orientation** shall be displayed as 1 (upright) or -1 (inverted).

Result e.g. 1                    -1

**Compass Heading** shall be displayed in degrees (000-359) on wind output units.

Result e.g. 001.

### **COMPASSH - Compass Heading**

North direction read out from the MaxiMet compass.

Result e.g. 139 (degrees).

### **GPSHEADING - GPS Enabled Heading**

GPS Heading shall be displayed with 3 integral digits.

Result e.g. 064 (degrees).

### **GPSSPEED - GPS Speed over Ground**

Velocity at which the MaxiMet unit with GPS is travelling over ground.

Result e.g. +000.10 (metres/second (default)).

In feet/minute setting then a reading might be 00020 (no decimal places).

## Compact Weather Station

### **GPSLOCATION - GPS Latitude, Longitude and Height**

Result e.g. +50.762956;-001.539948:+4.90.

Where: +50.762956 is latitude ( $\pm 90$  degrees north/south), positive latitude equals north.

-001.539948 is longitude ( $\pm 180$  degrees east/west), negative longitude equals west.

+4.90 is height. Using GPS means that regardless of whether a station is located on a mountain or on the coastline of a country it is possible to compare pressure readings without any further calculations as the GPS information gives the height information needed to calculate the difference in elevation to sea level and then it is possible to correct the reading for it.

If GPS lock is lost, location reverts to set value or to GMT so the current location should be set manually.

### **GPSSTATUS - Location Fix and Number of Satellites**

Result e.g. 010B.

Where: 0 is padding.

1 is GPS SPS mode fix valid (0 is fix not available).

0B is a hexadecimal representation of the number of satellites acquired, 11 satellites found. 0A would be 10 satellites etc.

### **TIME (and Date) - MaxiMet Date and Time (can be updated by GPS Option)**

Time can be set manually by the user or updated by the GPS Module (if fitted). GPS time can be automatically updated every hour (GPS default setting).

By default time will be UTC.

Result e.g. 2015-06-04T10:01:36.8.

### **VOLT - Supply Voltage**

DC Supply voltage measured at the MaxiMet.

Result e.g. +10.5 (volts).

### **STATUS - Status of MaxiMet Sensors**

Outputs the MaxiMet Sensors Status Code.

Result e.g. 0000 (see Sensor Status Codes on page 176).

### **WINDSTAT - Status of Wind Sensor in detail**

Outputs status codes relating to wind sensor data.

Result e.g. 0000 (Appendix M on page 166).

### **USERINF - User Information Field**

The User Information field shall have a maximum size of 16 characters, comprised of printable ASCII characters (to exclude "@", ",", "\*", "%" and "?").



Space character may be included.

This field allows for instance to record installation or calibration dates.

Result e.g. CAL DUE 15.08.18

### Appendix O. Guarantee, FCC & EMC

#### Guarantee

For terms of guarantee contact your supplier or refer to the Gill Instruments Terms & Conditions on the website: <https://gill.group>

#### FCC

WindSonic complies with part 15 of the FCC Rules. Operation is subject to the following two conditions: -

- (1) This device may not cause harmful interference, and
- (2) This device must accept any interference received, including interference that may cause undesired operation.

This equipment has been tested and found to comply with the limits for a Class A digital device, pursuant to part 15 of the FCC Rules. These limits are designed to provide reasonable protection against harmful interference when the equipment is operated in a commercial environment. This equipment generates, uses, and can radiate radio frequency energy and, if not installed and used in accordance with the instruction manual, may cause harmful interference to radio communications. Operation of this equipment in a residential area is likely to cause harmful interference in which case the user will be required to correct the interference at his own expense.

#### EMC

Immunity test requirements for equipment intended to be used in an industrial electromagnetic environment have been applied. These test levels are above the levels expected to be experienced in normal use due to the above recommended siting conditions, but disturbances may be expected 150 to 200kHz. If any interruption to performance is experienced due to external electromagnetic signals the product will automatically return to specification once the signals levels have diminished.