

## GMX600 Compact Weather Station

The MaxiMet range of compact weather stations is designed and manufactured by Gill Instruments. MaxiMet products use reliable, high quality instruments to provide accurate meteorological information in a wide variety of applications.

### GMX600 Features

**Temperature, humidity, pressure.** A combined instrument mounted inside three double louvered, naturally aspirated radiation shields with no moving parts. The results are high performance across each measurement over long periods of time.

**Wind.** Wind speed and direction measurements are provided via an ultrasonic sensor and the addition of an electronic compass provides apparent wind measurements. Average speed and direction together with WMO averages and gust data is also provided. Add GPS (optional) to provide true wind and other features.

**Precipitation.** An integrated optical rain gauge that automatically senses water hitting its outside surface and provides measurements based on the size and number of drops. Algorithms interpret this data and simulate the output of a tipping bucket rain gauge in a serial format. The optical rain gauge has no moving parts associated with tipping bucket gauges.



TEMP, HUMIDITY & PRESSURE	PRECIPITATION	WIND	PARAMETERS
<ul style="list-style-type: none"> <li>Air Pressure / Temperature</li> <li>Relative / Absolute humidity</li> <li>Naturally aspirated UV stable Radiation shield</li> <li>Protection against wind-blown precipitation/dust</li> </ul>	<ul style="list-style-type: none"> <li>Rainfall total</li> <li>Rainfall intensity</li> <li>Rainfall Y/N</li> <li>Emulated tipping bucket</li> <li>Integrated heater</li> <li>No moving parts</li> </ul>	<ul style="list-style-type: none"> <li>Wind speed &amp; direction</li> <li>Apparent and true wind (with GPS)</li> <li>WMO wind averages and gust</li> <li>Compass</li> </ul>	<ul style="list-style-type: none"> <li>Temperature °C / °F / °K</li> <li>Relative humidity % Rh</li> <li>Barometric pressure hPa, mbar, mm Hg, In Hg</li> <li>Absolute humidity g/m<sup>3</sup></li> <li>Precipitation mm/hr, mm/total, in/hr, in/total</li> <li>Wind speed m/s, km/hr, mph, kts, ft/min</li> <li>Wind direction °</li> <li>True/apparent wind</li> <li>Angle of Tilt</li> <li>Outputs RS232, 422, 485 (ASCII), SDI-12, NMEA, MODBUS, Analogue (option)</li> </ul>
<b>GPS (OPTION)</b> <ul style="list-style-type: none"> <li>Height above sea level m</li> <li>MSL pressure</li> </ul>			

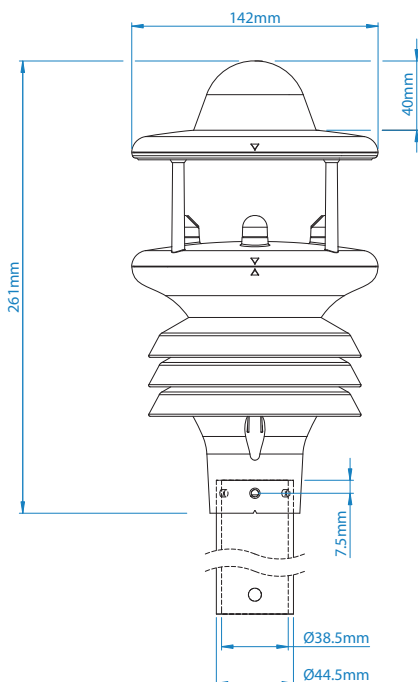

### All MaxiMet Models Feature

- Quality Measurements
- Lightweight and Robust
- Low Power Mode
- Free of Charge Software
- Gill Proven Reliability
- Compact Integrated Design
- Real Time Output
- Easy Installation
- Gill Customer Support
- 2 Year Warranty

## Applications

- Building and Industrial Controls
- Authorities
- Transport
- Coastal
- Agricultural
- Safety
- Educational
- Commercial
- Energy

WIND SPEED	
Range	0.1 m/s to 60 m/s
Accuracy	± 3% to 40 m/s, ± 5% to 60 m/s
Resolution m/s	0.01
Starting Speed	0.1 m/s
Sampling Rate	1 Hz
Units	m/s, km/hr, mph, kts, ft/min

WIND DIRECTION	
Range	0-359°
Accuracy	± 3° to 40 m/s ± 5° to 60 m/s
Resolution	1°
Sampling Rate	1 Hz
Units	Degrees

TEMPERATURE	
Range	-40°C to +70°C
Resolution	0.1
Accuracy	± 0.3°C @ 20°C
Sampling Rate	1 Hz
Units	°C, °F, °K

HUMIDITY	
Range	0-100%
Resolution	1%
Accuracy	± 2% @ 20°C (10%-90% RH)
Sampling Rate	1 Hz
Units	% Rh, g/m <sup>3</sup>

DEW POINT	
Range	-40°C to +70°C
Resolution	0.1
Accuracy	± 0.3°C @ 20°C
Units	°C, °F, °K
Sampling Rate	1 Hz

PRESSURE	
Range	300 to 1100 hpa
Resolution	0.1 hPa
Accuracy	± 0.5 hPa @ 25°C
Sampling Rate	1 Hz
Units	hPa, mbar, mmHg, inHg

PRECIPITATION	
Measurement type	Optical
Range	0 to >300 mm/hr
Precipitation Resolution	0.08 mm
Repeatability	3%
Sampling Rate	1 Hz
Units	mm/hr, mm/total, in/hr, in/total
Heating	YES

OUTPUTS	
Output rate	1/s, 1/min, 1/hr
Digital Comms Modes	Serial RS232, RS422, RS485, SDI-12, NMEA, MODBUS, ASCII
Analogue Outputs	Available via separate optional device

POWER	
Power Supply	5 to 30 Vdc
Power (Nominal) 12 Vdc	64 mA continuous high mode. 0.7 mA eco-power mode (1 hour polled)

ENVIRONMENTAL CONDITIONS	
IP Rating	66
Operational Temperature Range:	-40°C to +70°C
EMC Standard:	BS EN 61326 : 2013 FCC CFR47 parts 15.109
CE Marking	YES
RoHS compliant	YES
Weight	0.8 Kg
Origin	UK

Specifications may be subject to change without prior notice



10808 Fallstone Road  
Suite 350  
Houston, TX 77099

Tel: 281-564-5100  
admin@dynamax.com  
www.dynamax.com



1957-010 Iss5

Copyright © Gill Instruments 2017