

GMX500 Compact Weather Station

The MaxiMet range of compact weather stations is designed and manufactured by Gill Instruments. MaxiMet products use reliable, high quality instruments to provide accurate meteorological information in a wide variety of applications.

GMX500 Features

Temperature, humidity, pressure. A combined instrument mounted inside three double louvered, naturally aspirated radiation shields with no moving parts. The results are high performance across each measurement over long periods of time.

Wind. Wind speed and direction measurements are provided via an ultrasonic sensor and the addition of an electronic compass provides apparent wind measurements. Average speed and direction together with WMO averages and gust data is also provided. Add GPS (optional) to provide true wind and other features.



TEMP, HUMIDITY & PRESSURE	WIND	GPS (OPTION)	PARAMETERS
<ul style="list-style-type: none"> Air Pressure / Temperature Relative / Absolute humidity Naturally aspirated UV stable radiation shield Protection against wind-blown precipitation/dust 	<ul style="list-style-type: none"> Wind speed & direction Apparent and true wind (with GPS) WMO wind averages and gust Compass 	<ul style="list-style-type: none"> Height above sea level <i>m</i> MSL pressure 	<ul style="list-style-type: none"> Temperature °C / °F / °K Relative humidity % <i>Rh</i> Barometric pressure <i>hPa, mbar, mm Hg, In Hg</i> Absolute humidity <i>g/m³</i> Wind speed <i>m/s, km/hr, mph, kts, ft/min</i> Wind direction ° True/apparent wind Angle of Tilt Outputs <i>RS232, 422, 485 (ASCII), SDI-12, NMEA, MODBUS, Analogue (option)</i>

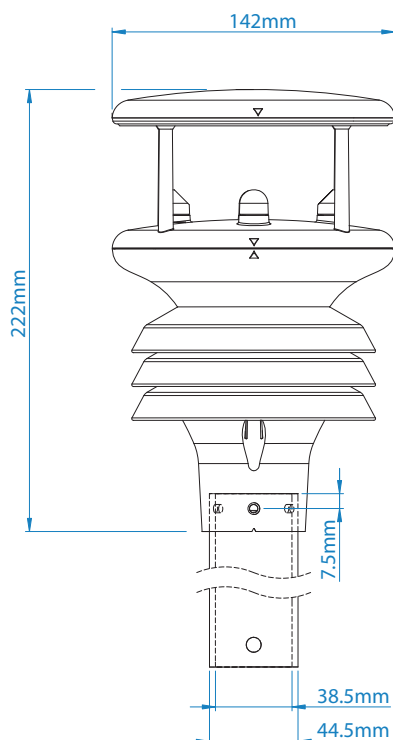

All MaxiMet Models Feature

- Quality Measurements
- Lightweight and Robust
- Low Power Mode
- Free of Charge Software
- Gill Proven Reliability
- Compact Integrated Design
- Real Time Output
- Easy Installation
- Gill Customer Support
- 2 Year Warranty

* Please see the manual for a full list of derived parameters

Applications

- Building and Industrial Controls
- Authorities
- Transport
- Coastal
- Agricultural
- Safety
- Educational
- Commercial
- Energy

WIND SPEED	
Range	0.1 m/s to 60 m/s
Accuracy	± 3% to 40 m/s, ± 5% to 60 m/s
Resolution m/s	0.01
Starting Speed	0.1 m/s
Sampling Rate	1 Hz
Units	m/s, km/hr, mph, kts, ft/min

WIND DIRECTION	
Range	0-359°
Accuracy	± 3° to 40 m/s ± 5° to 60 m/s
Resolution	1°
Sampling Rate	1 Hz
Units	Degrees

TEMPERATURE	
Range	-40°C to +70°C
Resolution	0.1
Accuracy	± 0.3°C @ 20°C
Sampling Rate	1 Hz
Units	°C, °F, °K

HUMIDITY	
Range	0-100%
Resolution	1%
Accuracy	± 2% @ 20°C (10%-90% RH)
Sampling Rate	1 Hz
Units	% Rh, g/m ³

DEW POINT	
Range	-40°C to +70°C
Resolution	0.1
Accuracy	± 0.3°C @ 20°C
Units	°C, °F, °K
Sampling Rate	1 Hz

PRESSURE	
Range	300 to 1100 hpa
Resolution	0.1 hPa
Accuracy	± 0.5 hPa @ 25°C
Sampling Rate	1 Hz
Units	hPa, mbar, mmHg, inHg

OUTPUTS	
Output rate	1/s, 1/min, 1/hr
Digital Comms Modes	Serial RS232, RS422, RS485, SDI-12, NMEA, MODBUS, ASCII
Analogue Outputs	Available via separate optional device

POWER	
Power Supply	5 to 30 Vdc
Power (Nominal) 12 Vdc	25 mA continuous high mode. 0.7 mA eco-power mode (1 hour polled)

ENVIRONMENTAL CONDITIONS	
IP Rating	66
Operational Temperature Range:	-40°C to +70°C
EMC Standard:	BS EN 61326 : 2013 FCC CFR47 parts 15.109
CE Marking	YES
RoHS compliant	YES
Weight	0.7 Kg
Origin	UK

Specifications may be subject to change without prior notice



10808 Fallstone Road
Suite 350
Houston, TX 77099

Tel: 281-564-5100
admin@dynamax.com
www.dynamax.com



1957-008 Iss 4

Copyright © Gill Instruments 2017

Gill Instruments Limited, Reg No. 2281574
Registered Office The George Business Centre, Christchurch Road, New Milton, BH25 6QJ